

K-THEORY FOR TRIANGULATED CATEGORIES I(B): HOMOLOGICAL FUNCTORS*

AMNON NEEMAN†

7. The beginning of the proof. The following theorems are true:

THEOREM 7.1. *Let \mathcal{T} be a t -category. Let \mathcal{C} be its heart. Then the inclusion*

$$\mathcal{C} \begin{array}{c} \uparrow \\ \longrightarrow \end{array} \quad \xlongequal{\quad} \quad \left(\begin{array}{c} \uparrow \\ \longrightarrow \\ \mathcal{T}_{[0,0]} \end{array} \right) \hookrightarrow \left(\begin{array}{c} \uparrow \\ \longrightarrow \\ (\mathcal{T}^b) \end{array} \right)$$

induces a homotopy equivalence.

THEOREM 4.8. *Let \mathcal{A} be an abelian category. The natural inclusion*

$$\mathcal{A} \begin{array}{c} \uparrow \\ \longrightarrow \end{array} \quad \xlongequal{\quad} \quad \left(\begin{array}{c} \uparrow \\ \longrightarrow \\ Gr_{[0,0]}(\mathcal{A}) \end{array} \right) \hookrightarrow \left(\begin{array}{c} \uparrow \\ \longrightarrow \\ Gr^b(\mathcal{A}) \end{array} \right)$$

induces a homotopy equivalence.

In this article, we will give a complete proof of Theorem 4.8. In *K-theory for triangulated categories II* we will prove Theorem 7.1, in the special case $\mathcal{T} = D^b(\mathcal{A})$ with the usual t -structure. The general proof of Theorem 7.1 will have to wait until *K-theory for triangulated categories III*. Conceptually, the general proof of Theorem 7.1 is no harder; but the details are complicated. The proof involves many more homotopies, hence we leave it for a subsequent article.

The proof given for Theorem 7.1 (in the special case) will also provide a proof for Theorem 4.8. But first we will present another, simpler proof of Theorem 4.8. The simpler proof has two virtues. Firstly, it is simpler. Secondly, all but the very last step works for Construction 4.6, and the last step pinpoints just where we need the coherent choice of differentials. This second point is important. Because most of the proof is valid for Construction 4.6, we will be able to make certain deductions about the homotopy type of that construction.

The proofs of our two theorems begin the same way. In this section we will give the common beginning. Everything in this section is valid for all four constructions.

Beginning of the Proof. Because $\mathcal{T}^b = \bigcup_{m \leq n} \mathcal{T}_{[m,n]}$, it will suffice to show that for $m' \leq m \leq n \leq n'$, the inclusion $\mathcal{T}_{[m,n]} \subset \mathcal{T}_{[m',n']}$ induces a homotopy equivalence on whichever construction we work with. Clearly, it suffices to consider two cases:

7.1.1. $m' = m - 1, n' = n;$

7.1.2. $m' = m, n' = n + 1.$

*Received April 30, 1997; accepted for publication September 20, 1997.

†Department of Mathematics, University of Virginia, Charlottesville, Virginia 22903 USA (an3r@virginia.edu).

These cases being dual, we will only consider 7.1.1. For convenience of notation, we will prove that $\mathcal{T}_{[1,n]} \subset \mathcal{T}_{[0,n]}$ induces a homotopy equivalence.

NOTATION 7.2. An arrow $\mathcal{Y} \twoheadrightarrow \mathcal{X}$ is a “monoepi”; it stands for a morphism which is at once a mono and an epi. Such a morphism is mono in degree 0, epi in degree n . There is now an obvious way to define yet more simplicial sets. The symbol

$$\boxed{\begin{array}{c} \uparrow \\ \mathcal{T}_{[0,n]} \end{array}}$$

stands, of course, for the nerve of the bicategory which is horizontally free and vertically monoepi. We can also define simplicial sets with coherent differentials, where some of the arrows are constrained to be monoepi.

Motivation for the Remainder of Section 7. Before we go on to more detail of the proof, it would perhaps be helpful to summarize briefly what we will do in the remainder of this section. The remainder of this section consists of a string of lemmas, that identify the homotopy fiber of the map

$$\boxed{\begin{array}{c} \uparrow \\ Gr_{[1,n]} \end{array}} \hookrightarrow \boxed{\begin{array}{c} \uparrow \\ Gr_{[0,n]} \end{array}}$$

More precisely, we will show that the map

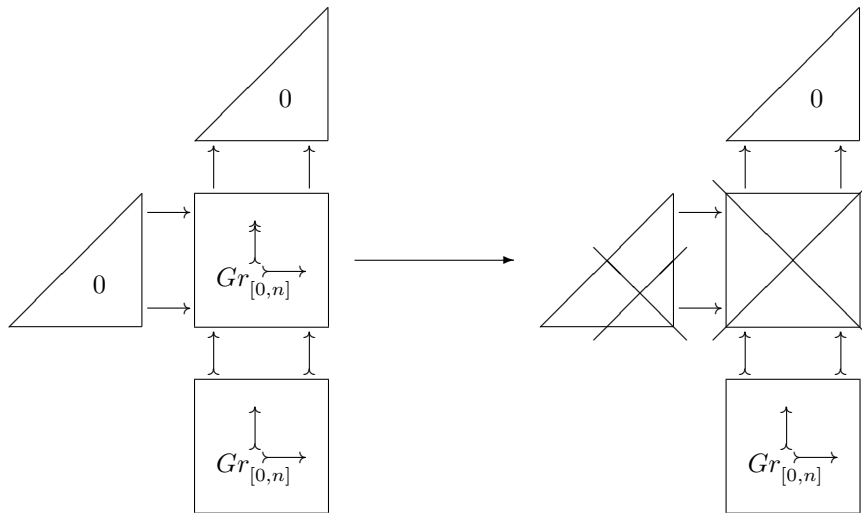

is a quasi-fibration, and the simplicial set on the left is a model for

$$\boxed{\begin{array}{c} \uparrow \\ Gr_{[1,n]} \end{array}}$$

while the simplicial set on the right is clearly a model for

$$\boxed{\begin{array}{c} \uparrow \\ Gr_{[0,n]} \rightarrow \end{array}} .$$

After all, whatever the simplicial set on the left happens to be, by the time we cross out enough to obtain the simplicial set on the right, all we are left with is

$$\boxed{\begin{array}{c} \uparrow \\ Gr_{[0,n]} \rightarrow \end{array}}$$

together with some cokernels.

This is true in both Constructions 4.6 and 4.7, i.e. with or without differentials, but only for $Gr(\mathcal{A})$. If we want a theorem about the K -theory of a triangulated category \mathcal{T} , we run into problems already at this early stage.

We will not identify the homotopy fiber of

$$\boxed{\begin{array}{c} \uparrow \\ \mathcal{T}_{[1,n]} \rightarrow \end{array}} \hookrightarrow \boxed{\begin{array}{c} \uparrow \\ \mathcal{T}_{[0,n]} \rightarrow \end{array}}$$

We will not quite succeed in proving that the map

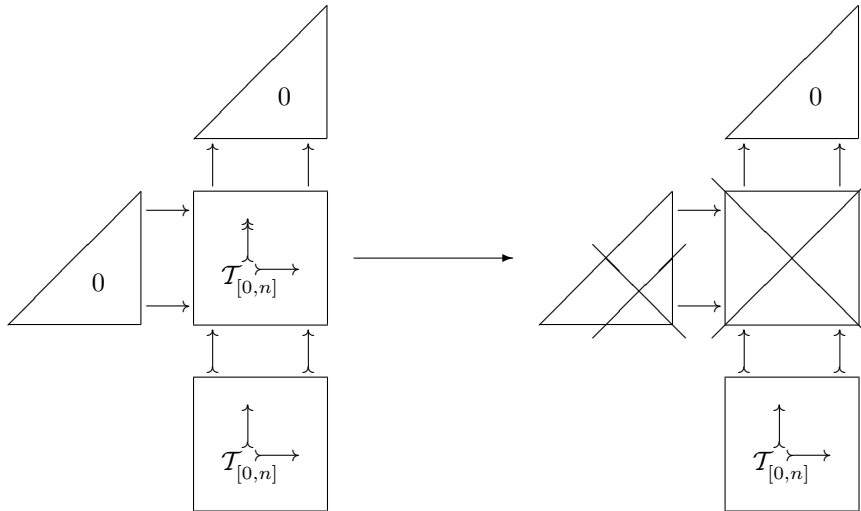

is a quasifibration (at least, in this section we will not succeed. Ultimately we will, of course, even show that the fibers are contractible.) Instead, we will show here that the fiber over the trivial simplex 0 controls the situation. The fiber over a general simplex X is the simplicial set

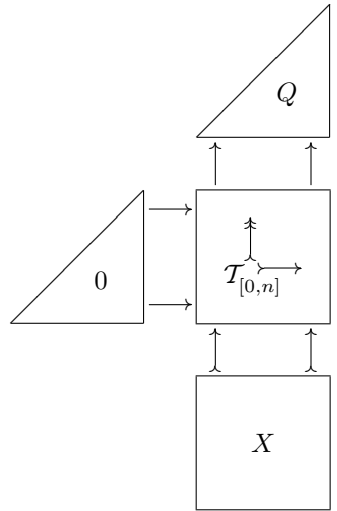

The fiber over 0 is obtained by setting the entire box labeled X to be 0; it is the simplicial set which we will denote

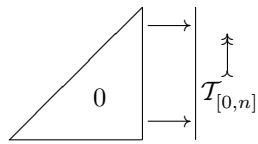

What we will show is that, if the fiber over 0 is contractible, all the other fibers must also be. Thus to prove Theorems 4.8 and 7.1, it suffices to show that the fiber over 0 is contractible.

From now on, we will begin committing the notational crime of letting \mathcal{T} stand for either a triangulated category \mathcal{T} , or $Gr(\mathcal{A})$. Thus

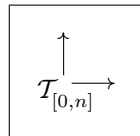

can either be the K -theory of a triangulated category, or the K -theory of $Gr(\mathcal{A})$ for some abelian category \mathcal{A} . It can, unless further specified, come either with or without coherent differentials.

End of Motivation.

We break the proof into steps.

LEMMA 7.3. *The natural inclusion*

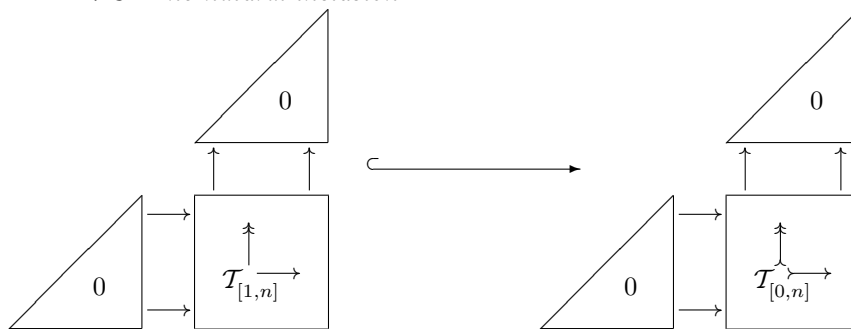

induces a homotopy equivalence.

Proof. Consider the trisimplicial set together with the two projections

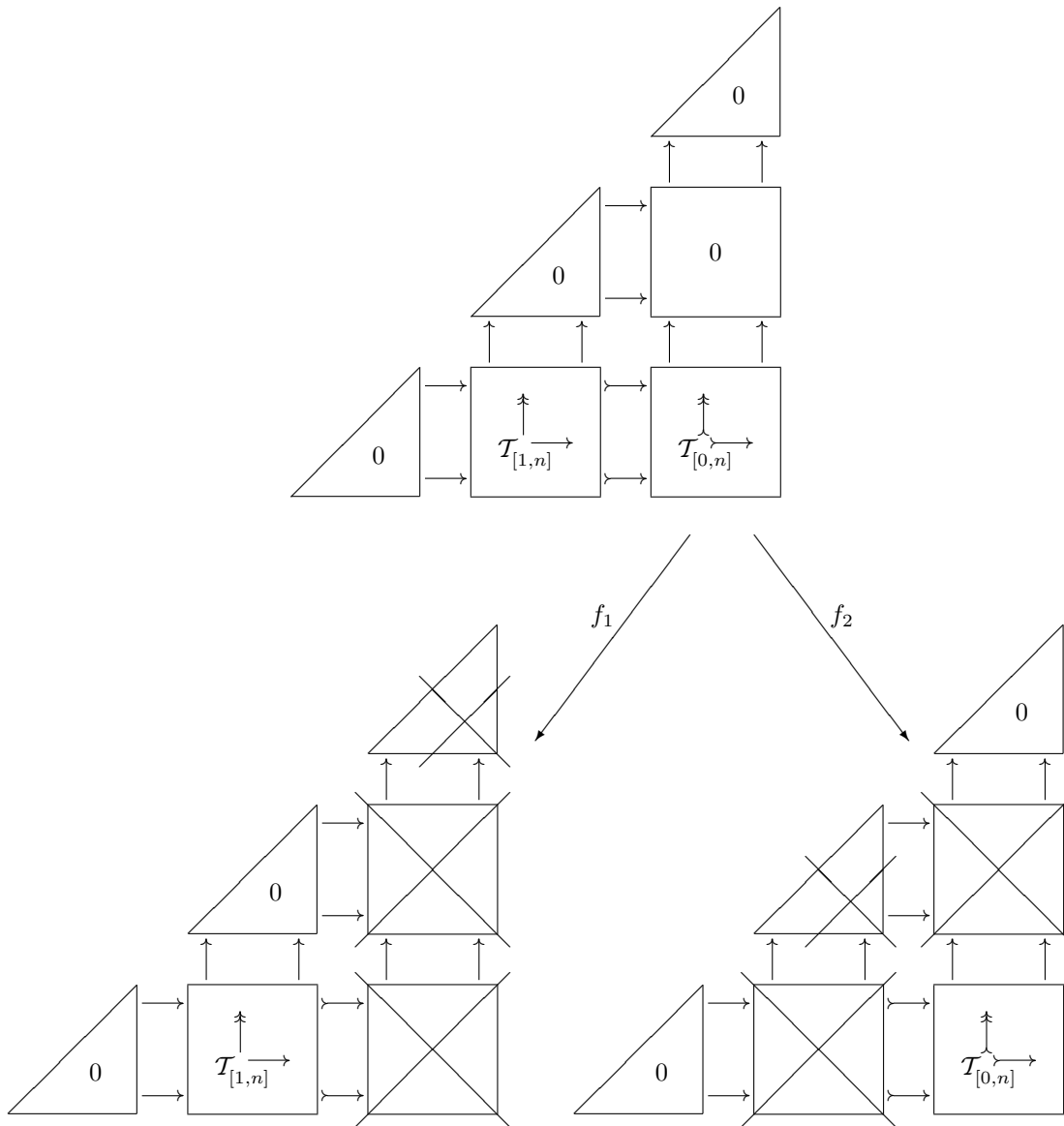

NOTATION 7.4. The simplicial set

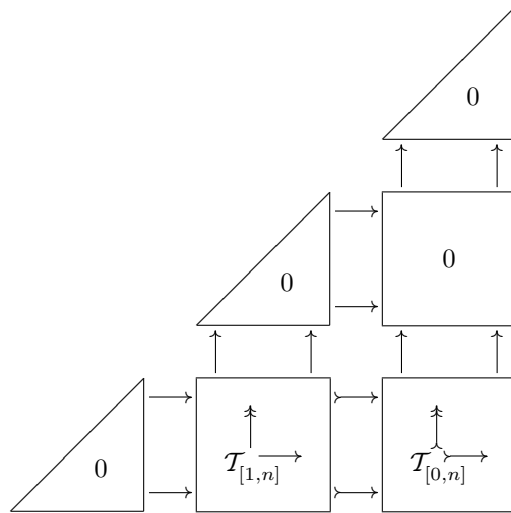

is just

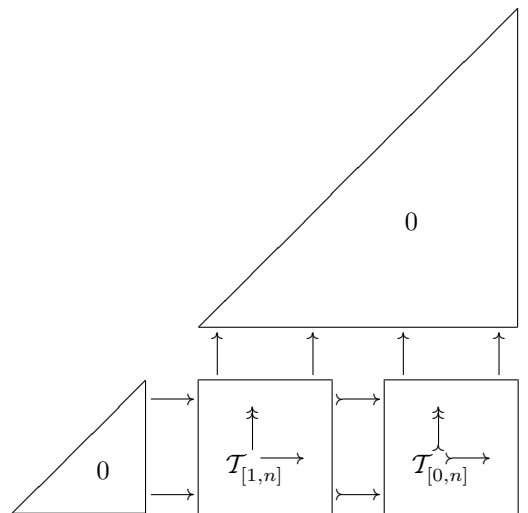

In other words, the zero inside a rectangle means simply that the restrictions on the objects and morphisms can be deduced from the surrounding data, and the author is too lazy to do it explicitly.

To prove that f_1 is a homotopy equivalence, it suffices to establish the contractibility of

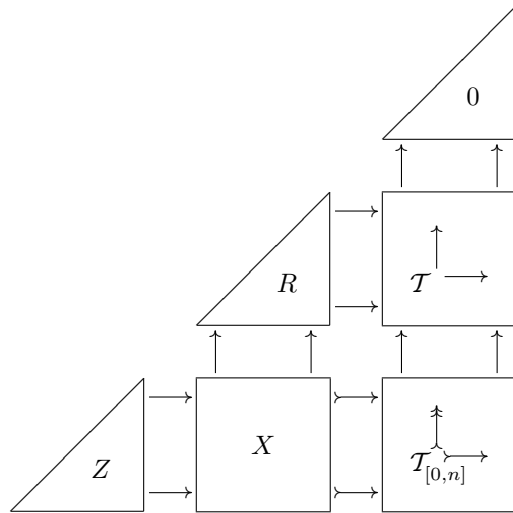

This is easily done, with the contracting homotopy

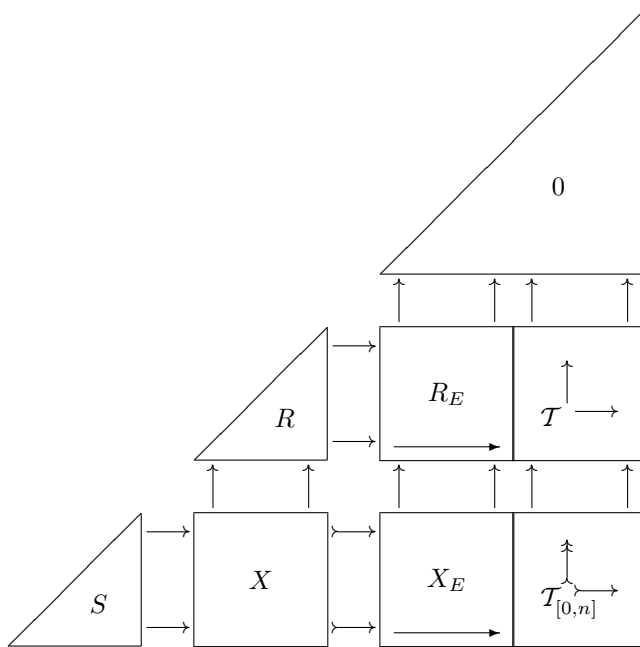

To prove that f_2 is a homotopy equivalence, it suffices to establish the contractibility of

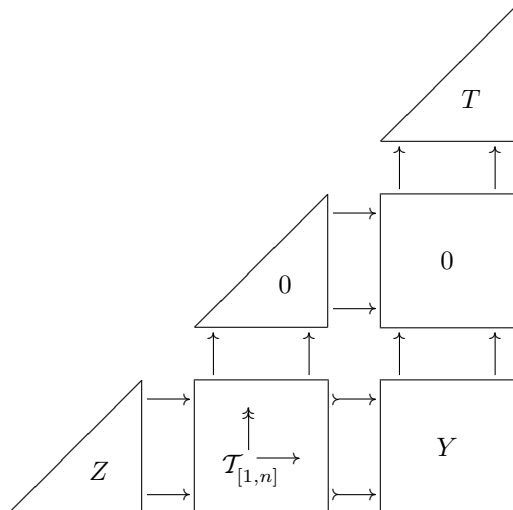

This is also easily done, with the contracting homotopy

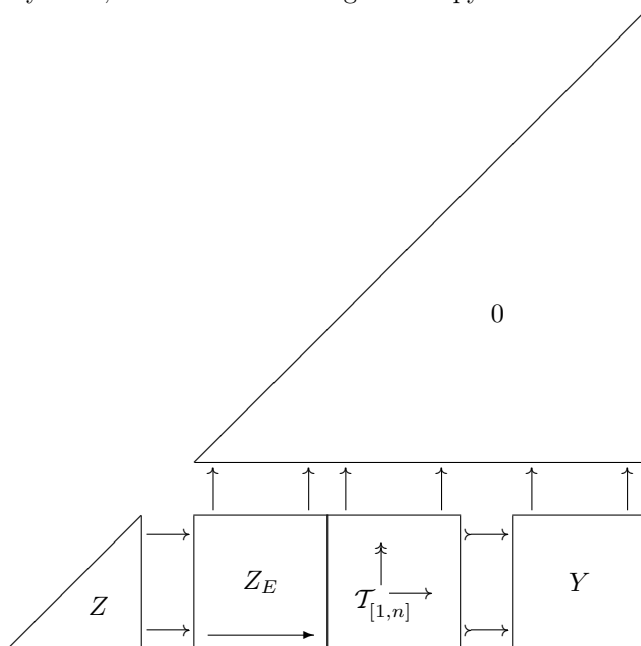

In other words, both simplicial sets are contractible by the “contraction to the initial object”. The reader should reflect a little to see that neither homotopy wanders outside its simplicial set. This is slightly tricky in the case of f_2 . The real point is that, if $Y_{ik} \twoheadrightarrow Y_{jk}$ is a monoepi in $\mathcal{T}_{[0,n]}$, and we complete it to a triangle

$$Z_{ji} \longrightarrow Y_{ik} \twoheadrightarrow Y_{jk} \longrightarrow \Sigma Z_{ji},$$

then Z_{ji} is in fact an object of $\mathcal{T}_{[1,n]}$. This follows immediately from the long exact homology sequence. \square

Strategy of the remainder of the Section. We study the projections

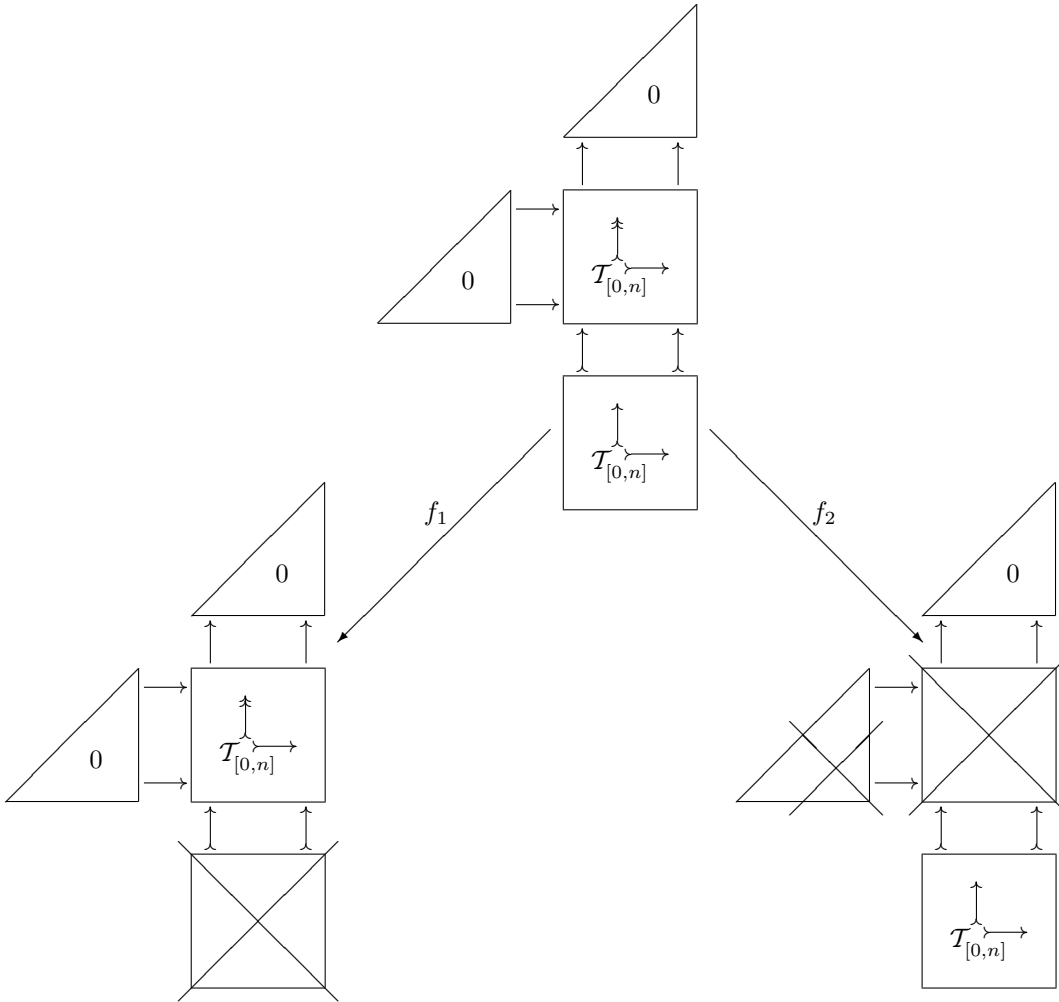

In Lemma 7.5 we will show that f_1 is a homotopy equivalence. In Lemmas 7.6, 7.11 and 7.15 we will show that f_2 is (almost) a quasi-fibration. In particular, to prove it a homotopy equivalence, it suffices to establish the fiber over 0 contractible.

End of Strategic Planning.

LEMMA 7.5. *The map f_1 above, that is*

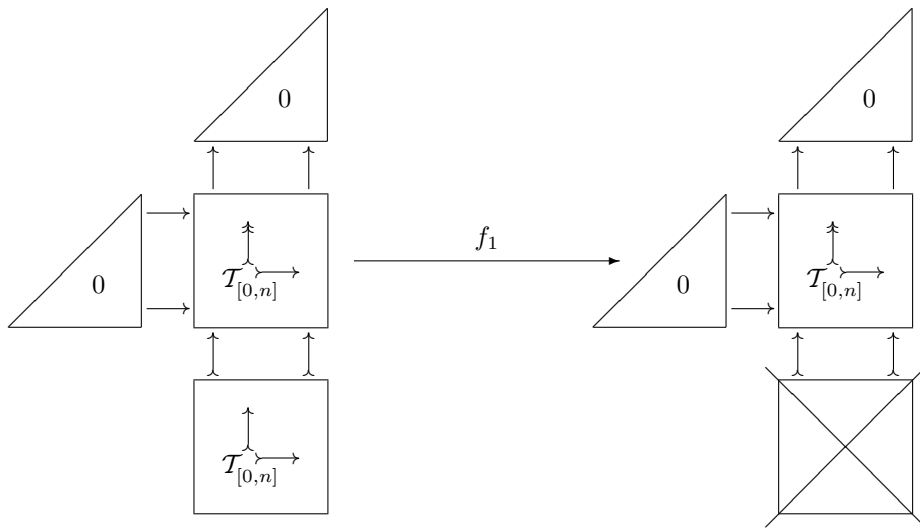

induces a homotopy equivalence.

Proof. It suffices, by Segal's theorem, to show that the fiber

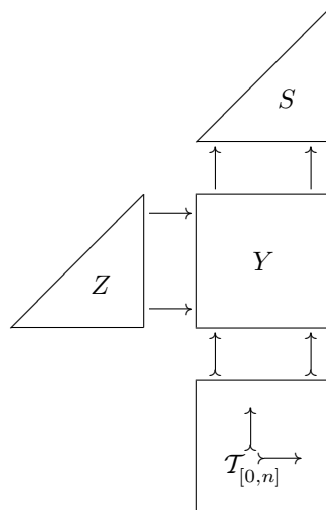

is contractible; and this is immediate from the contracting homotopy

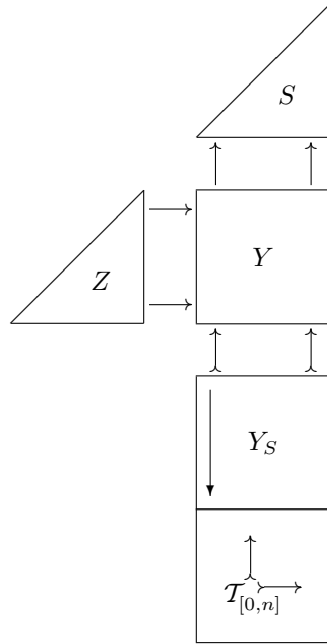

□

LEMMA 7.6. Suppose \mathcal{T} is either $D^b(\mathcal{A})$ with the standard t -structure, or $Gr^b(\mathcal{A})$. Let f_2 be the map

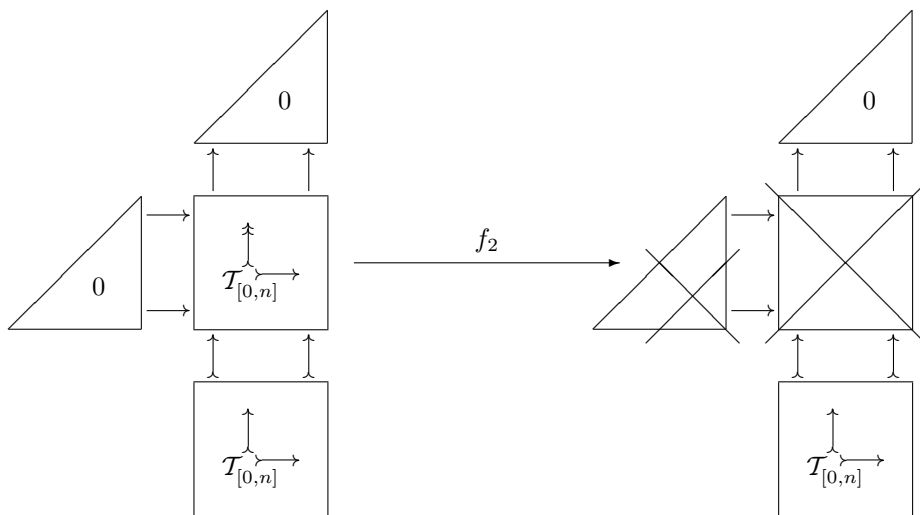

Then the fiber of f_2 in the sense of Segal, i.e. the simplicial set

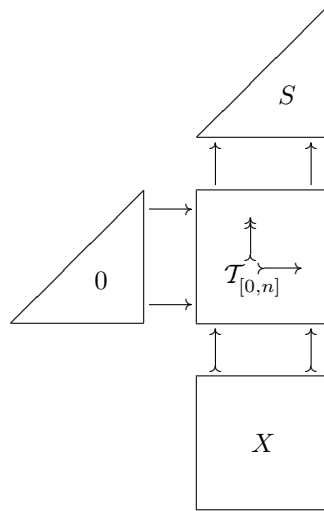

is homotopy equivalent to a much smaller-looking simplicial set. Precisely, if the fixed data X is given by the diagram

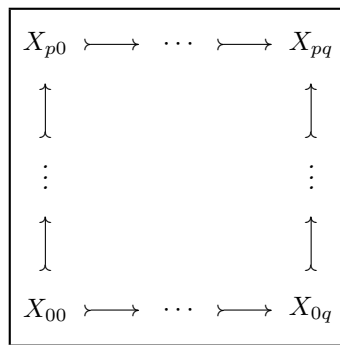

then the fiber $f_2^{-1}(X)$ is homotopy equivalent to the simplicial set we will denote

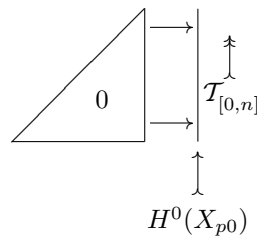

In particular, its homotopy type depends only on X_{p0} , and not on the entire simplex X . The symbol $H^0(X_{p0})$ stands for $X_{p0}^{\leq 0} = X_{p0}^{\leq 1}$. It is the bottom homology of X_{p0} , placed in degree 0. From now on we will denote it $X_{p0}^{\leq 1}$, as this is the easiest on the eye, having the fewest sub- and superscripts.

NOTATION 7.7. The object X_{p0} plays a crucial role in many homotopies. We will refer to it as X_{NW} . The notation means that we pick the North-West corner of the simplex X . We can, of course, also refer to X_{NE} , X_{SW} and X_{SE} . Naturally enough, these stand for the North-East, South-West and South-East corners of X respectively. But it turns out that of these X_{NW} and X_{SE} play a disproportionately important role. Of course, X_{NW} and X_{SE} are permuted by the duality and transposition symmetries. If one plays a major role, so must the other.

Proof of Lemma 7.6. Once again, the idea is to use our favorite homotopy. The fiber in the sense of Segal is the simplicial set

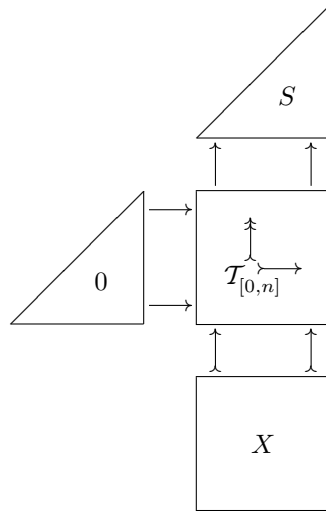

To this fiber we will apply a homotopy we will denote

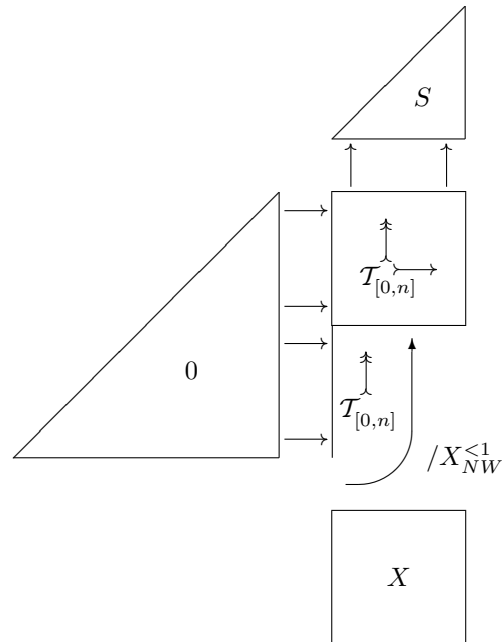

and as the notation is meant to suggest, the homotopy is a slight variation on our old friend. Now we need to explicitly describe the homotopy.

An n -simplex s_n in the fiber is a diagram of $M - V$ squares

$$s_n = \left(\begin{array}{ccccccc} & & & & & & 0 \\ & & & & & & \uparrow \\ & & & & & & \vdots \\ & & & & & & \uparrow \\ & & & & & & S_{0q} \\ & & & \uparrow & & & \uparrow \\ & & 0 & \longrightarrow & Y_{n0} & \longrightarrow & \cdots & \longrightarrow & Y_{nq} \\ & & \uparrow & & \uparrow & & \uparrow & & \uparrow \\ & & \vdots & & \vdots & & \vdots & & \vdots \\ & & \uparrow & & \uparrow & & \uparrow & & \uparrow \\ 0 & \longrightarrow & \cdots & \longrightarrow & Z_{0n} & \longrightarrow & Y_{00} & \longrightarrow & \cdots & \longrightarrow & Y_{0q} \\ & & & & \uparrow & & \uparrow & & & & \uparrow \\ & & & & X_{p0} & \longrightarrow & \cdots & \longrightarrow & X_{pq} \\ & & & & \uparrow & & \uparrow \\ & & & & \vdots & & \vdots \\ & & & & \uparrow & & \uparrow \\ & & & & X_{00} & \longrightarrow & \cdots & \longrightarrow & X_{0q} \end{array} \right)$$

and to define a homotopy, we need to associate to it $n + 1$ $(n + 1)$ -simplices. The i^{th} is given by the now familiar looking diagram

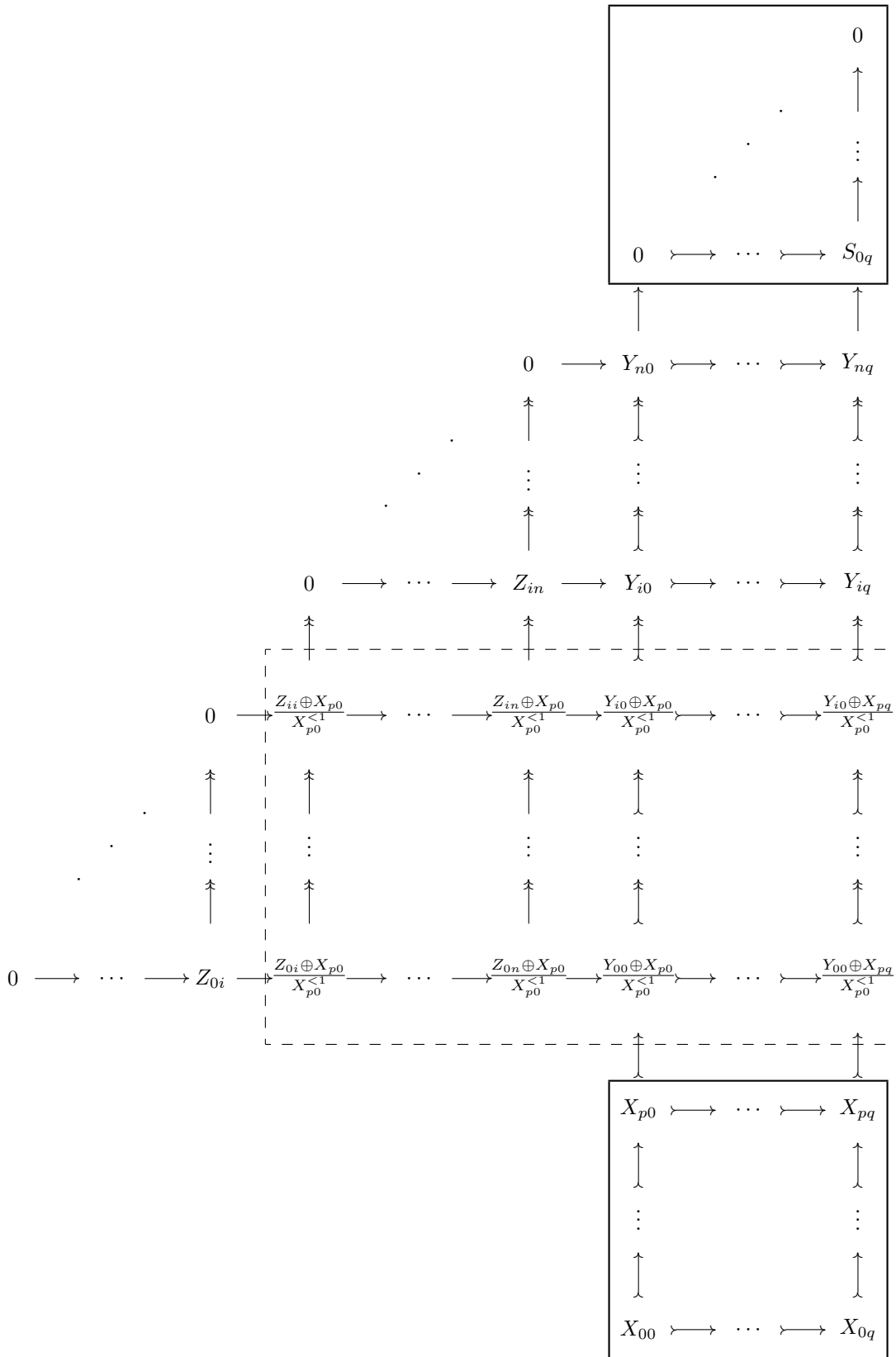

The reader should note that this is really nearly the same as the homotopy in the proof of Theorem 5.1. If the reader quickly refers back to the diagram defining the homotopy **, he will observe it to be identical with the above, except for the triangle of S 's at the top (which is harmless), and for the fact that in the rectangle surrounded by dashes, every term has been divided by $X_{NW}^{<1} = X_{p0}^{<1}$. Now we will explain what this means.

The point is that, in a triangulated category with a t -structure, there is a functorial way to divide an object $X \in \mathcal{T}^{\geq 0}$ by a subobject $A \in \mathcal{T}_{[0,0]}$. Precisely, this means that if $A \in \mathcal{T}_{[0,0]}$ and $X \in \mathcal{T}^{\geq 0}$ are given, together with a mono (in the exact category $\mathcal{T}^{\geq 0}$, where they both lie) $f : A \rightarrow X$, then one can form the quotient $\frac{X}{A}$, which is unique up to canonical isomorphism. In the above, put $A = X_{NW}^{<1}$. The objects Z_{jk} lie in $\mathcal{T}^{\geq 1}$, and hence the only map $A \rightarrow Z_{jk}$ is the zero map. But there is a canonical inclusion $A \rightarrow X_{NW}$, and hence a canonical map $A \rightarrow Z_{jk} \oplus X_{NW}$. The map $A \rightarrow Y_{0k} \oplus X_{NW}$ is defined simply to be the composite

$$A \rightarrow Z_{jk} \oplus X_{NW} \rightarrow Y_{0k} \oplus X_{NW}.$$

The highlighted box in the simplex above contains the quotients by this inclusion of A .

CAUTION 7.8. The reader should note that it is not entirely trivial that all the squares in the diagram above give rise to distinguished triangles. Modulo difficulties with mapping cones on triangles, it is nevertheless true. We will come back to this point in Sections II.1 and III.1, where we will give a more general discussion of why the variants of our favorite homotopy are all well defined.

The proof that the various squares are $M - V$ can wait until Sections II.1 and III.1, but what cannot wait is a computation of the map

$$Z_{jk} \oplus X_{NW} \rightarrow Y_{0k} \oplus X_{NW}.$$

Trivial as the computation is, it is so important that I will label it a proposition.

PROPOSITION 7.9. *In the simplex above, which is part of the definition of our favorite homotopy, the map*

$$Z_{jk} \oplus X_{NW} \rightarrow Y_{0k} \oplus X_{NW}$$

is the matrix

$$\begin{pmatrix} \alpha & -\beta \\ 0 & 1 \end{pmatrix}$$

where $\alpha : Z_{jk} \rightarrow Y_{0k}$ and $\beta : X_{NW} \rightarrow Y_{0k}$ are the natural structural morphisms of the simplex s_n .

Proof. There are several ways to prove this. We will indicate three, and leave the details as an exercise to the reader.

The first way is to remember that the distinguished triangles in the homotopy ** were defined in terms of direct summands on mapping cones of triangles. These were all very explicit, so we can now get in and compute.

The second way is to remember the metatheorem which tells us that, in order to compute what maps must arise from all the mapping cones, it is enough to treat the special case where the exact category is $\mathcal{A} \subset D^b(\mathcal{A})$. But then, the rectangle with the frame of dashes around it is determined uniquely, from the rest of the diagram, by pullback. This makes the computation somewhat easier.

The third and easiest way is to observe that we have a commutative square

$$\begin{array}{ccc} 0 & \longrightarrow & Y_{0j} \\ \uparrow & & \uparrow \\ Z_{jk} \oplus X_{p0} & \longrightarrow & Y_{0k} \oplus X_{NW} \end{array}$$

The map $Z_{jk} \oplus X_{p0} \longrightarrow Y_{0k} \oplus X_{NW}$ is defined in some universal way out of mapping cones on triangles from s_n . In particular, the map itself is a matrix in maps from s_n . The map is a matrix

$$\begin{pmatrix} a & b \\ c & d \end{pmatrix}$$

and there is really no freedom for a , c and d . But the composite

$$X_{NW} \longrightarrow Y_{0k} \oplus X_{NW} \longrightarrow Y_{0j}$$

must be zero, and since this is universally true (=for all choices of simplices) it is easy to deduce that $b = -\beta$. □

Coming back to the proof of Lemma 7.6, we note that we have so far constructed a homotopy which we denoted by

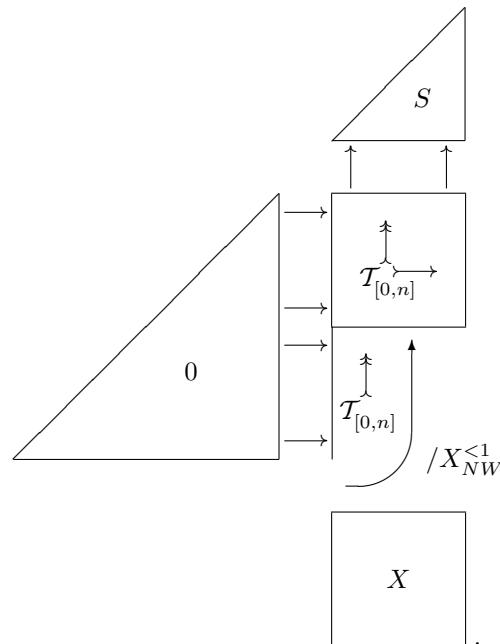

This homotopy links the identity with a map which we naturally denote

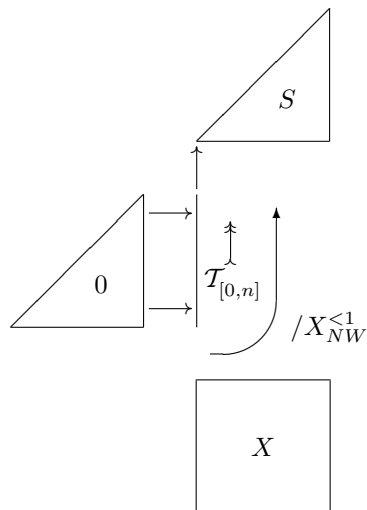

And the point is that this map factors through the simplicial set

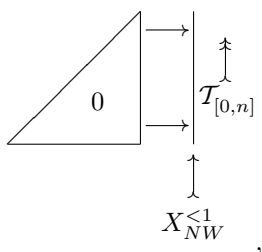

which is almost the same as the nerve of the category of monoepis; the difference is that we keep track of the kernels, and of a map $X_{NW}^{<1} \rightarrow Y_j$. Precisely, an n -simplex s_n in the simplicial set

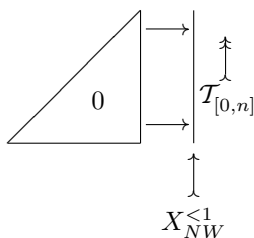

is a diagram of $M - V$ squares

$$\begin{array}{ccccccc}
 & & & & 0 & \longrightarrow & Y_n \\
 & & & & \uparrow & & \uparrow \\
 & & & \cdot & \vdots & & \vdots \\
 & & & \cdot & \uparrow & & \uparrow \\
 0 & \longrightarrow & \cdots & \longrightarrow & Z_{0n} & \longrightarrow & Y_0 \\
 & & & & & & \uparrow \\
 & & & & & & \boxed{X_{NW}^{<1}}
 \end{array}$$

Once again, we have framed the X_{NW} , as it is fixed. The fact that the map

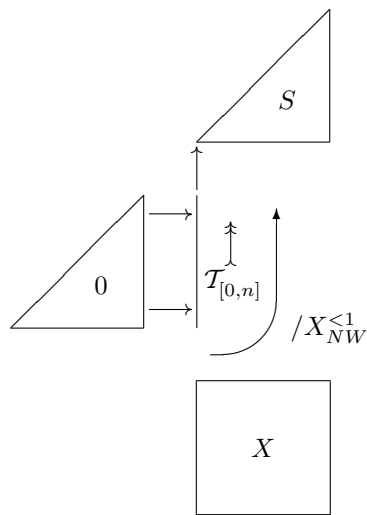

factors through

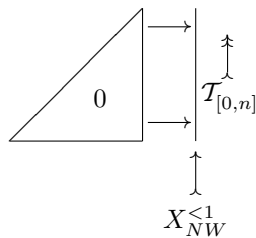

is essentially immediate; all the data we need to reconstruct the image of the simplex s_n is contained in a subsimplex which really lies in

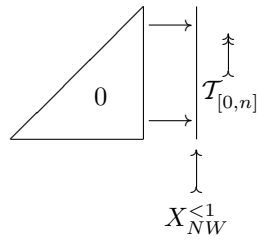

But we know more. We have really factored the identity quite explicitly. Precisely, we have constructed two maps

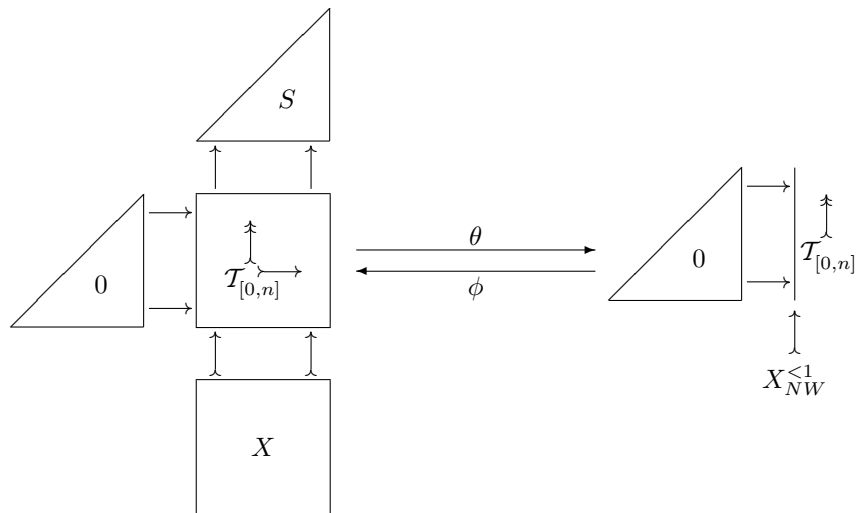

The maps θ and ϕ are really quite obvious. Let us however compute them once explicitly. An n -simplex s_n in the simplicial set

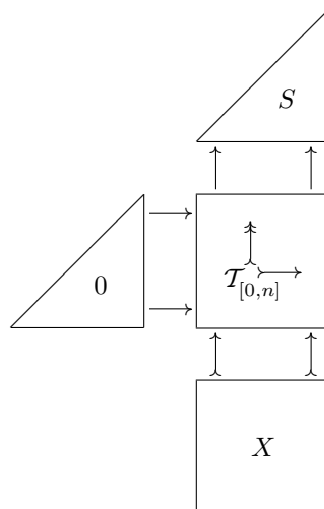

is a diagram

$$s_n = \left(\begin{array}{ccccccc} & & & & & & 0 \\ & & & & & & \uparrow \\ & & & & & & \vdots \\ & & & & & & \uparrow \\ & & & & & & S_{0q} \\ & & & \uparrow & & & \uparrow \\ & & 0 & \longrightarrow & Y_{n0} & \longrightarrow & \cdots & \longrightarrow & Y_{nq} \\ & & \uparrow & & \uparrow & & & & \uparrow \\ & & \vdots & & \vdots & & & & \vdots \\ & & \uparrow & & \uparrow & & & & \uparrow \\ 0 & \longrightarrow & \cdots & \longrightarrow & Z_{0n} & \longrightarrow & Y_{00} & \longrightarrow & \cdots & \longrightarrow & Y_{0q} \\ & & & & \uparrow & & \uparrow & & & & \uparrow \\ & & & & X_{p0} & \longrightarrow & \cdots & \longrightarrow & X_{pq} \\ & & & & \uparrow & & & & \uparrow \\ & & & & \vdots & & & & \vdots \\ & & & & \uparrow & & & & \uparrow \\ & & & & X_{00} & \longrightarrow & \cdots & \longrightarrow & X_{0q} \end{array} \right)$$

An n -simplex t_n in the simplicial set

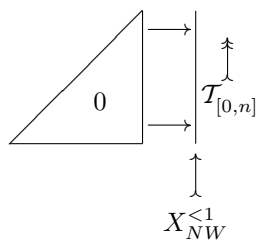

is a diagram

$$t_n = \left(\begin{array}{ccccccc} & & & & 0 & \longrightarrow & Y_n \\ & & & & \uparrow & & \uparrow \\ & & & \cdot & \uparrow & & \uparrow \\ & & & \cdot & \vdots & & \vdots \\ & & & \cdot & \uparrow & & \uparrow \\ 0 & \longrightarrow & \cdots & \longrightarrow & Z_{0n} & \longrightarrow & Y_0 \\ & & & & & & \uparrow \\ & & & & & & \boxed{X_{NW}^{<1}} \end{array} \right)$$

The map ϕ takes the simplex s_n to the simplex

$$\begin{array}{ccccccc} & & & & 0 & \longrightarrow & Y_{n0} \\ & & & & \uparrow & & \uparrow \\ & & & \cdot & \uparrow & & \uparrow \\ & & & \cdot & \vdots & & \vdots \\ & & & \cdot & \uparrow & & \uparrow \\ 0 & \longrightarrow & \cdots & \longrightarrow & Z_{0n} & \longrightarrow & Y_{00} \\ & & & & & & \uparrow \\ & & & & & & \boxed{X_{NW}^{<1}} \end{array}$$

whereas the map ψ takes t_n to the simplex

$$\begin{array}{ccccccc}
 & & & & & & 0 \\
 & & & & & & \uparrow \\
 & & & & & & \vdots \\
 & & & & & & \uparrow \\
 & & & & & & S_{0q} \\
 \hline
 & & & & & & \uparrow \\
 & & & & & & \frac{Y_n \oplus X_{pq}}{X_{NW}^{<1}} \\
 & & & & & & \uparrow \\
 & & & & & & \vdots \\
 & & & & & & \uparrow \\
 & & & & & & \frac{Y_0 \oplus X_{pq}}{X_{NW}^{<1}} \\
 \hline
 & & & & & & \uparrow \\
 & & & & & & X_{pq} \\
 & & & & & & \uparrow \\
 & & & & & & \vdots \\
 & & & & & & \uparrow \\
 & & & & & & X_{0q} \\
 \hline
 & & & & & & \uparrow \\
 & & & & & & \frac{Y_0 \oplus X_{p0}}{X_{NW}^{<1}} \\
 & & & & & & \uparrow \\
 & & & & & & \vdots \\
 & & & & & & \uparrow \\
 & & & & & & \frac{Y_n \oplus X_{p0}}{X_{NW}^{<1}} \\
 & & & & & & \uparrow \\
 & & & & & & 0 \\
 \hline
 0 & \longrightarrow & \cdots & \longrightarrow & Z_{0n} & \longrightarrow & \frac{Y_0 \oplus X_{p0}}{X_{NW}^{<1}} \longrightarrow \cdots \longrightarrow \frac{Y_0 \oplus X_{pq}}{X_{NW}^{<1}}
 \end{array}$$

The composites $\phi \circ \theta$ and $\theta \circ \phi$ are quite explicit. The beginning of the lemma proved that $\phi \circ \theta$ is homotopic to the identity. But $\theta \circ \phi$ takes the simplex t_n to the diagram

$$\begin{array}{ccccccc}
 & & & & 0 & \longrightarrow & \frac{Y_n \oplus X_{NW}}{X_{NW}^{<1}} \\
 & & & & \uparrow & & \uparrow \\
 & & & \cdot & \vdots & & \vdots \\
 & & & \cdot & \uparrow & & \uparrow \\
 0 & \longrightarrow & \cdots & \longrightarrow & Z_{0n} & \longrightarrow & \frac{Y_0 \oplus X_{NW}}{X_{NW}^{<1}} \\
 & & & & & & \uparrow \\
 & & & & & & \boxed{X_{NW}^{<1}}
 \end{array}$$

and the point is that this can be viewed as a translation with respect to some H -space structure. Precisely, there is a map

$$\left(\begin{array}{c} \begin{array}{ccc} \triangle & \begin{array}{c} \longrightarrow \\ \longrightarrow \end{array} & \begin{array}{c} \uparrow \\ \uparrow \\ \mathcal{T}_{[0,n]} \end{array} \\ \text{0} & & \end{array} \\ \uparrow \\ X_{NW}^{<1} \end{array} \right) \times \left(\begin{array}{c} \begin{array}{ccc} \triangle & \begin{array}{c} \longrightarrow \\ \longrightarrow \end{array} & \begin{array}{c} \uparrow \\ \uparrow \\ \mathcal{T}_{[0,n]} \end{array} \\ \text{0} & & \end{array} \\ \uparrow \\ X_{NW}^{<1} \end{array} \right) \\
 \downarrow \text{action} \\
 \begin{array}{ccc} \triangle & \begin{array}{c} \longrightarrow \\ \longrightarrow \end{array} & \begin{array}{c} \uparrow \\ \uparrow \\ \mathcal{T}_{[0,n]} \end{array} \\ \text{0} & & \end{array} \\ \uparrow \\ X_{NW}^{<1}$$

This map is induced by forming direct sums, and then dividing by the diagonal inclusion of $X_{NW}^{<1}$. The map $\theta \circ \phi$ is translation by the 0-cell

$$\begin{array}{ccc}
 0 & \longrightarrow & X_{NW} \\
 & & \uparrow \\
 & & X_{NW}^{<1}
 \end{array}$$

with respect to this action. This action gives a true H -space (unlike some other actions we will soon be considering on the same space). In particular, there is a

neutral element for the action, the 0-cell

$$\begin{array}{ccc}
 0 & \longrightarrow & X_{NW}^{<1} \\
 & & \uparrow \\
 & & X_{NW}^{<1}
 \end{array}$$

As we will see in the proof of Lemma 7.11, the simplicial set

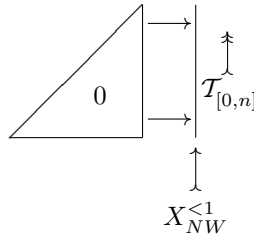

is connected. Translation by any 0-cell is homotopic to the identity. That proves that $\theta \circ \phi$ is homotopic to the identity. \square

REMARK 7.10. The reason the author has gone over the argument so carefully this time is that arguments like the above seem to be ubiquitous in this theory. One is always led to considering translations with respect to H -space structures, some of which are slightly fake. A fine example of this is Lemma 7.11.

The strategy of the proof of Theorems 4.8 and 7.1 is to show that the simplicial set

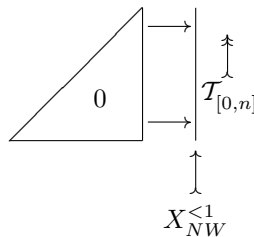

is contractible. But there is still the nuisance $X_{NW}^{<1}$ hanging off the bottom. We want to get rid of it.

LEMMA 7.11. Suppose $\mathcal{T} = D^b(\mathcal{A})$ with the usual t -structure, or $\mathcal{T} = Gr^b(\mathcal{A})$. If the simplicial set

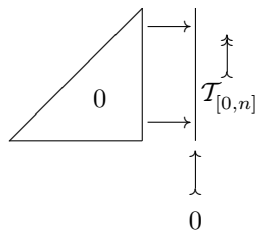

is contractible, then for any A an object of $\mathcal{T}_{[0,0]}$, the simplicial set

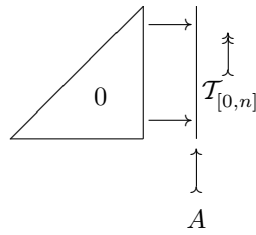

must also be contractible.

Proof. First observe that both simplicial sets are connected. (This is the part for which we need $\mathcal{T} = D^b(\mathcal{A})$ with the usual t -structure, or $\mathcal{T} = Gr^b(\mathcal{A})$.) For $\mathcal{T} = Gr^b(\mathcal{A})$, the connectedness is obvious. Suppose therefore $\mathcal{T} = D^b(\mathcal{A})$. If

$$\begin{array}{ccc} 0 & \longrightarrow & X \\ & & \uparrow \\ & & A \end{array}$$

is a 0-cell in

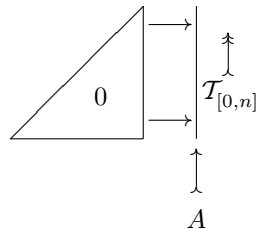

then we write $X \in D^b(\mathcal{A})$ as a complex

$$\dots \longrightarrow X^{-1} \longrightarrow X^0 \longrightarrow X^1 \longrightarrow \dots$$

and there is a map from X to its “brutal” truncation

$$\begin{array}{ccccccc} \dots & \longrightarrow & X^{n-1} & \longrightarrow & X^n & \longrightarrow & X^{n+1} & \longrightarrow & \dots \\ & & \downarrow & & \downarrow & & \downarrow & & \\ \dots & \longrightarrow & X^{n-1} & \longrightarrow & 0 & \longrightarrow & 0 & \longrightarrow & \dots \end{array}$$

This gives a truncation $X \rightarrow X^{tr}$, which is clearly monoepi if $n \geq 1$. But the map $A \rightarrow X^{tr}$ is also monoepi. If one keeps track of the kernels in the computation, this connects the simplex

$$\begin{array}{ccc} 0 & \longrightarrow & X \\ & & \uparrow \\ & & A \end{array}$$

to the simplex

$$\begin{array}{ccc} 0 & \longrightarrow & A \\ & & \uparrow \\ & & A \end{array}$$

and we immediately deduce connectedness.

Now the point is that for any A , the realization of

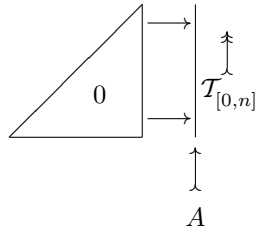

is a fake H -space, with the operation given by direct sum. The reason it is fake is because it is not *a priori* clear that there is an identity element. Note that this is different from the true H -space structure we considered, on the same space, on page 458. The true H -space structure was not just direct sum, but direct sum followed by division by some inclusion. Anyway, there is a multiplication map

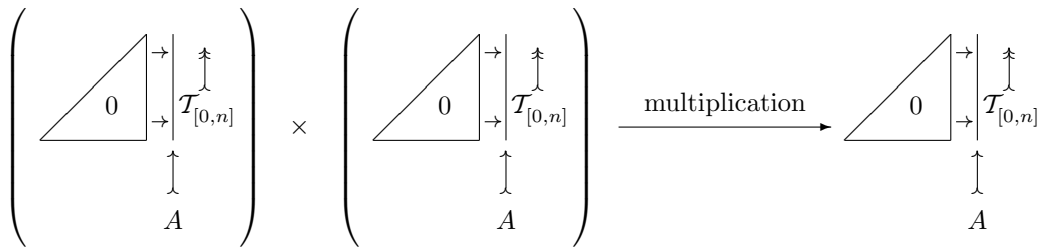

There is also an action of



again induced by direct sums. The idea of the proof will be to compare these actions.

The first observation is that the two maps

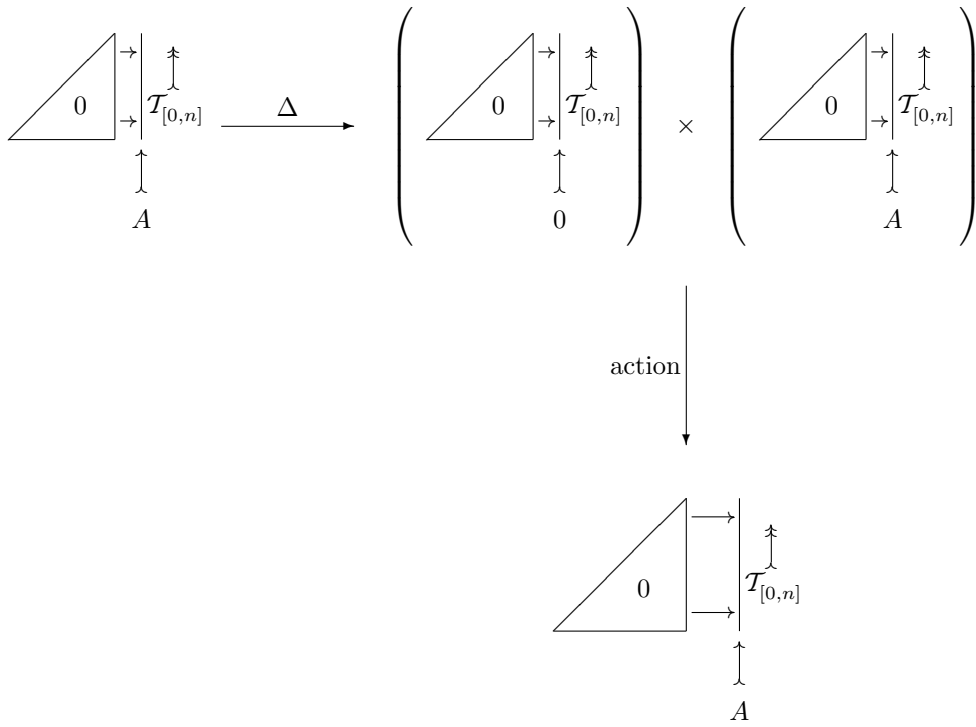

is homotopic to the identity. Here, Δ is the diagonal map. But concretely, this composite is the simplicial map sending the n -simplex

$$y_n = \left(\begin{array}{ccccccc} & & & & 0 & \longrightarrow & Y_n \\ & & & & \uparrow & & \uparrow \\ & & & \cdot & \uparrow & & \uparrow \\ & & & \vdots & \uparrow & & \vdots \\ & & \cdot & & \uparrow & & \uparrow \\ & & \vdots & & \uparrow & & \uparrow \\ 0 & \longrightarrow & \cdots & \longrightarrow & Z_{0n} & \longrightarrow & Y_0 \\ & & & & & & \uparrow \\ & & & & & & \boxed{A} \end{array} \right)$$

to the simplex

$$\begin{array}{ccccccc}
 & & & & 0 & \longrightarrow & Y_n \oplus Y_n \\
 & & & & \uparrow & & \uparrow \\
 & & & \cdot & \vdots & & \vdots \\
 & & & \cdot & \uparrow & & \uparrow \\
 & & & & & & \\
 0 & \longrightarrow & \cdots & \longrightarrow & Z_{0n} \oplus Z_{0n} & \longrightarrow & Y_0 \oplus Y_0 \\
 & & & & & & \uparrow \\
 & & & & & & i_2 \\
 & & & & & & \boxed{A}
 \end{array}$$

where $i_2 : A \rightarrow Y_0 \oplus Y_0$ is the inclusion in the second summand.

Now, up to a canonical automorphism of $Y_0 \oplus Y_0$, the map i_2 is equal to the diagonal; this immediately shows that the identity is homotopic to the map taking the n -simplex y_n to

$$\begin{array}{ccccccc}
 & & & & 0 & \longrightarrow & Y_n \oplus Y_n \\
 & & & & \uparrow & & \uparrow \\
 & & & \cdot & \vdots & & \vdots \\
 & & & \cdot & \uparrow & & \uparrow \\
 & & & & & & \\
 0 & \longrightarrow & \cdots & \longrightarrow & Z_{0n} \oplus Z_{0n} & \longrightarrow & Y_0 \oplus Y_0 \\
 & & & & & & \uparrow \\
 & & & & & & \Delta \\
 & & & & & & \boxed{A}
 \end{array}$$

and this map is nothing other than the composite

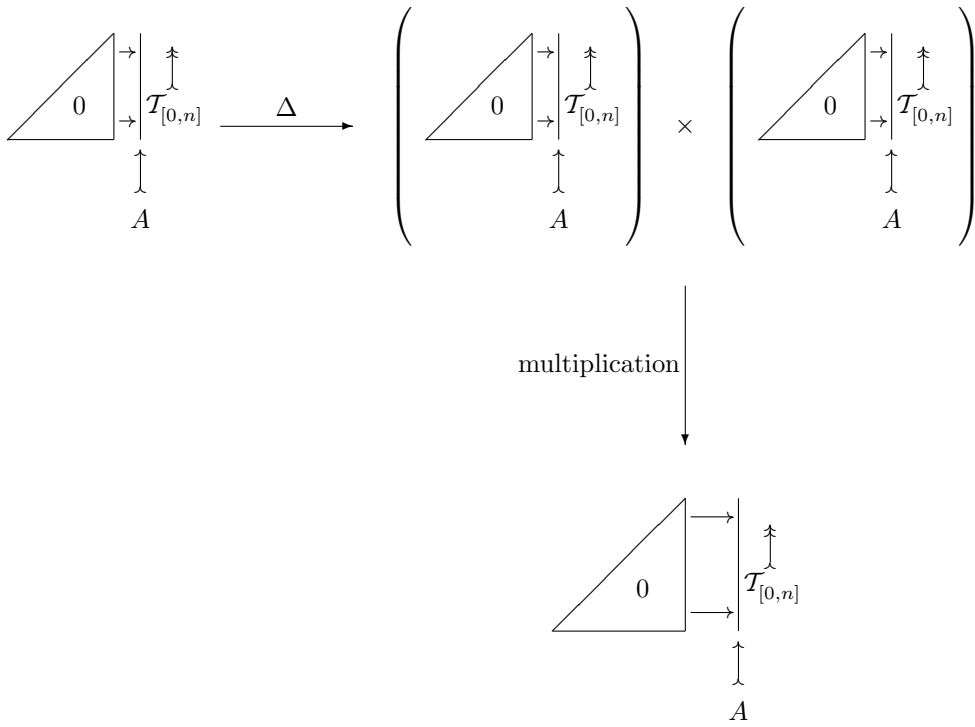

Next we will make a small computation in the homotopy groups of

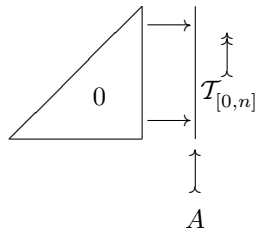

Because the homotopy groups of a space are a based invariant, let us choose a base point,

$$\begin{array}{ccc}
 0 & \longrightarrow & A \\
 & & \uparrow \\
 & & A
 \end{array}$$

We will show the vanishing of

$$\Pi_i \left(\left(\left(\begin{array}{ccc} & \longrightarrow & A \\ & & \uparrow \\ & & A \end{array} \right) \right) , \left(\begin{array}{ccc} 0 & \longrightarrow & A \\ & & \uparrow \\ & & A \end{array} \right) \right)$$

for every $i \geq 1$. Because we already know the connectedness of the space, this proves contractibility.

REMARK 7.12. Thomason pointed out that it is unnecessary to make this computation in the homotopy groups; one can argue more directly. This is of course true, but I wanted to underline the fact that we are only computing the higher homotopy of the space. This argument most definitely does not show the connectedness.

We need to show that any based map from a sphere into the pair

$$\left(\left(\begin{array}{c} \begin{array}{c} \triangle \\ \text{0} \end{array} \begin{array}{c} \xrightarrow{\quad} \\ \xrightarrow{\quad} \end{array} \\ \begin{array}{c} \uparrow \\ \mathcal{T}_{[0,n]} \\ \uparrow \\ A \end{array} \end{array} \right), \left(\begin{array}{c} 0 \longrightarrow A \\ \uparrow \\ A \end{array} \right) \right)$$

is null homotopic. Let ϕ be such a map. Recall that, if μ is the multiplication map on

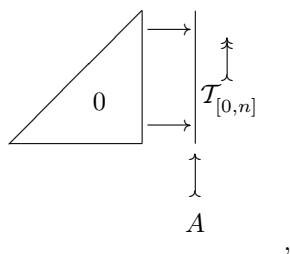

we know that the composite

$$\begin{array}{ccc}
 \begin{array}{c} \triangle \\ \text{0} \\ \rightarrow \mathcal{T}_{[0,n]} \\ \uparrow A \end{array} & \xrightarrow{\Delta} & \left(\begin{array}{c} \triangle \\ \text{0} \\ \rightarrow \mathcal{T}_{[0,n]} \\ \uparrow A \end{array} \right) \times \left(\begin{array}{c} \triangle \\ \text{0} \\ \rightarrow \mathcal{T}_{[0,n]} \\ \uparrow A \end{array} \right) \\
 & & \downarrow \mu \\
 & & \begin{array}{c} \triangle \\ \text{0} \\ \rightarrow \mathcal{T}_{[0,n]} \\ \uparrow A \end{array}
 \end{array}$$

is homotopic to the identity, by a homotopy that does not preserve the basepoint. Therefore the composite $\mu \circ \Delta \circ \phi$ is homotopic to ϕ , by a homotopy which need not preserve the base point. We will show that $\mu \circ \Delta \circ \phi$ is null homotopic. This shows first that ϕ is null homotopic by a homotopy not preserving the basepoint, but this homotopy can be adjusted to one preserving basepoints.

The point is that $\Delta \circ \phi$ is a map from a sphere into a product. It is therefore homotopic to a sum $\alpha_1 \oplus \alpha_2$ of two maps which factor through sections i_1 and i_2 of the product, respectively. It then suffices to show that $\mu \circ \alpha_j$ is null homotopic, for $j = 1, 2$. Even better, it suffices to prove that $\mu \circ i_j$ is null homotopic for $j = 1, 2$. As this is symmetric, it suffices to consider i_1 .

But the map $\mu \circ i_1$ is easy to compute. It takes the simplex

$$y_n = \left(\begin{array}{ccccccc} & & & & 0 & \longrightarrow & Y_n \\ & & & & \uparrow & & \uparrow \\ & & & \cdot & \vdots & & \vdots \\ & & & \cdot & \uparrow & & \uparrow \\ 0 & \longrightarrow & \cdots & \longrightarrow & Z_{0n} & \longrightarrow & Y_0 \\ & & & & & & \uparrow \\ & & & & & & \boxed{A} \end{array} \right)$$

to the simplex

$$\begin{array}{ccccccc}
 & & & & 0 & \longrightarrow & Y_n \oplus A \\
 & & & & \uparrow & & \uparrow \\
 & & & & \vdots & & \vdots \\
 & & & & \uparrow & & \uparrow \\
 0 & \longrightarrow & \cdots & \longrightarrow & Z_{0n} & \longrightarrow & Y_0 \oplus A \\
 & & & & & & \uparrow \Delta \\
 & & & & & & \boxed{A}
 \end{array}$$

But once again, up to a canonical automorphism of $Y_j \oplus A$, the diagonal equals the inclusion i_2 in the second factor. Thus the map $\mu \circ i_1$ factors through

$$\begin{array}{c}
 \begin{array}{c} \triangle \\ \text{0} \end{array} \begin{array}{c} \longrightarrow \\ \longrightarrow \end{array} \begin{array}{c} \uparrow \\ \uparrow \end{array} \mathcal{T}_{[0,n]} \\
 \uparrow \\
 0
 \end{array} ,$$

which is contractible. □

CAUTION 7.13. Let us elaborate a little on Remark 7.12. As we said, it is essential for the space

$$\begin{array}{c}
 \begin{array}{c} \triangle \\ \text{0} \end{array} \begin{array}{c} \longrightarrow \\ \longrightarrow \end{array} \begin{array}{c} \uparrow \\ \uparrow \end{array} \mathcal{T}_{[0,n]} \\
 \uparrow \\
 A
 \end{array}$$

to be connected in the above argument. To illustrate this point, suppose that instead of proceeding with the particular simplicial sets we chose, we replaced them with others. Precisely, suppose that instead of working with the diagram

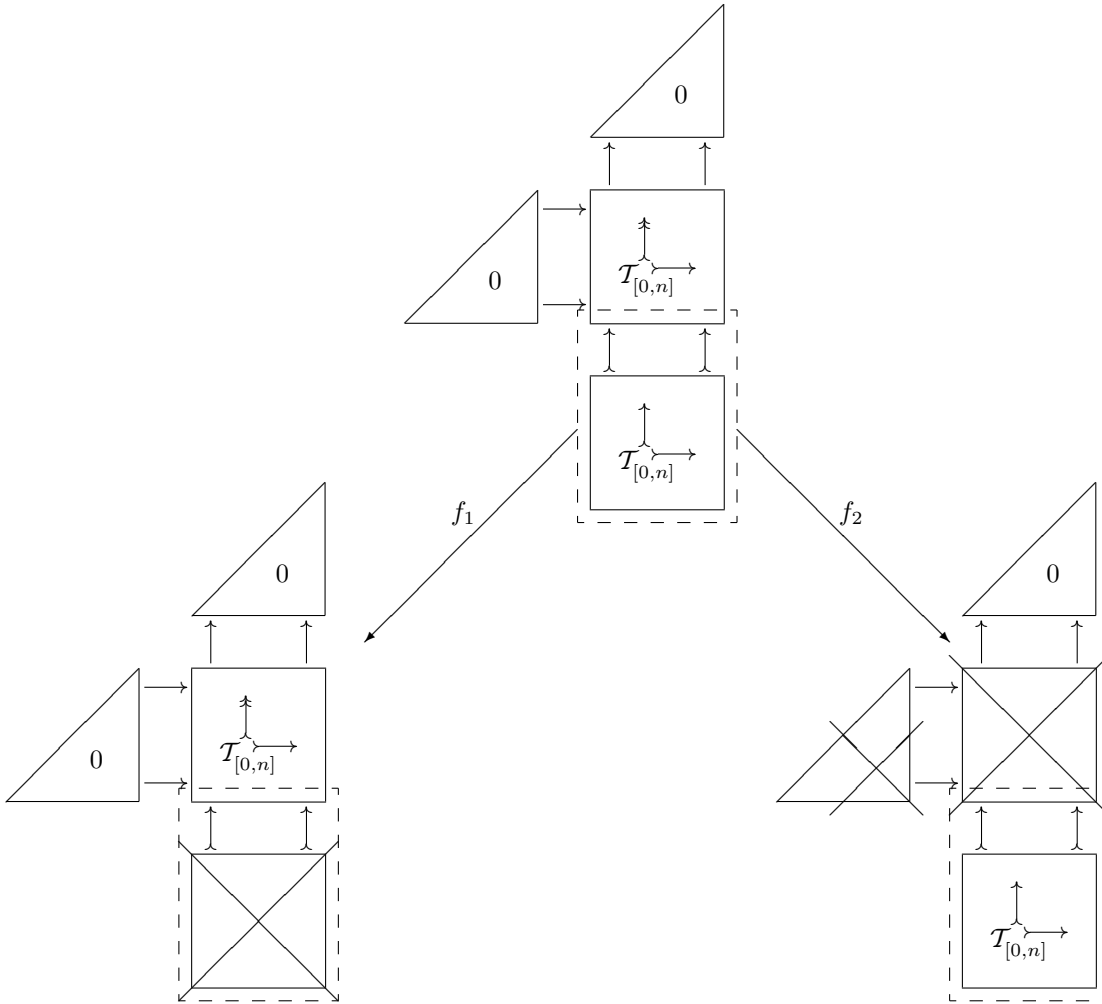

we decide to look at the diagram

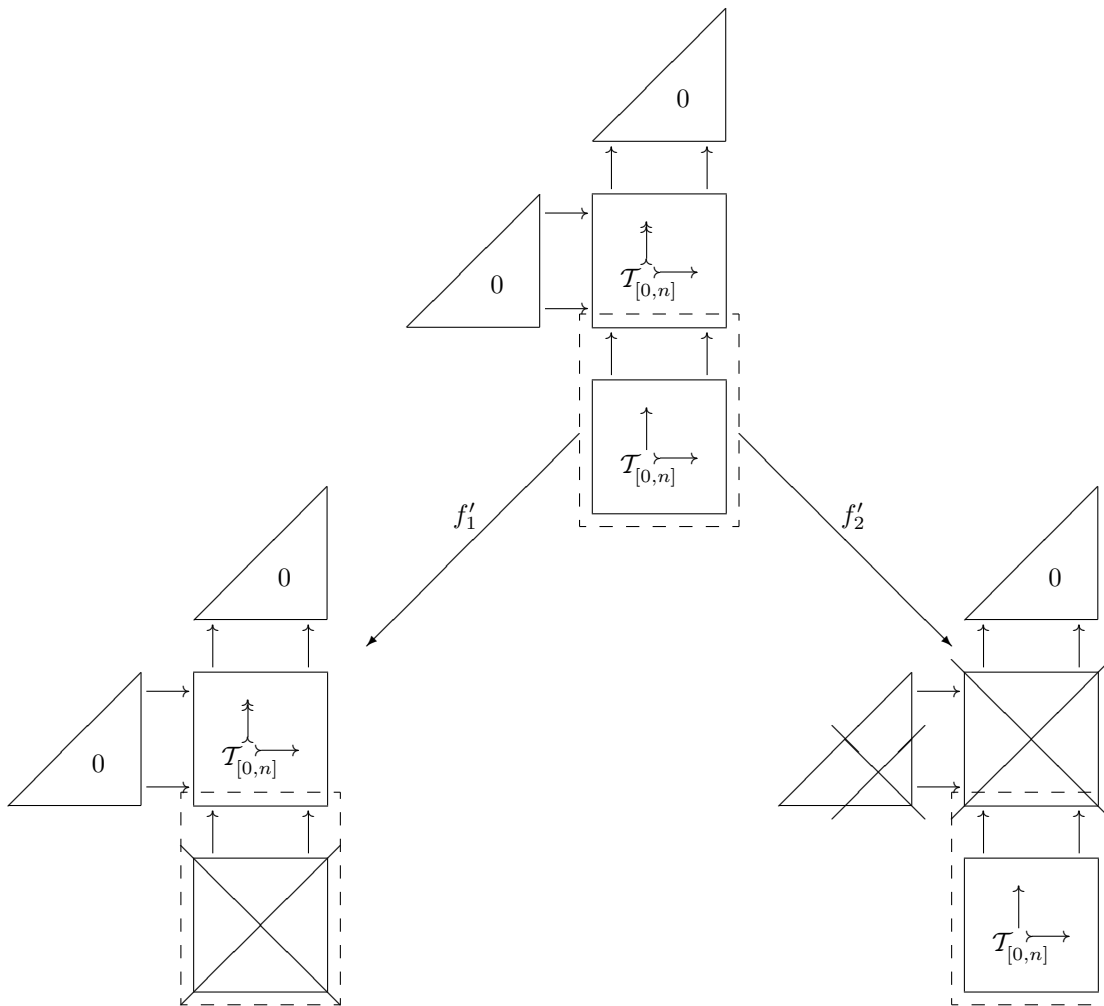

To make the difference easier to see, I have highlighted it with a dashbox. The vertical morphisms at the bottom of the diagram are no longer restricted to be mono.

Then most of the argument goes through unaltered. The map f'_1 is still trivially a homotopy equivalence. The homotopy of Lemma 7.6 still works, to show that the identity on the Segal fiber factors as $\phi\theta$ below

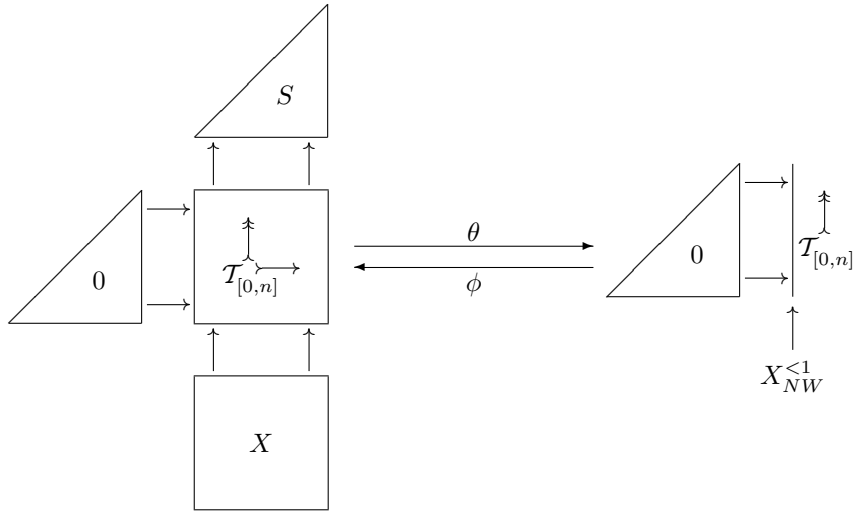

But this is as far as we get unscathed. The space

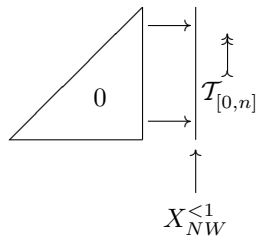

most definitely is not connected. It is still a fake H -space with respect to direct sum, and there is still an action of

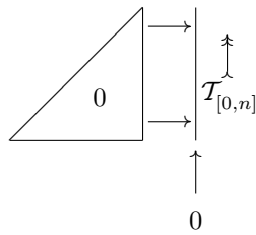

on it. The argument of Lemma 7.11 still proves that as long as

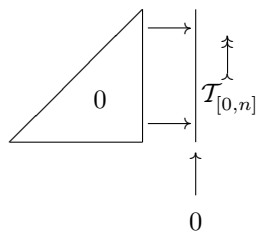

is contractible, so must also be the *connected component* of

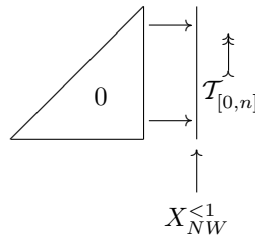

at the obvious basepoint. But that is all.

Lemma 7.11 seems to be a very useful trick in triangulated K -theory, and we will have occasion to use it in subsequent papers. Let us therefore formalise as a proposition the topological statement we used.

PROPOSITION 7.14. *Let X and Y be topological spaces. Suppose X is contractible and Y is connected. Suppose X is an H -space, suppose X acts on Y , and suppose Y is a fake H -space (i.e. there is a product, but no neutral element). Let the action be denoted*

$$X \times Y \xrightarrow{A} Y$$

and let the fake H -space structure be denoted

$$Y \times Y \xrightarrow{\mu} Y.$$

Suppose there is a map $\alpha : Y \rightarrow X$ such that the two composites

$$Y \begin{pmatrix} \alpha \\ \downarrow \\ 1 \end{pmatrix} \rightarrow X \times Y \downarrow Y \quad \text{and} \quad Y \xrightarrow{\Delta} Y \times Y \downarrow Y$$

are homotopic, and suppose further that for both inclusions of Y as a section of $Y \times Y$, the composites

$$Y \begin{pmatrix} * \\ \downarrow \\ 1 \end{pmatrix} \rightarrow Y \times Y \downarrow Y \quad \text{and} \quad Y \begin{pmatrix} 1 \\ \downarrow \\ * \end{pmatrix} \rightarrow Y \times Y \downarrow Y$$

are null homotopic. Then Y has the weak homotopy type of a contractible space. \square

For Constructions 4.6 and 4.7 we can do better; we will prove:

LEMMA 7.15. *For $Gr(\mathcal{A})$, we have that the projection*

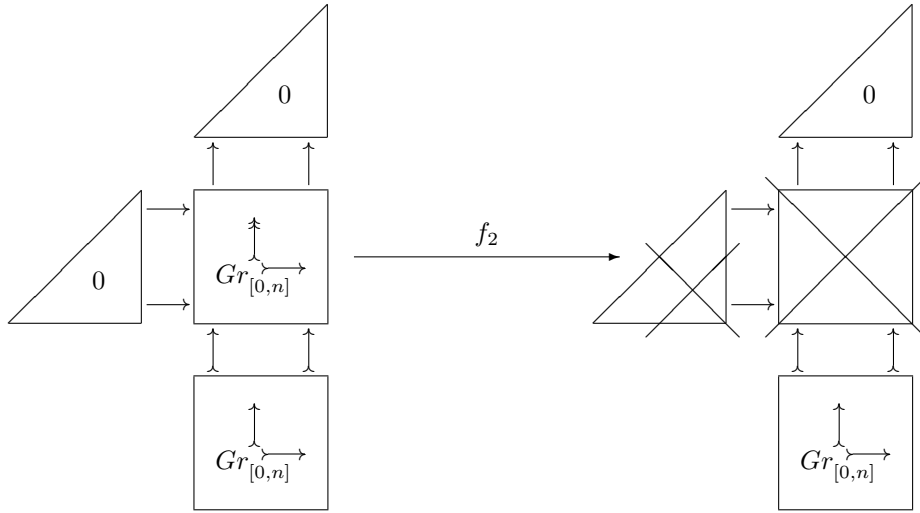

is a quasi-fibration. The homotopy fiber is

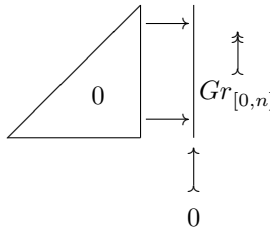

REMARK 7.16. This is of value especially in the case of Construction 4.6, i.e. without the differentials. We will not be able to show the contractibility of the homotopy fiber; but knowing that it is the homotopy fiber will allow us nevertheless to make some deductions.

Since this is the first place in the article in which we prove a map to be a quasi-fibration, it seems only right to explain what to do in some detail. All future proofs that maps are quasi-fibrations will follow the same pattern.

The topological fact which we use is

THEOREM 7.17. (Quillen’s Theorem B). *Let S . be a simplicial space, T . a simplicial set. Suppose $F : S \rightarrow T$. is a simplicial map (i.e. a simplicial map of simplicial spaces, where T . is declared to be a simplicial space with the discrete topology). Pick $X \in T_n$, then we call $f^{-1}(X)$ the fiber in S . over the n -simplex X . Suppose that for every X and every face map $\partial : T_n \rightarrow T_{n-1}$, the induced map $f^{-1}(X) \rightarrow f^{-1}(\partial X)$ is a homotopy equivalence. Then the realization of F is a quasi-fibration.*

Proof of Lemma 7.15. We need to show that the map

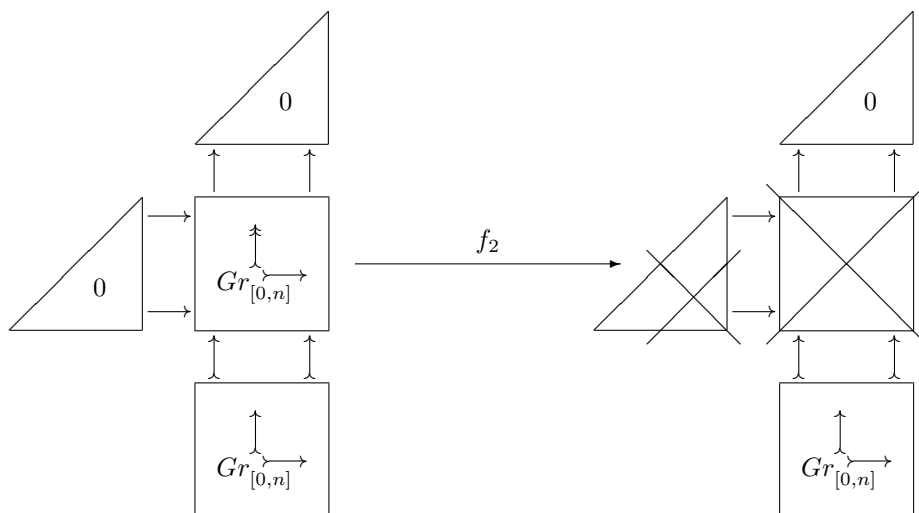

induces a quasifibration. If we realize first the simplicial structure that becomes degenerate on the target, we have a map from a bisimplicial space to a bisimplicial set, to which we can now apply Quillen's Theorem B , as above. Thus, it would suffice to prove that the face maps on the fibers, defined as in Quillen's Theorem B , all induce homotopy equivalences.

But Step 2 established a homotopy equivalence

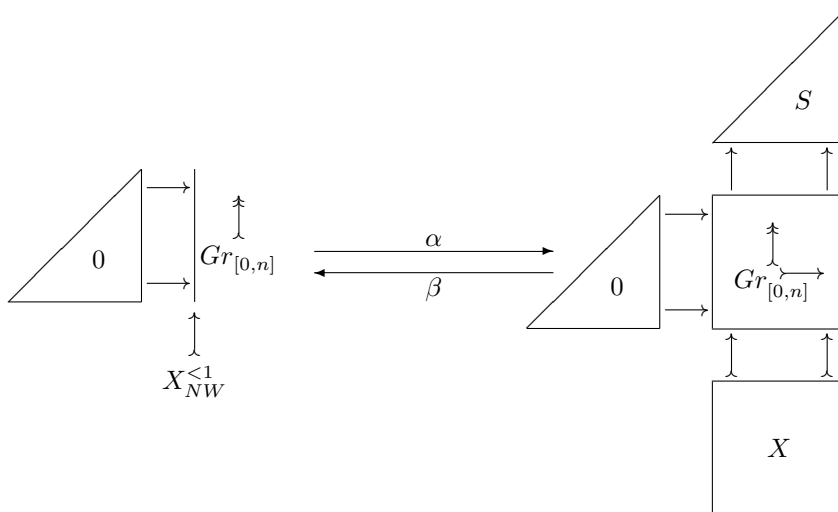

And because the maps α and β are so explicit, we can compute for any face map ∂ the composite

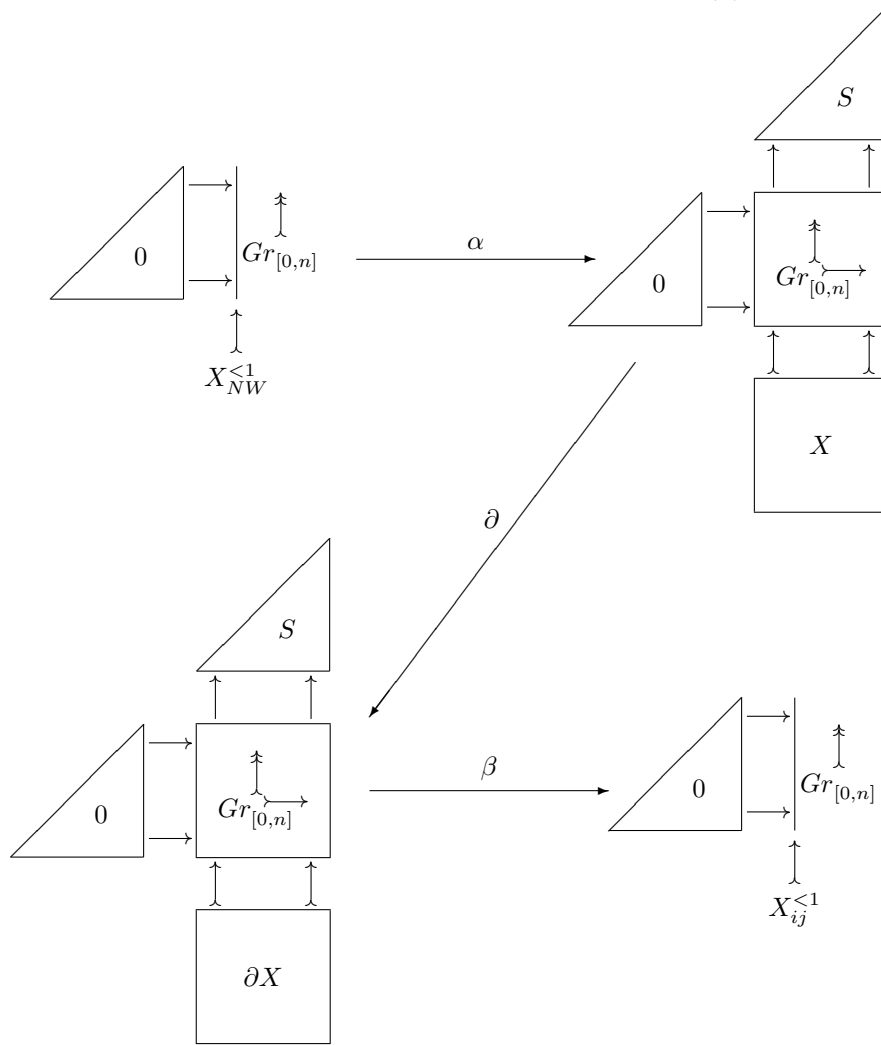

To prove ∂ a homotopy equivalence, it suffices to prove that the composite $\beta \circ \partial \circ \alpha$ is.

Our argument will run as follows. We will prove that, for any A , the map

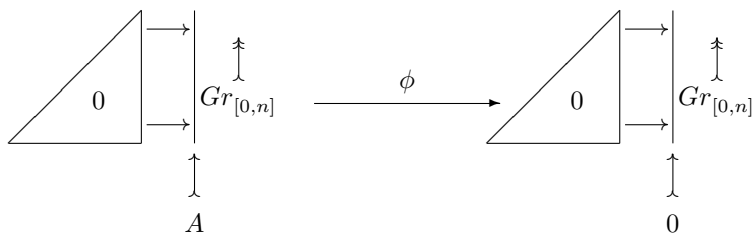

which forgets A induces a homotopy equivalence. There is a candidate inverse

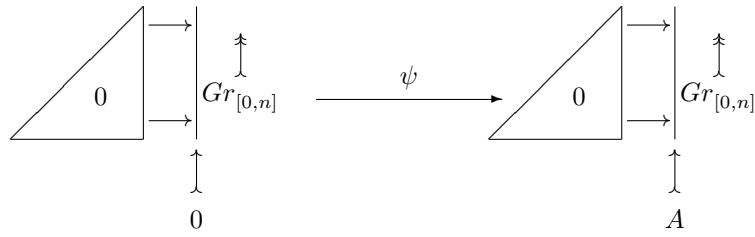

namely the map sending the simplex

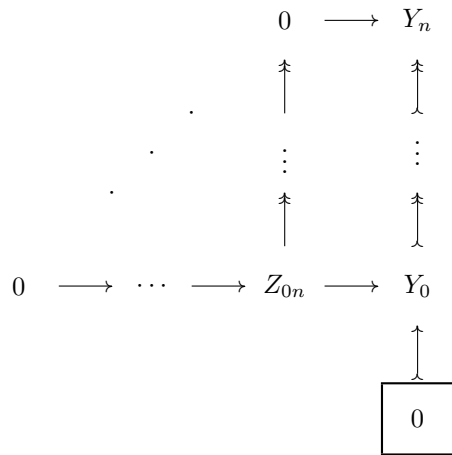

to the simplex

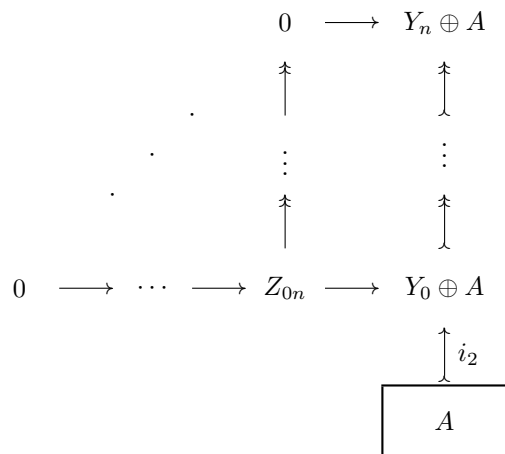

i_2 being the inclusion into the second summand. It is easy to show that $\phi \circ \psi$ is homotopic to 1.

Let us grant for now that $\psi \circ \phi$ is also a homotopy equivalence. We will come back to proving this before long; for now let us see how this can be used to complete the proof of the Lemma 7.15.

Study the composite $\phi \circ \beta \circ \partial \circ \alpha \circ \psi$. It is quite explicit and computable; the reader will easily verify that it is simply a translation in the H -space structure on

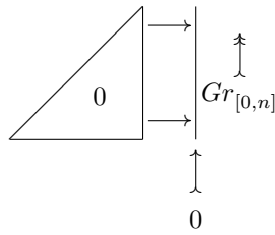

In particular, it is a homotopy equivalence. And because so are ϕ , β , α , and ψ , it follows that ∂ is a homotopy equivalence too.

It therefore remains to prove that ϕ and ψ are homotopy equivalences, and by the remarks above we need only show that $\psi \circ \phi$ is homotopic to the identity.

Let y_n be an n -simplex in

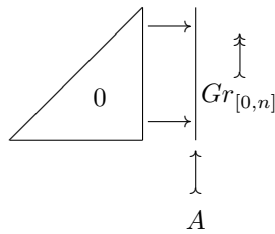

The map $\psi \circ \phi$ is easily computed to take this simplex

$$y_n = \left(\begin{array}{ccccccc} & & & & 0 & \longrightarrow & Y_n \\ & & & & \uparrow & & \uparrow \\ & & & \cdot & \vdots & & \vdots \\ & & & \cdot & \uparrow & & \uparrow \\ 0 & \longrightarrow & \cdots & \longrightarrow & Z_{0n} & \longrightarrow & Y_0 \\ & & & & & & \uparrow \\ & & & & & & \boxed{A} \end{array} \right)$$

to the simplex

$$\psi \circ \phi(y_n) = \left(\begin{array}{ccccccc} & & & & 0 & \longrightarrow & Y_n \oplus A \\ & & & & \uparrow & & \uparrow \\ & & & \cdot & \vdots & & \vdots \\ & & & \cdot & \uparrow & & \uparrow \\ 0 & \longrightarrow & \cdots & \longrightarrow & Z_{0n} & \longrightarrow & Y_0 \oplus A \\ & & & & & & \uparrow \Delta \\ & & & & & & \boxed{A} \end{array} \right) .$$

This is of course translation in the fake H -space structure. But now write down a homotopy whose cells are

$$\begin{array}{ccccccc} & & & & 0 & \longrightarrow & Y_n \oplus Y_n^{<1} \\ & & & & \uparrow & & \uparrow \\ & & & \cdot & \vdots & & \vdots \\ & & & \cdot & \uparrow & & \uparrow \\ & & & 0 & \longrightarrow & \cdots & \longrightarrow & Z_{in} \oplus C_{in} & \longrightarrow & Y_i \oplus Y_i^{<1} \\ & & & \uparrow & & \uparrow & & \uparrow \\ 0 & \longrightarrow & Z_{ii} \oplus B_i & \longrightarrow & \cdots & \longrightarrow & Z_{in} \oplus B_i & \longrightarrow & Y_i \oplus A \\ \uparrow & & \uparrow & & & & \uparrow & & \uparrow \\ \vdots & & \vdots & & & & \vdots & & \vdots \\ \uparrow & & \uparrow & & & & \uparrow & & \uparrow \\ 0 & \longrightarrow & \cdots & \longrightarrow & Z_{0i} & \longrightarrow & Z_{0i} \oplus B_0 & \longrightarrow & \cdots & \longrightarrow & Z_{0n} \oplus B_0 & \longrightarrow & Y_0 \oplus A \\ & & & & & & & & & & & & \uparrow \\ & & & & & & & & & & & & \boxed{A} \end{array}$$

The point about this homotopy is that $A \longrightarrow Y_j^{<1}$ is clearly monoepi. It is mono by hypothesis, and epi because $Y_j^{<1}$ has no higher homology. This makes the right hand column a column of monoepis, and anyone can compute the kernels; we have disturbed our original simplex by a simplex in the rigid K -theory of \mathcal{A} .

So far, this is not special to Gr . But now we observe that the inclusion $A \hookrightarrow Y_j \oplus Y_j^{<0}$ factors canonically through $A \hookrightarrow Y_j$. This is very special to Gr , and we deduce a homotopy having cells

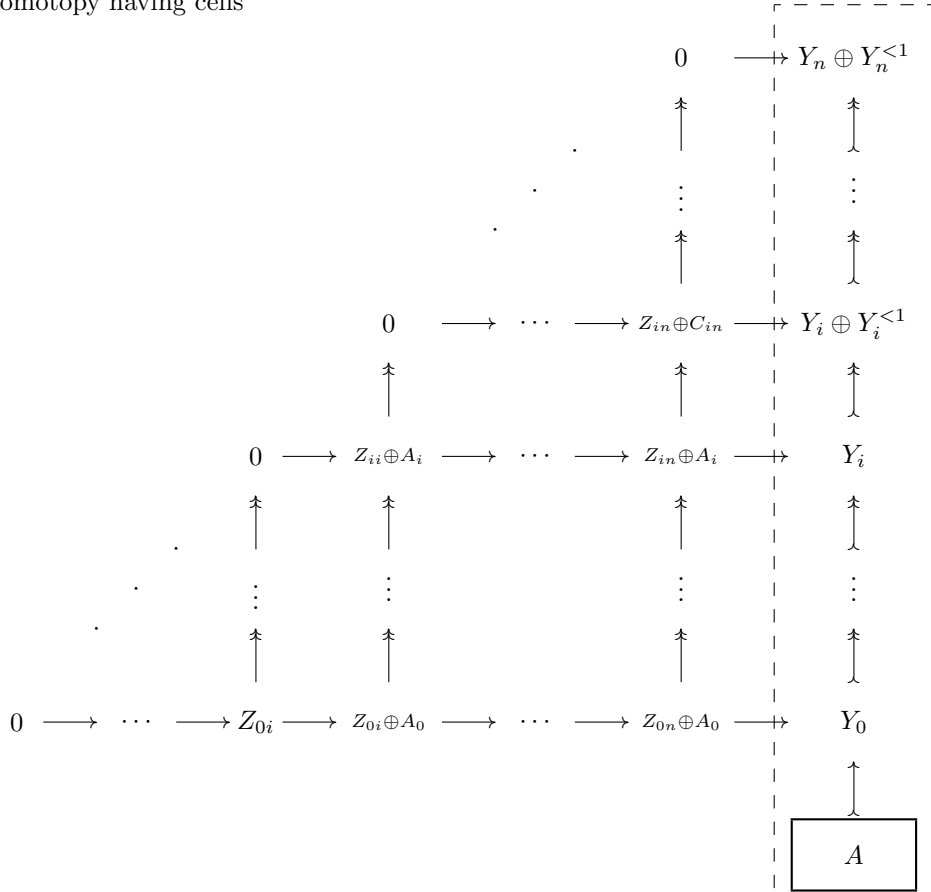

and with these two homotopies we have connected the map $\psi \circ \phi$ with the identity. \square
 From now on we will deal only with the simplicial sets

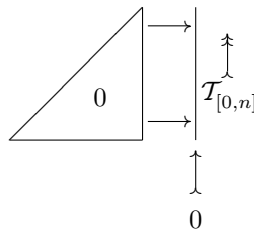

In every case, Lemma 7.11 tells us that their contractibility would establish Theorem 7.1 or 4.8. In the case of $Gr_{[0,n]}(\mathcal{A})$, we have proved the stronger statement that this is the homotopy fiber. Henceforth, we will drop the 0 at the bottom; we will denote this simplicial set by

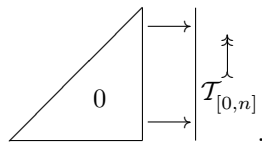

8. First proof of Theorem 4.8. Motivation. In broad strokes, the proof goes as follows. Let F_n be the homotopy fiber of the map

$$\begin{array}{ccc} \boxed{\begin{array}{c} \uparrow \\ Gr_{[1,n]} \rightarrow \end{array}} & \longrightarrow & \boxed{\begin{array}{c} \uparrow \\ Gr_{[0,n]} \rightarrow \end{array}} \end{array}$$

Then there is a commutative diagram, whose rows are fibrations

$$\begin{array}{ccccc} F_n & \longrightarrow & \boxed{\begin{array}{c} \uparrow \\ Gr_{[1,n]} \rightarrow \end{array}} & \longrightarrow & \boxed{\begin{array}{c} \uparrow \\ Gr_{[0,n]} \rightarrow \end{array}} \\ \downarrow \alpha_n & & \downarrow & & \downarrow \\ F_{n+1} & \longrightarrow & \boxed{\begin{array}{c} \uparrow \\ Gr_{[1,n+1]} \rightarrow \end{array}} & \longrightarrow & \boxed{\begin{array}{c} \uparrow \\ Gr_{[0,n+1]} \rightarrow \end{array}} \end{array}$$

In this section, we will prove two main lemmas:

- LEMMA 1. (=Lemma 8.8) $\alpha_n : F_n \rightarrow F_{n+1}$ induces a homotopy equivalence.
- LEMMA 2. (=Lemma 8.10) $\alpha_n : F_n \rightarrow F_{n+1}$ is null homotopic.

Taken together, the lemmas establish the contractibility of F_n , and hence Theorem 4.8.

From Section 7 we already have a simplicial model for F_n , namely the simplicial set

$$\begin{array}{c} \triangle \\ \text{0} \end{array} \begin{array}{c} \longrightarrow \\ \longrightarrow \end{array} \begin{array}{c} \uparrow \\ Gr_{[0,n]} \end{array}$$

With this simplicial model, Lemma 2 turns out to be trivial, with the one proviso that it uses the coherent differentials. To prove Lemma 1, we will need another simplicial model for F_n .

The idea is simple enough. We label an arrow \dashrightarrow if it happens to be an H^0 isomorphism. Consider the simplicial set

$$\boxed{\begin{array}{c} \uparrow \\ \dashrightarrow \\ Gr_{[0,n]} \rightarrow \end{array}},$$

which is of course defined by requiring that the vertical maps be H^0 -isomorphisms. It is very easy to see that the inclusion

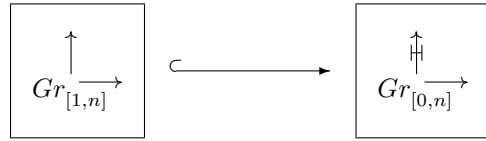

induces a homotopy equivalence. Clearly, the simplicial map

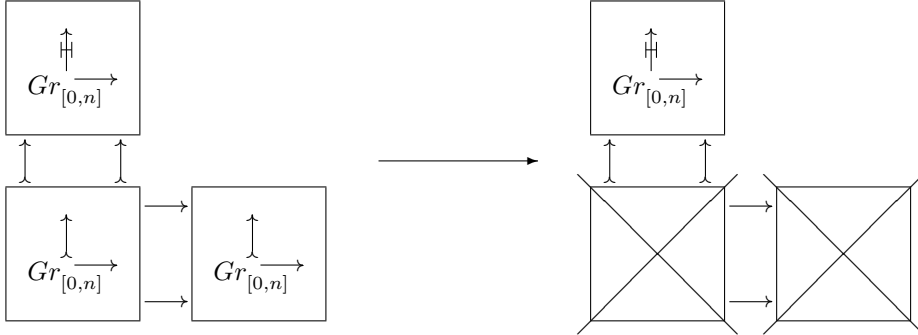

also induces a homotopy equivalence. What would be nice is if the map

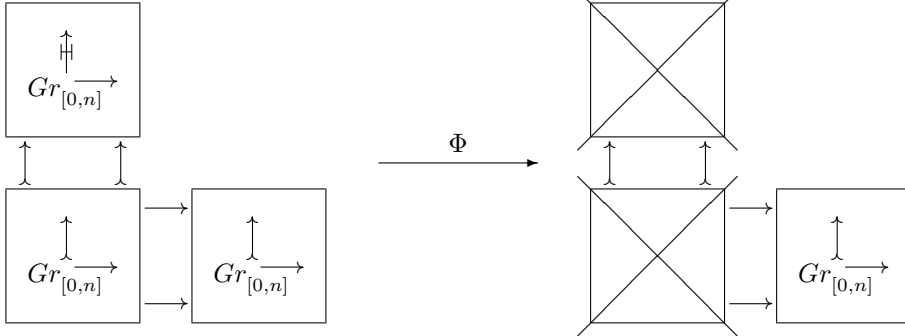

induced a quasifibration. This would give us another model for the homotopy fiber F_n , and this model is the simplicial set

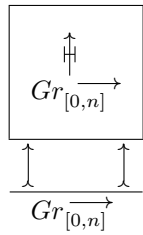

which is just the fiber over 0. It can easily be shown that the natural inclusion of the smaller simplicial set, where the objects along the bottom line are restricted to lie in $Gr_{[1,n]}$, that is the set

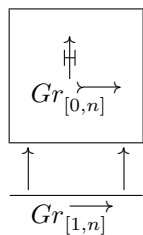

induces a homotopy equivalence. And this last simplicial set is very amenable to proving Lemma 1.

Unfortunately, I have not been able to prove the map

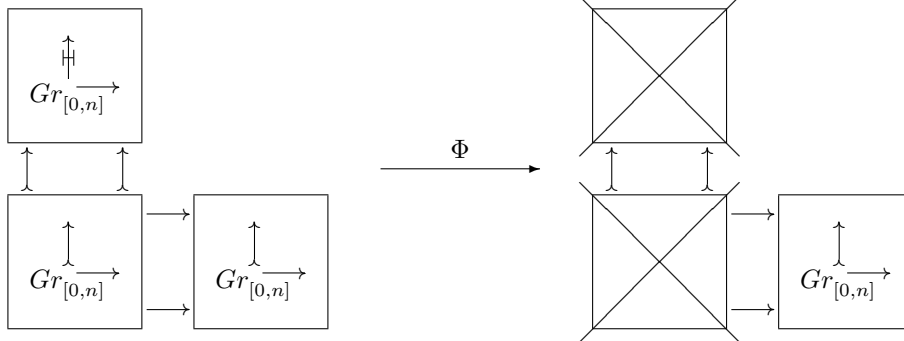

a quasi-fibration. Actually, even this is not entirely true. I have a proof which works for the construction without the differentials, Construction 4.6. I assure the reader that he does not want to see that proof. The proof involves homotopies defined on the second barycentric subdivision of the fibers.

What we have in this section instead is a very indirect proof of the existence of a homotopy equivalence

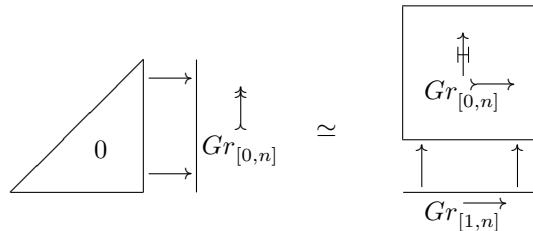

Thus, even without showing that Φ is a quasi-fibration, we succeed in proving that the fiber over zero is the homotopy fiber.

The proof occupies Lemmas 8.1–8.7, and it has about it all the feel of a mission to the moon; you go very far out, and come back to a result that is not actually far removed from the starting point.

End of Motivation

The virtue of this proof is that right until the very last step, the argument is valid for both Construction 4.6 and Construction 4.7. This will allow us to say some things about Construction 4.6, even though we do not know its homotopy type.

Again, we will break the proof into steps.

LEMMA 8.1. *The simplicial set*

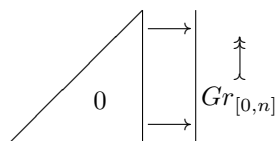

is also the homotopy fiber of the map

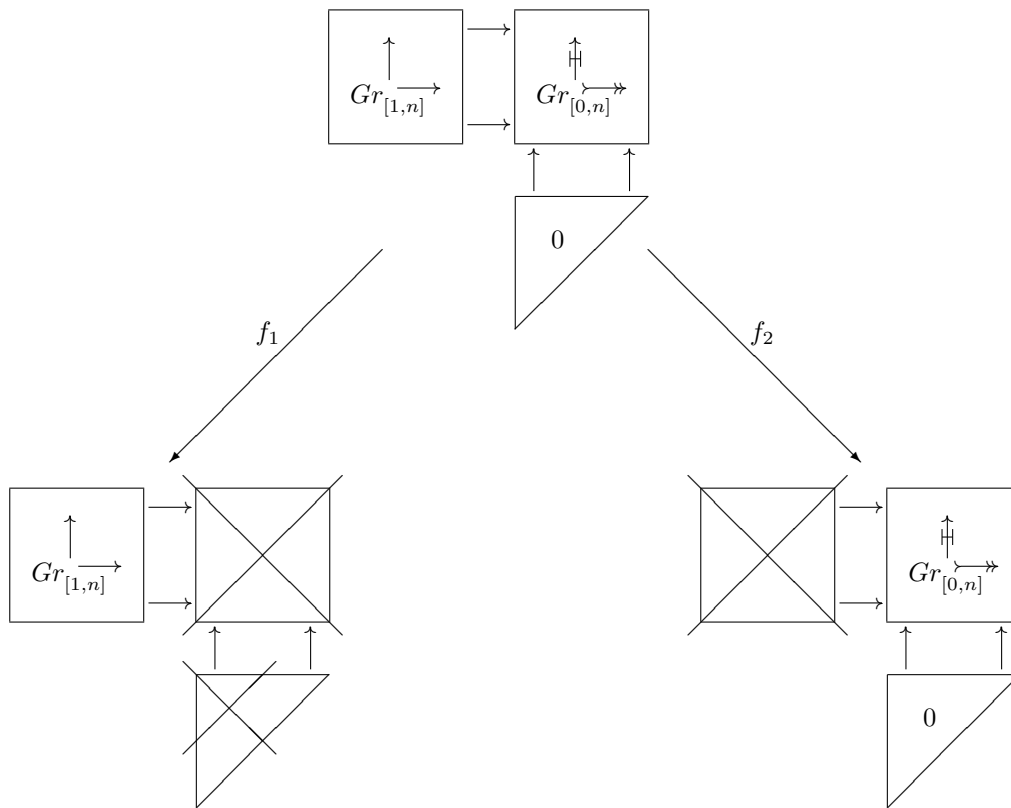

It is very easy to prove that f_2 is a homotopy equivalence; the fiber

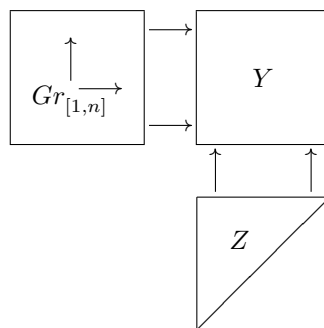

is contractible, the contracting homotopy being

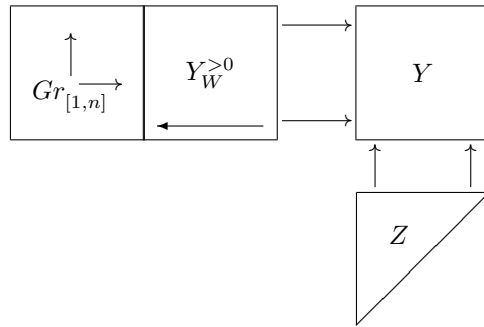

This is of course the contraction to the terminal object; the homotopy send the cell

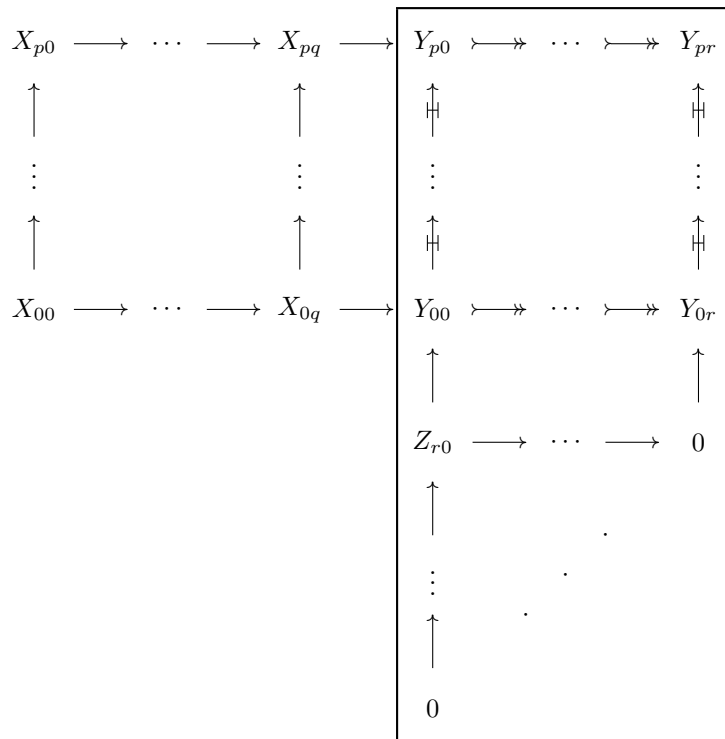

to the collection of $q + 1$ $(q + 1)$ -simplices, the $(q - i)^{th}$ of which is

$$\begin{array}{ccccccc}
 \overbrace{X_{p0} \longrightarrow \cdots \longrightarrow X_{pi}} & & \overbrace{Y_{p0}^{>0} \longrightarrow \cdots \longrightarrow Y_{p0}^{>0}} & \longrightarrow & Y_{p0} \rightrightarrows \cdots \rightrightarrows Y_{pr} \\
 \uparrow & & \uparrow & & \uparrow & & \uparrow \\
 \vdots & & \vdots & & \vdots & & \vdots \\
 \uparrow & & \uparrow & & \uparrow & & \uparrow \\
 \underbrace{X_{00} \longrightarrow \cdots \longrightarrow X_{0i}}_{(i+1)\text{ terms}} & & \underbrace{Y_{00}^{>0} \longrightarrow \cdots \longrightarrow Y_{00}^{>0}}_{(q-i+1)\text{ terms}} & \longrightarrow & Y_{00} \rightrightarrows \cdots \rightrightarrows Y_{0r} \\
 & & & & \uparrow & & \uparrow \\
 & & & & Z_{r0} \longrightarrow \cdots \longrightarrow 0 & & \\
 & & & & \uparrow & & \\
 & & & & \vdots & & \\
 & & & & \uparrow & & \\
 & & & & 0 & &
 \end{array}$$

(Note that this homotopy will *not* work in a triangulated category \mathcal{T} ; the natural map to the truncation is $Y_{i0} \rightarrow Y_{i0}^{\geq 1}$).

Thus, to prove Lemma 8.1, it suffices to show that f_2 is quasifibration (the fiber over $X = 0$ being right). Once again, we use our favorite homotopy. To apply Quillen's Theorem B we need to study the Segal fiber of f_2 . It is the simplicial set

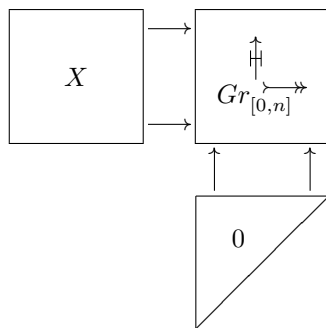

and we apply the homotopy

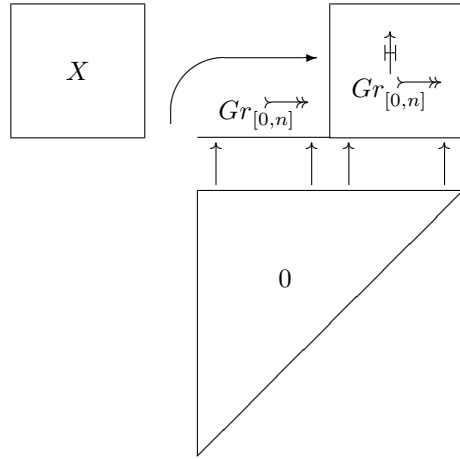

The only thing that needs caution is the proof that the cells of the homotopy do not depart from their simplicial set. The cells of the homotopy are

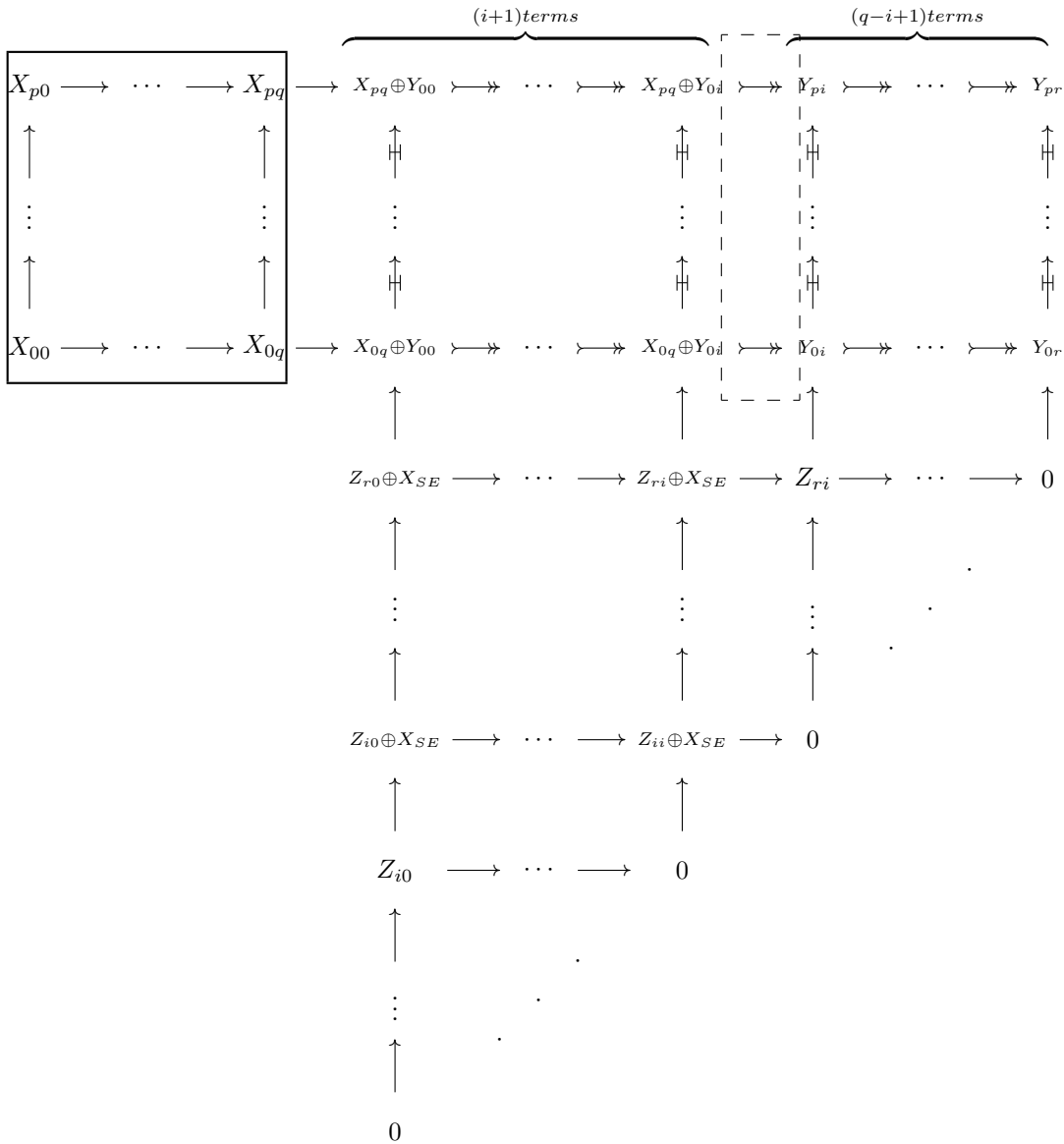

and the key point is that the cells of the homotopy are legitimate, because the maps inside the dashbox, namely $X_{iq} \oplus Y_{0j} \rightarrow Y_{ij}$, are indeed mono. The reason we can be certain of this is that $H^0(X_{iq}) = 0$, and $Y_{0j} \rightarrow Y_{ij}$ is mono.

This proves that the identity on the fiber factors, up to homotopy, through the simplicial set

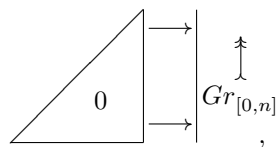

and it is easy to check that this factorization induces a homotopy equivalence. The point is that we have two maps

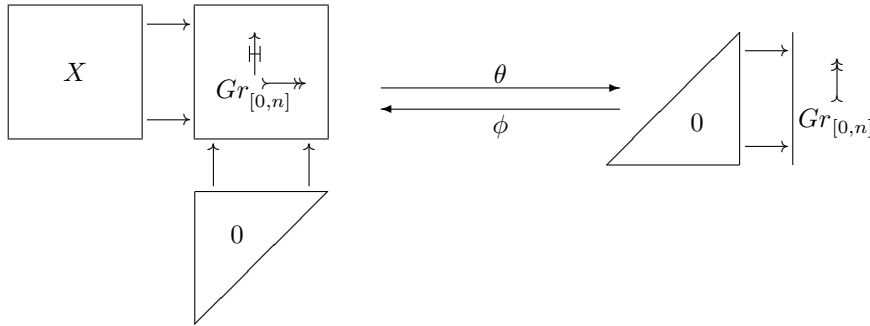

We have just proved that the composite $\phi \circ \theta$ is homotopic to the identity. The composite $\theta \circ \phi$ is easier; it is easily computed to be nothing other than a translation in the H -space structure of

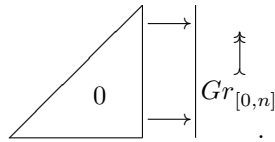

Thus the fibers have a homotopy type independent of X . It is easy to verify that the face maps on X induce homotopy equivalences of the fibers; see Lemma 7.15. Hence f_1 is a quasi-fibration. \square

LEMMA 8.2. *The natural projection*

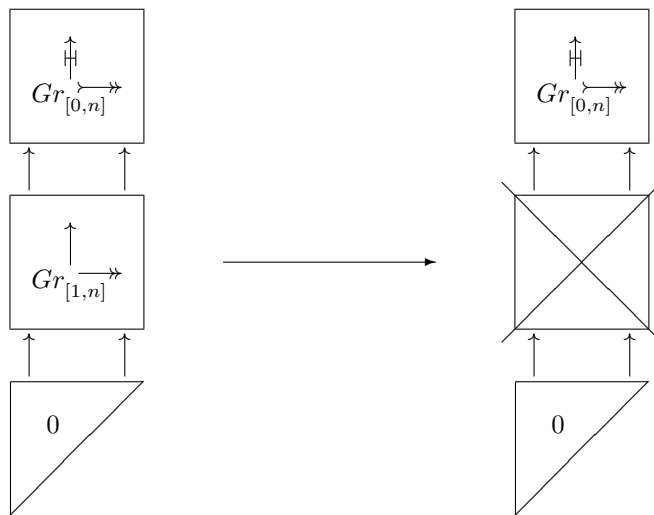

is a homotopy equivalence.

Proof. The fiber (in the sense of Segal) is the simplicial set

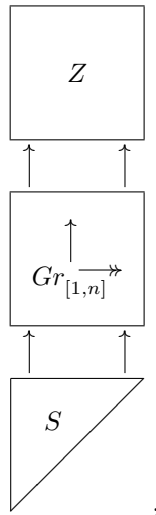

which is contracted by the homotopy

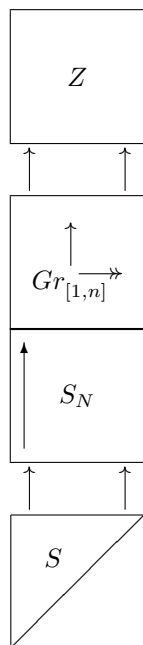

LEMMA 8.3. *The natural map*

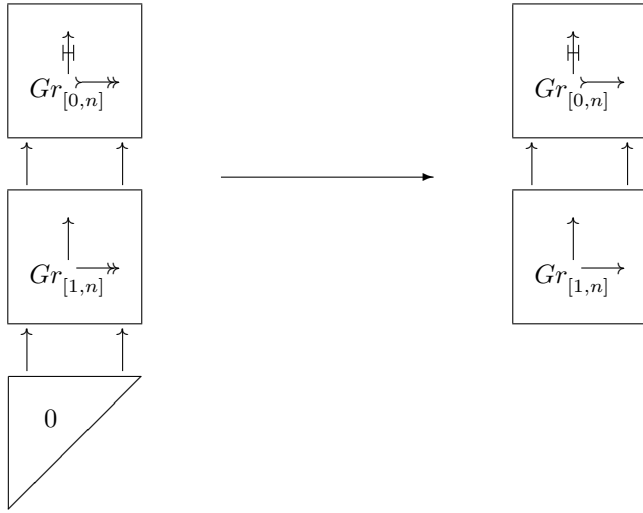

is a homotopy equivalence.

Proof. Study the quarti-simplicial set and two projections

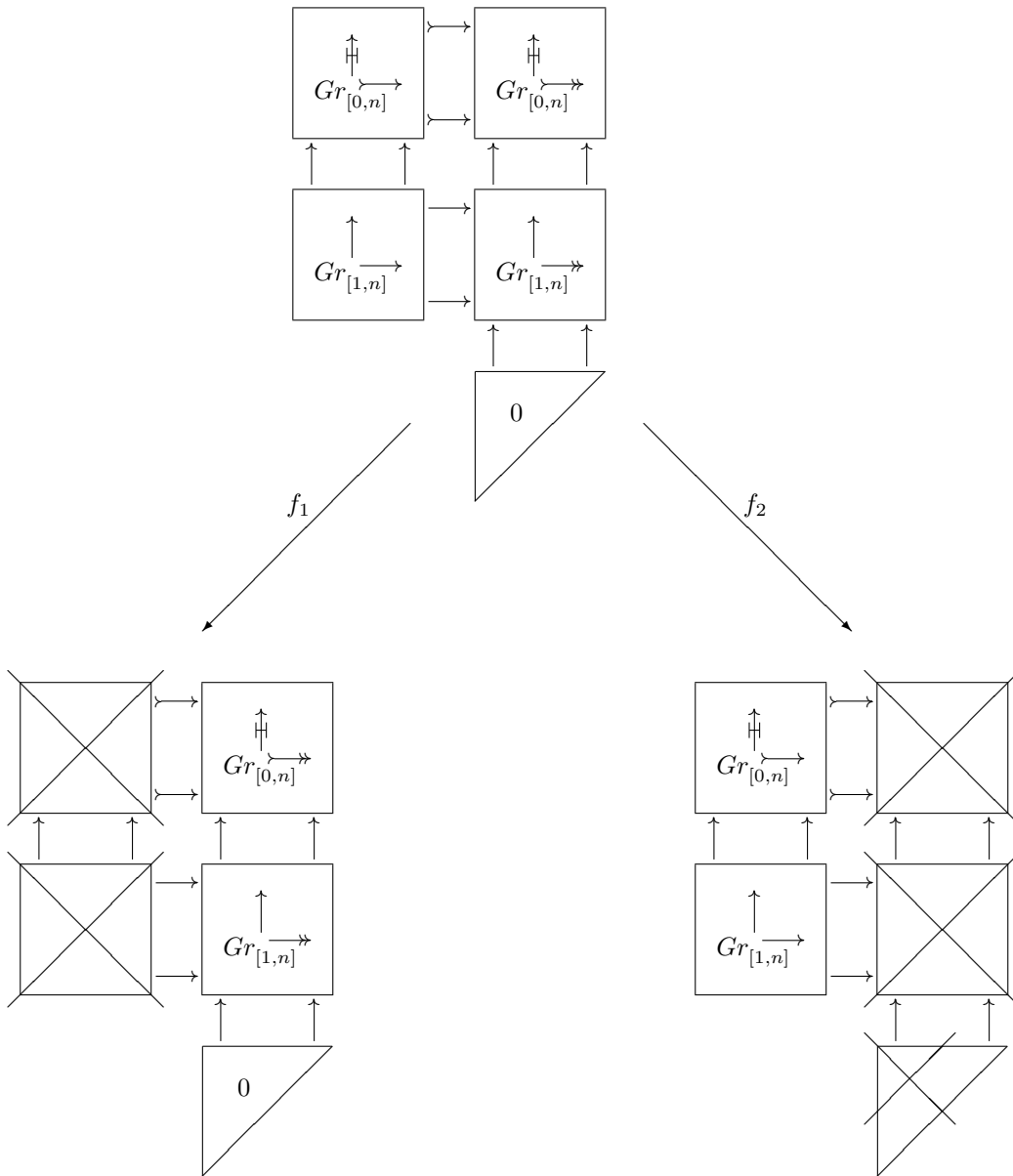

The map f_1 is a homotopy equivalence because on the fiber

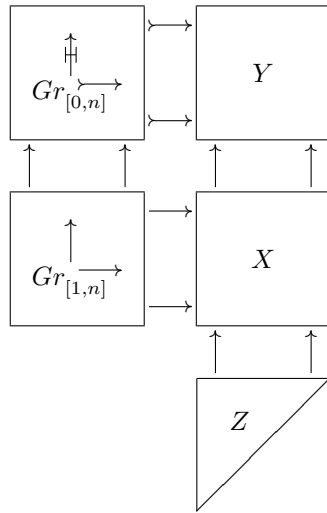

we can apply the contracting homotopy

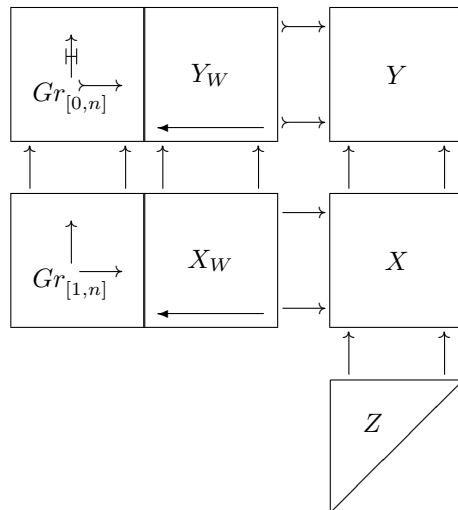

The map f_2 is slightly trickier. Once again, we must resort to our favorite homotopy. The Segal fiber is the simplicial set

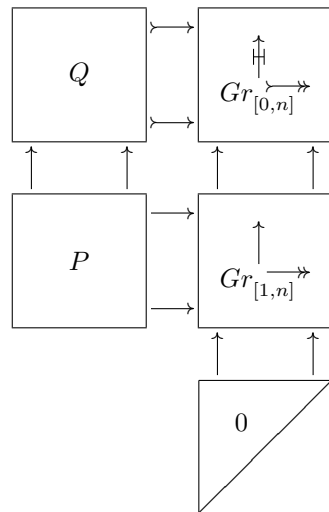

and we need to show it contractible. By the homotopy

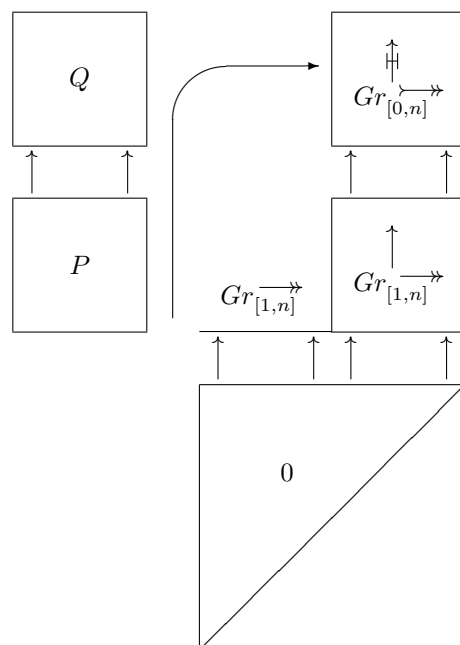

the identity on

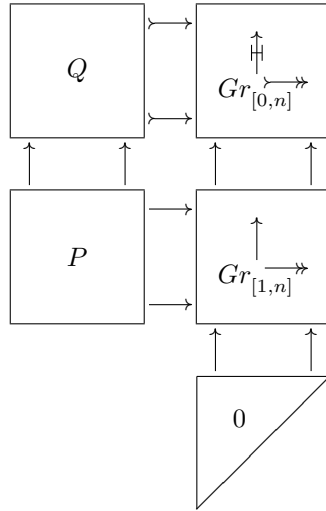

factors through the simplicial set

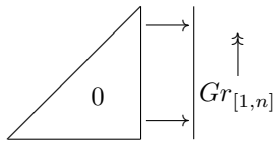

which is trivially contractible, by the contraction to the terminal object. □

REMARK 8.4. Note that as the article progresses, the author feels free to leave more to the reader to check. For instance, the reader should check that the homotopy above is well defined, and does not wander away from its simplicial set of definition. In the original version of the article, verifications of this sort were included in painstaking detail. A number of people objected. The present article attempts to create a notation in which it is clear what the homotopies should be, and they can therefore be left to the reader.

REMARK 8.5. By this time the reader might be getting understandably fidgety about our favorite homotopy. As time goes on, we see more and more variants of it. First we allowed transposes and duals. Then we permitted kernels. Then we allowed ourselves to divide by a fixed subobject. Now we are subdividing the (vertical) simplicial structure. Where will it all end?

The point of Sections II.1 and III.1 is that all the homotopies we have seen, and some more to come, can be obtained by deletion and subdivision from one master homotopy, together with its transpose and duals. This is why Sections II.1 and III.1 were put later rather than earlier in these articles. It is hard to see the point of a master blueprint for the homotopy, unless one has first seen examples.

LEMMA 8.6. *The projection*

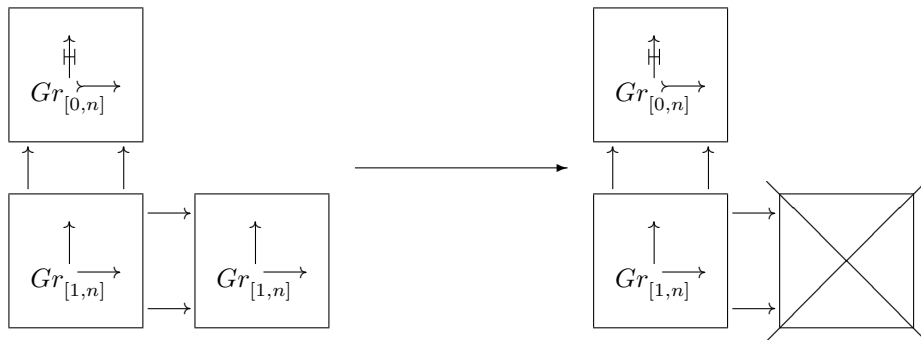

is a homotopy equivalence.

Proof. The Segal fiber is the simplicial set

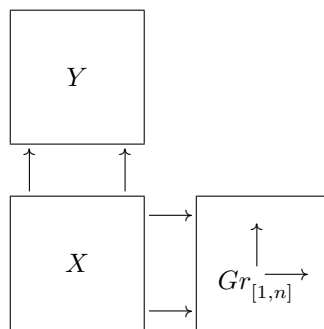

and it is contracted by the homotopy

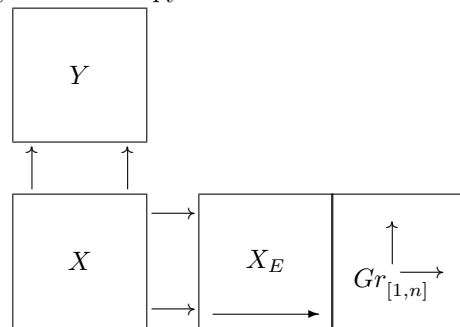

□

LEMMA 8.7. *The projection*

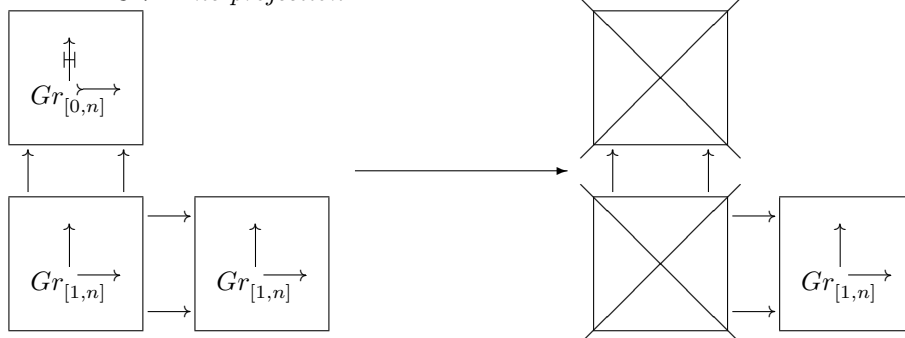

is a quasi-fibration.

Proof. We need to study the fiber

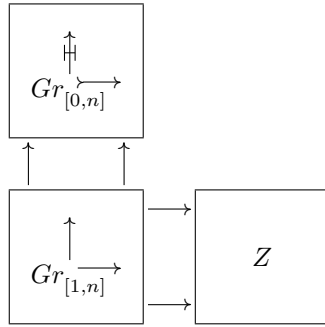

Once again, we apply our very favorite homotopy. Precisely, there is a homotopy

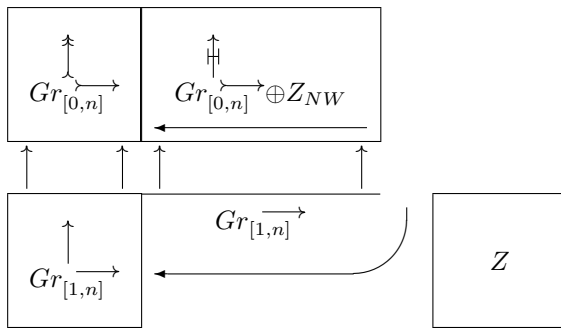

and because this is a slightly new incarnation of our favorite homotopy, we will present its cells. The homotopy takes a cell in

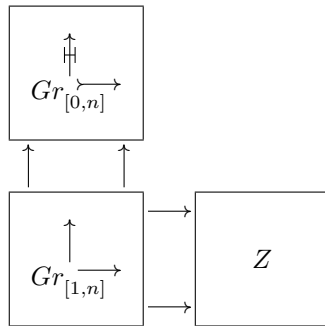

to lots of cells. Precisely, given a (q, r) cell $s_{(q,r)}$ in the bisimplicial set

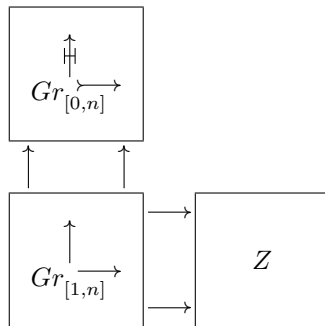

the cell defines a diagram

$$s_{(q,r)} = \left(\begin{array}{ccccccc} Y_{r0} & \xrightarrow{\quad} & \cdots & \xrightarrow{\quad} & Y_{rq} & & \\ \uparrow \text{H} & & & & \uparrow \text{H} & & \\ \vdots & & & & \vdots & & \\ \uparrow \text{H} & & & & \uparrow \text{H} & & \\ Y_{00} & \xrightarrow{\quad} & \cdots & \xrightarrow{\quad} & Y_{0q} & & \\ \uparrow & & & & \uparrow & & \\ X_{p0} & \longrightarrow & \cdots & \longrightarrow & X_{pq} & \longrightarrow & \boxed{Z_{p0} \longrightarrow \cdots \longrightarrow Z_{ps}} \\ \uparrow & & & & \uparrow & & \uparrow \\ \vdots & & & & \vdots & & \vdots \\ \uparrow & & & & \uparrow & & \uparrow \\ X_{00} & \longrightarrow & \cdots & \longrightarrow & X_{0q} & \longrightarrow & \boxed{Z_{00} \longrightarrow \cdots \longrightarrow Z_{0s}} \end{array} \right)$$

The homotopy we will give will be a *horizontal* homotopy. It is defined by cells which increase the integer q , but leave r unchanged. It can be thought of as giving a homotopy first on each horizontal realisation, and these homotopies glue to define a global homotopy when we also realise the simplicial structure that corresponds to varying r .

To our starting cell $s_{(q,r)}$ we must associate $q + 1$ $(q + 1, r)$ cells. The $(q - i)^{th}$ is given by the diagram

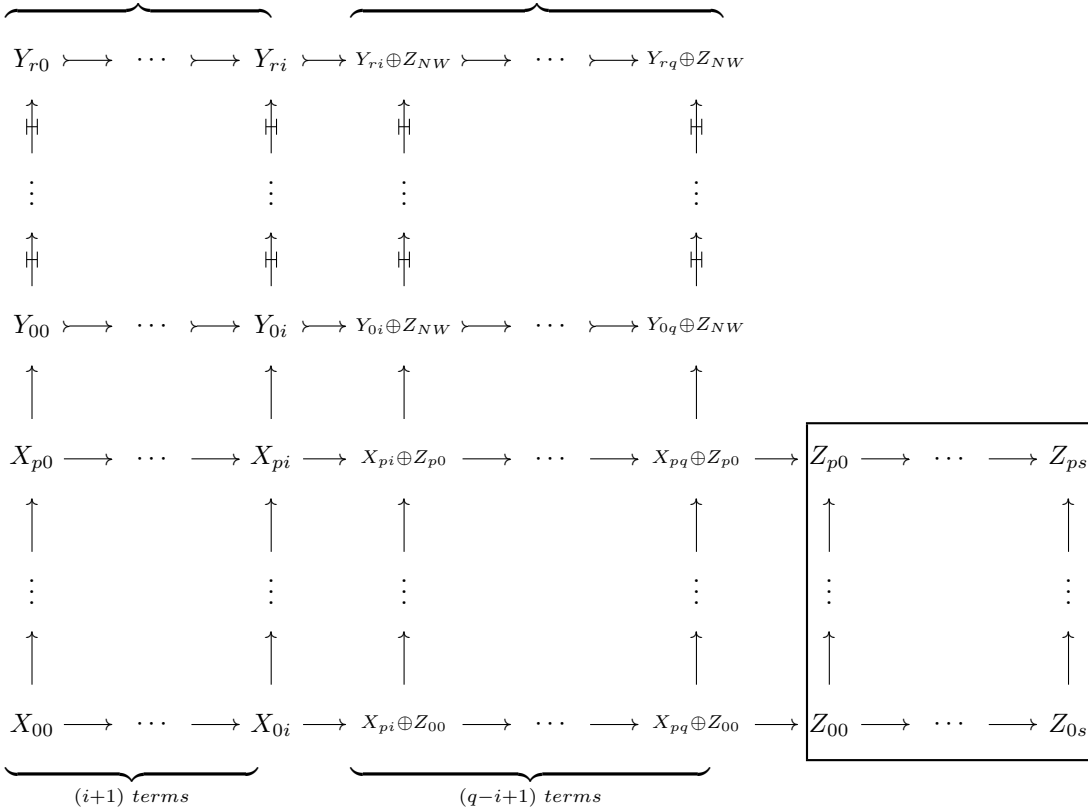

The notation for the homotopy is meant to be self-explanatory. The part enclosed in a dashbox below

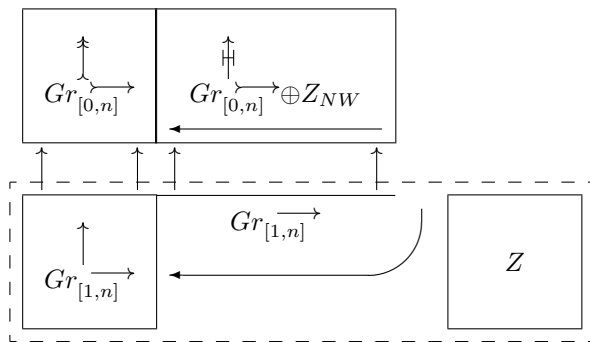

is nothing other than our favorite old homotopy, quite untampered. But what we next enclose in a dashbox represents the fact that in the top right hand box, the homotopy adds a Z_{NW} .

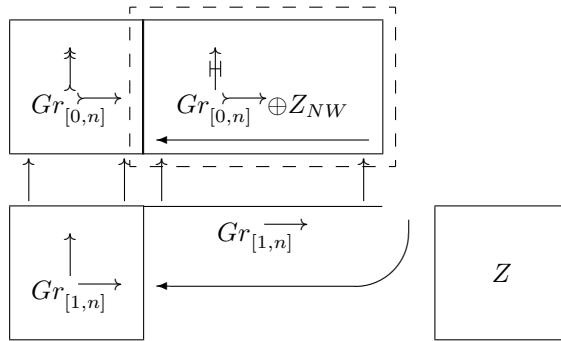

The reader should note that in Proposition 7.9 we have already computed the map

$$X_{pk} \oplus Z_{NW} \xrightarrow{\gamma} Y_{0k} \oplus Z_{NW}.$$

It is the matrix

$$\begin{pmatrix} \alpha & 0 \\ -\beta & 1 \end{pmatrix}$$

where $\alpha : X_{pk} \rightarrow Y_{0k}$ and $\beta : X_{pk} \rightarrow Z_{NW}$ are the natural structural morphisms of the simplex $s_{(q,r)}$. This also is reflected in the notation for the homotopy. The homotopy connects the identity with a map we might naturally call

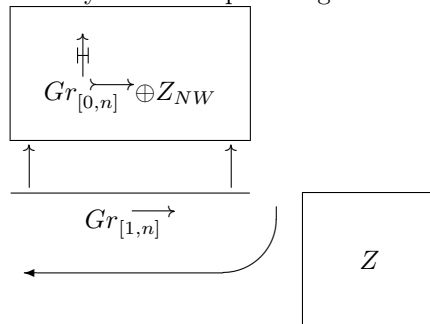

and, as the notation should suggest, this map factors through the simplicial set

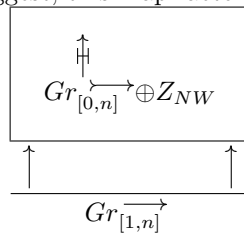

Another way we have been writing this simplicial set is

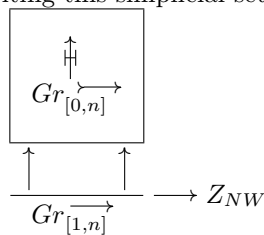

The point is that a simplex in this simplicial set should be thought of as a simplex in

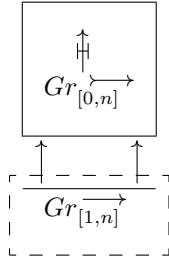

together with a map from the bottom line, which I have conveniently highlighted with a dashbox, to the fixed object Z_{NW} .

This map to Z_{NW} is a nuisance. We want to prove some map a quasifibration, and this means that the homotopy type of the fiber should be independent of Z . We have deduced thus far that the identity on

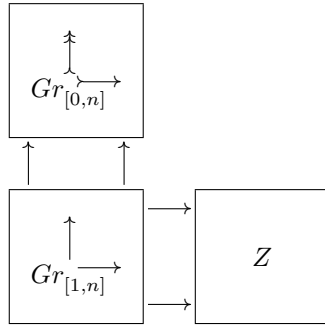

factors up to homotopy through the map

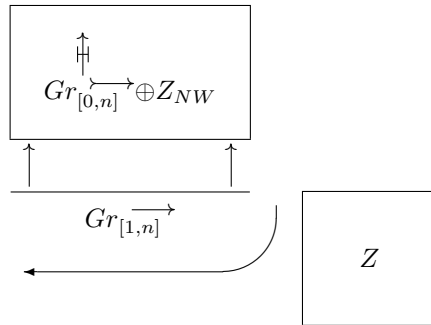

And now we follow by another homotopy, this time vertical, which we denote

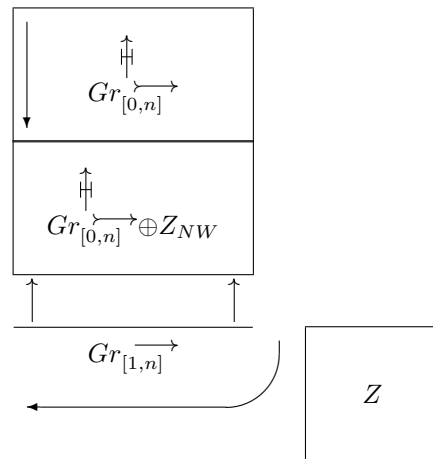

The cells of this homotopy are

$$\left\{ \begin{array}{ccc} Y_{r0} & \xrightarrow{\quad} \cdots \xrightarrow{\quad} & Y_{rq} \\ \uparrow \text{H} & & \uparrow \text{H} \\ \vdots & & \vdots \\ \uparrow \text{H} & & \uparrow \text{H} \\ Y_{i0} & \xrightarrow{\quad} \cdots \xrightarrow{\quad} & Y_{iq} \\ \uparrow \text{H} & & \uparrow \text{H} \end{array} \right\} \left(\begin{array}{c} r-i+1 \\ \text{terms} \end{array} \right)$$

$$\left\{ \begin{array}{ccc} Y_{i0} \oplus Z_{NW} & \xrightarrow{\quad} \cdots \xrightarrow{\quad} & Y_{iq} \oplus Z_{NW} \\ \uparrow \text{H} & & \uparrow \text{H} \\ \vdots & & \vdots \\ \uparrow \text{H} & & \uparrow \text{H} \\ Y_{00} \oplus Z_{NW} & \xrightarrow{\quad} \cdots \xrightarrow{\quad} & Y_{0q} \oplus Z_{NW} \end{array} \right\} \left(\begin{array}{c} i+1 \\ \text{terms} \end{array} \right)$$

$$\begin{array}{ccccccc} & \uparrow & & \uparrow & & & \\ & X_{p0} \oplus Z_{p0} & \longrightarrow & \cdots & \longrightarrow & X_{pq} \oplus Z_{p0} & \longrightarrow \\ & \uparrow & & & & \uparrow & \\ & \vdots & & & & \vdots & \\ & \uparrow & & & & \uparrow & \\ & X_{p0} \oplus Z_{00} & \longrightarrow & \cdots & \longrightarrow & X_{pq} \oplus Z_{00} & \longrightarrow \\ & & & & & & \boxed{ \begin{array}{ccc} Z_{p0} & \longrightarrow & \cdots & \longrightarrow & Z_{ps} \\ \uparrow & & & & \uparrow \\ \vdots & & & & \vdots \\ \uparrow & & & & \uparrow \\ Z_{00} & \longrightarrow & \cdots & \longrightarrow & Z_{0s} \end{array} } \end{array}$$

The last map clearly exhibits that, up to homotopy, the identity on the fiber factors through the bisimplicial set

$$\begin{array}{c} \boxed{ \begin{array}{c} \uparrow \text{H} \\ Gr_{[0,n]} \end{array} } \\ \uparrow \quad \uparrow \\ \hline Gr_{[1,n]} \end{array}$$

And thus we are rid of the nuisance map to Z_{NW} . More precisely, there are maps

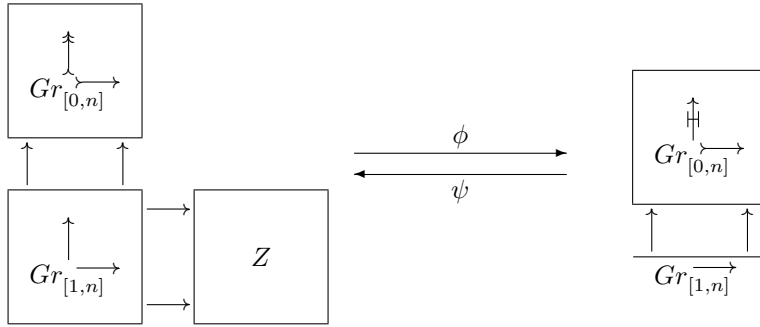

We have just proved that $\psi \circ \phi$ is homotopic to the identity. But one can easily compute $\phi \circ \psi$ and show it to be a translation in the H -space structure of the connected space

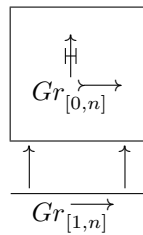

This proves that the homotopy type of the fiber is independent of Z . An easy computation, left to the reader, shows that the face maps are homotopy equivalences. See also the proof of Lemma 7.15. \square

Conclusion of Lemmas 8.1–8.7. What we have done so far is establish, in a somewhat roundabout way, that there is a homotopy equivalence between realizations of

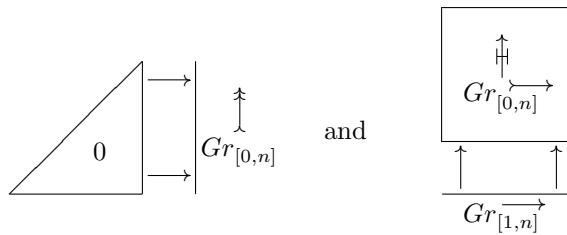

It follows from Lemmas 8.1–8.7 that both are the homotopy fibers of the same map. Now we come to the crux of the matter.

LEMMA 8.8. *The inclusion*

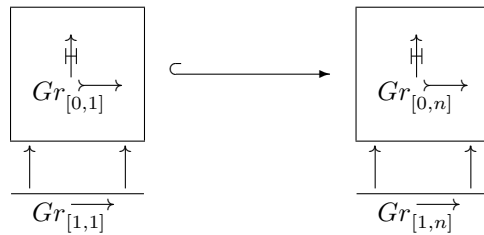

induces a homotopy equivalence.

Proof. We factor the inclusion as the composite

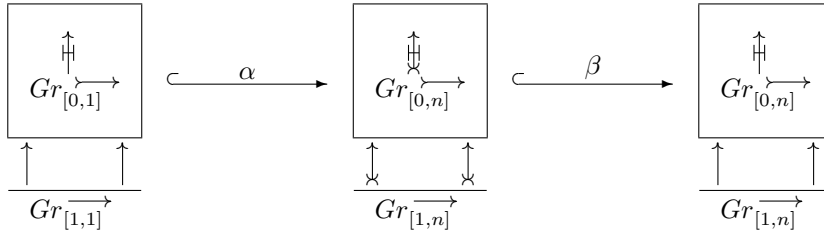

where a morphism $X \rightarrow Y$ in $Gr_{[0,n]}$ is said to be $\varkappa \rightarrow$ if for all $2 \leq i \leq n$, it induces H^i -isomorphisms (of course, a morphism $\varkappa \rightleftarrows$ induces H^i -isomorphisms for $i = 0$ and $2 \leq i \leq n$).

Truncation above dimension 1 clearly gives a homotopy inverse for the map α . The homotopy inverse of the map β is also quite explicit. Take a (p, q) -simplex $y_{(p,q)}$ in

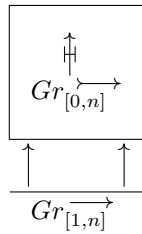

Such a simplex is a diagram

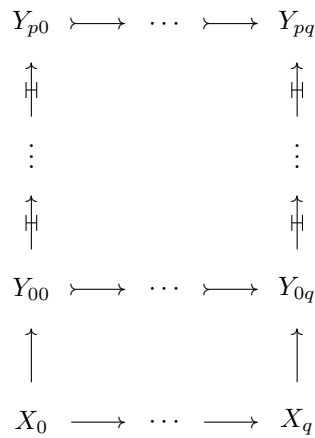

and the homotopy inverse of β sends it to

$$\begin{array}{ccccc}
 Z_{p0} & \xrightarrow{\quad} & \cdots & \xrightarrow{\quad} & Z_{pq} \\
 \uparrow \Downarrow & & & & \uparrow \Downarrow \\
 \vdots & & & & \vdots \\
 \uparrow \Downarrow & & & & \uparrow \Downarrow \\
 Z_{00} & \xrightarrow{\quad} & \cdots & \xrightarrow{\quad} & Z_{0q} \\
 \uparrow \Downarrow & & & & \uparrow \Downarrow \\
 X_0 & \longrightarrow & \cdots & \longrightarrow & X_q
 \end{array}$$

where Z_{ij} is defined as follows:

- 8.8.1. $H^0(Z_{ij}) = H^0(Y_{ij})$
- 8.8.2. $H^k(Z_{ij}) = H^k(X_j)$ for $2 \leq k \leq n$
- 8.8.3. $H^1(Z_{ij}) = \text{Im}(H^1(X_j) \rightarrow H^1(Y_{ij}))$.

The reader will check that the map given above is a bisimplicial map, and that both composites are homotopic to the identity. \square

REMARK 8.9. Perhaps a less mysterious description of this map is as follows. Let F_i be the third edge in the “triangle” $F_i \rightarrow X_j \rightarrow Y_{ij}$. Then Z_{ij} is the third edge of the triangle $H^1(F_i) \rightarrow X_j \rightarrow Z_{ij}$ (note that $F_i \in D_{[1,n+1]}$ in general. There is no epi-ness hypothesis.)

It should also be remarked that the category Gr has this property that one can define on it strange homotopies that do not fall into the simple categories we will discuss in Sections II.1 and III.1. The triangulated proof is harder, but it is also free of “spurious” homotopies.

Up until this point, everything we have done is valid in both Constructions 4.6 and 4.7. The next step is not.

LEMMA 8.10. *The inclusion*

$$\begin{array}{ccc}
 \boxed{\begin{array}{c} \uparrow \Downarrow \\ Gr_{[0,n]} \end{array}} & \hookrightarrow & \boxed{\begin{array}{c} \uparrow \Downarrow \\ Gr_{[0,n+1]} \end{array}} \\
 \uparrow \quad \uparrow & & \uparrow \quad \uparrow \\
 \overline{Gr_{[1,n]}} & & \overline{Gr_{[1,n+1]}}
 \end{array}$$

is null homotopic.

Proof. We leave to the reader the fact that the identification

$$\begin{array}{c}
 \begin{array}{c} \nearrow \\ \text{0} \\ \searrow \end{array} \begin{array}{c} \rightarrow \\ \rightarrow \\ \rightarrow \end{array} \Big| \begin{array}{c} \uparrow \\ \uparrow \\ \uparrow \end{array} \\
 \text{Gr}_{[0,n]}
 \end{array} \simeq \begin{array}{c} \begin{array}{c} \uparrow \\ \uparrow \\ \uparrow \end{array} \\ \text{Gr}_{[0,n]} \end{array} \\
 \begin{array}{c} \leftarrow \\ \leftarrow \\ \leftarrow \end{array} \\
 \text{Gr}_{[1,n]}
 \end{array}$$

is natural in n ; it suffices therefore to show that

$$\begin{array}{c} \nearrow \\ \text{0} \\ \searrow \end{array} \begin{array}{c} \rightarrow \\ \rightarrow \\ \rightarrow \end{array} \Big| \begin{array}{c} \uparrow \\ \uparrow \\ \uparrow \end{array} \text{Gr}_{[0,n]} \hookrightarrow \begin{array}{c} \nearrow \\ \text{0} \\ \searrow \end{array} \begin{array}{c} \rightarrow \\ \rightarrow \\ \rightarrow \end{array} \Big| \begin{array}{c} \uparrow \\ \uparrow \\ \uparrow \end{array} \text{Gr}_{[0,n+1]}$$

is null homotopic. But this inclusion factors as

$$\begin{array}{c} \nearrow \\ \text{0} \\ \searrow \end{array} \begin{array}{c} \rightarrow \\ \rightarrow \\ \rightarrow \end{array} \Big| \begin{array}{c} \uparrow \\ \uparrow \\ \uparrow \end{array} \text{Gr}_{[0,n]} \hookrightarrow \begin{array}{c} \nearrow \\ \text{0} \\ \searrow \end{array} \begin{array}{c} \rightarrow \\ \rightarrow \\ \rightarrow \end{array} \Big| \begin{array}{c} \uparrow \\ \uparrow \\ \uparrow \end{array} \text{Gr}_{[0,n]} \hookrightarrow \begin{array}{c} \nearrow \\ \text{0} \\ \searrow \end{array} \begin{array}{c} \rightarrow \\ \rightarrow \\ \rightarrow \end{array} \Big| \begin{array}{c} \uparrow \\ \uparrow \\ \uparrow \end{array} \text{Gr}_{[0,n+1]}$$

(this is just the fact that any morphism in $\text{Gr}_{[0,n]}$ is epi, when viewed in $\text{Gr}_{[0,n+1]}$).

On the other hand

$$\begin{array}{c} \nearrow \\ \text{0} \\ \searrow \end{array} \begin{array}{c} \rightarrow \\ \rightarrow \\ \rightarrow \end{array} \Big| \begin{array}{c} \uparrow \\ \uparrow \\ \uparrow \end{array} \text{Gr}_{[0,n]} \stackrel{=}{=} \begin{array}{c} \uparrow \\ \uparrow \\ \uparrow \end{array} \begin{array}{c} \rightarrow \\ \rightarrow \\ \rightarrow \end{array} \begin{array}{c} \searrow \\ \text{0} \\ \nearrow \end{array}$$

(because for the symmetric construction, the one where differentials are kept, kernels and cokernels are the same). And the simplicial set on the right is clearly contractible, by the contraction to the initial object. \square

This completes the proof of Theorem 4.8.

Appendix A. Semi-triangles. We remind the reader that this Appendix contains only a sketch of an argument the author never checked carefully. Since the author has forgotten any detail he may have thought about, when he wrote these notes four years ago, he will stick closely to the old notes. It is more probable that they are correct than what he might try to write now.

Let \mathcal{T} be a triangulated category. We define

DEFINITION A.1. In the triangulated category \mathcal{T} , a sequence

$$x \xrightarrow{u} y \xrightarrow{v} z \xrightarrow{w} \Sigma x$$

is called a candidate triangle if the three composites

$$vu, \quad wv, \quad \{\Sigma u\}w$$

all vanish.

DEFINITION A.2. A candidate triangle is called contractible if it is isomorphic to a sum of three trivial candidate triangles

$$\begin{array}{ccccccc}
 x & \xrightarrow{1} & x & \longrightarrow & 0 & \longrightarrow & \Sigma x \\
 0 & \longrightarrow & y & \xrightarrow{1} & y & \longrightarrow & 0 \\
 \Sigma^{-1}z & \longrightarrow & 0 & \longrightarrow & z & \xrightarrow{1} & z
 \end{array}$$

Having defined candidate triangles, and defined which of them we view as contractible, it is now time to define morphisms between them. A morphism of candidate triangles is a commutative diagram

$$\begin{array}{ccccccc}
 x & \xrightarrow{u} & y & \xrightarrow{v} & z & \xrightarrow{w} & \Sigma x \\
 \downarrow f & & \downarrow g & & \downarrow h & & \downarrow \Sigma f \\
 x' & \xrightarrow{u'} & y' & \xrightarrow{v'} & z' & \xrightarrow{w'} & \Sigma x'
 \end{array}$$

With this definition, the collection of candidate triangles forms a category. We denote this category $CT(\mathcal{T})$. Given a morphism of candidate triangles as above, its mapping cone is the diagram

$$\begin{array}{ccccccc}
 \begin{pmatrix} -v & 0 \\ g & u' \end{pmatrix} & & \begin{pmatrix} -w & 0 \\ h & v' \end{pmatrix} & & \begin{pmatrix} -\Sigma u & 0 \\ \Sigma f & w' \end{pmatrix} & & \\
 y \oplus x' & \longrightarrow & z \oplus y' & \longrightarrow & \Sigma x \oplus z' & \longrightarrow & \Sigma y \oplus \Sigma x'
 \end{array}$$

The mapping cone construction takes a morphism in $CT(\mathcal{T})$ to an object of $CT(\mathcal{T})$.

DEFINITION A.3. *The subcategory $ST(\mathcal{T}) \subset CT(\mathcal{T})$ is the smallest full subcategory which*

- A.3.1. *Contains all the distinguished triangles.*
- A.3.2. *Contains the mapping cone on any map of its objects.*
- A.3.3. *If C is a candidate triangle in $ST(\mathcal{T})$, and C is isomorphic to a direct sum $C' \oplus C''$ with C' contractible, then $C'' \in ST(\mathcal{T})$.*

An object of $ST(\mathcal{T})$ will be called a semi-triangle in \mathcal{T} .

REMARK A.4. According to my notes, it should be obvious that any semi-triangle is a direct summand of a good semi-triangle of height n , $n \in \mathbb{Z}$. The semi-triangles of height n are defined inductively, as follows

- A.4.1. *The semi-triangles of height 0 are the distinguished triangles.*
- A.4.2. *A semi-triangle of height $n + 1$ is the mapping cone on a map of candidate triangles $C \rightarrow C'$, where C is a distinguished triangle, and C' is a semi-triangle of height n .*

EXAMPLE A.5. Let \mathcal{A} be an abelian category, $\mathcal{T} = D(\mathcal{A})$ its derived category. Given any short exact sequence in \mathcal{A} , that is a sequence

$$0 \rightarrow x \rightarrow y \rightarrow z \rightarrow 0$$

there is a unique differential making it a triangle; there is a unique morphism $w : z \rightarrow \Sigma x$ so that

$$x \rightarrow y \rightarrow z \xrightarrow{w} \Sigma x$$

is a triangle in \mathcal{T} . We have a morphism of triangles

$$\begin{array}{ccccccc}
 \Sigma^{-1}z & \xrightarrow{-\Sigma^{-1}w} & x & \xrightarrow{-u} & y & \xrightarrow{-v} & z \\
 \downarrow \Sigma^{-1}w & & \downarrow 0 & & \downarrow 0 & & \downarrow w \\
 x & \xrightarrow{u} & y & \xrightarrow{v} & z & \xrightarrow{w} & \Sigma x
 \end{array}$$

and the mapping cone is

$$\begin{array}{ccccccc}
 \begin{pmatrix} u & 0 \\ 0 & u \end{pmatrix} & & \begin{pmatrix} v & 0 \\ 0 & v \end{pmatrix} & & \begin{pmatrix} w & 0 \\ w & w \end{pmatrix} & & \\
 x \oplus x & \longrightarrow & y \oplus y & \longrightarrow & z \oplus z & \longrightarrow & \Sigma x \oplus \Sigma x \quad .
 \end{array}$$

This is a semi-triangle, being the mapping cone on a map of triangles. However, it is not in general a distinguished triangle. The sequence

$$\begin{array}{ccccccc}
 & & \begin{pmatrix} u & 0 \\ 0 & u \end{pmatrix} & & \begin{pmatrix} v & 0 \\ 0 & v \end{pmatrix} & & \\
 0 & \longrightarrow & x \oplus x & \longrightarrow & y \oplus y & \longrightarrow & z \oplus z \longrightarrow 0
 \end{array}$$

is a short exact sequence in the abelian category $\mathcal{A} \subset D(\mathcal{A}) = \mathcal{T}$. The unique way to extend it to a triangle is as

$$\begin{array}{ccccccc}
 \begin{pmatrix} u & 0 \\ 0 & u \end{pmatrix} & & \begin{pmatrix} v & 0 \\ 0 & v \end{pmatrix} & & \begin{pmatrix} w & 0 \\ 0 & w \end{pmatrix} & & \\
 x \oplus x & \longrightarrow & y \oplus y & \longrightarrow & z \oplus z & \longrightarrow & \Sigma x \oplus \Sigma x \quad .
 \end{array}$$

But the matrices

$$\begin{pmatrix} w & 0 \\ 0 & w \end{pmatrix} \quad \begin{pmatrix} w & 0 \\ w & w \end{pmatrix}$$

will agree only if $w = 0$. In other words, the semi-triangle above is a triangle precisely if $w = 0$, that is precisely if the short exact sequence

$$0 \longrightarrow x \longrightarrow y \longrightarrow z \longrightarrow 0$$

is split.

DEFINITION A.6. *Let \mathcal{T} be a triangulated category. The simplicial set*

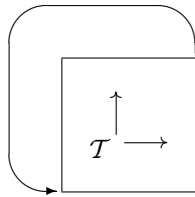

is defined as follows. The (p, q) -simplices are diagrams in \mathcal{T}

$$\begin{array}{ccccccc}
 X_{p0} & \longrightarrow & \cdots & \longrightarrow & X_{pq} & & \\
 \uparrow & & & & \uparrow & & \\
 \vdots & & & & \vdots & & \\
 \uparrow & & & & \uparrow & & \\
 X_{00} & \longrightarrow & \cdots & \longrightarrow & X_{0q} & &
 \end{array}$$

together with a coherent differential $d : X_{pq} \rightarrow \Sigma X_{00}$. Here, a coherent differential $d : X_{pq} \rightarrow \Sigma X_{00}$ is a map such that for any $0 \leq i \leq i' \leq p$, $0 \leq j \leq j' \leq q$,

$$X_{ij} \rightarrow X_{i'j} \oplus X_{ij'} \rightarrow X_{i'j'} \xrightarrow{\phi} \Sigma X_{ij}$$

is a semi-triangle, as in Definition A.3.

We wish to prove Theorem 7.1. The idea is that the proof is the same as the arguments we have been seeing in this article. To do this, we need first define the

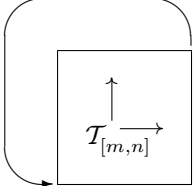
simplicial sets , for any integers $m \leq n$. The definition is as follows

DEFINITION A.7. Let \mathcal{T} be a triangulated category with a t -structure. Let $m \leq n$ be integers. The simplicial set

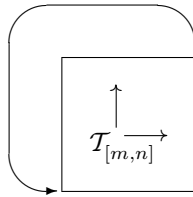

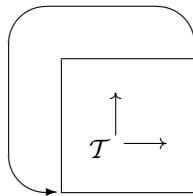
is a subset of . Its simplices are defined as follows. The (p, q) -simplices are diagrams in $\mathcal{T}_{[m,n]}$

$$\begin{array}{ccccc} X_{p0} & \longrightarrow & \cdots & \longrightarrow & X_{pq} \\ \uparrow & & & & \uparrow \\ \vdots & & & & \vdots \\ \uparrow & & & & \uparrow \\ X_{00} & \longrightarrow & \cdots & \longrightarrow & X_{0q} \end{array}$$

together with a coherent differential $d : X_{pq} \rightarrow \Sigma X_{00}$. As in Definition A.6, a coherent differential $d : X_{pq} \rightarrow \Sigma X_{00}$ is a map such that for any $0 \leq i \leq i' \leq p$, $0 \leq j \leq j' \leq q$,

$$X_{ij} \rightarrow X_{i'j} \oplus X_{ij'} \rightarrow X_{i'j'} \xrightarrow{\phi} \Sigma X_{ij}$$

is a semi-triangle, as in Definition A.3. This means that it is a direct summand of an extension of triangles, as in Remark A.4. We require that the other summand can

be chosen to be a (contractible triangle)

$$Z \rightarrow Z' \rightarrow Z'' \xrightarrow{\phi} \Sigma Z$$

with Z, Z' and Z'' in $\mathcal{T}_{[m,n]}$.

Now with the obvious extensions to more elaborate simplicial sets, we can extend the constructions we have seen so far, as well as the constructions in Parts II and III of this article. My notes tell me that the following Lemma is useful in showing that the homotopies that arise are all well-defined

LEMMA A.8. Suppose we are given a simplex in

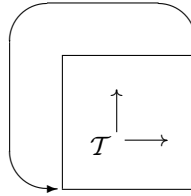

$$\begin{array}{ccccc} Y & \longrightarrow & Y' & \longrightarrow & Y'' \\ \uparrow & & \uparrow & & \uparrow \\ X & \longrightarrow & X' & \longrightarrow & X'' \end{array}$$

and suppose that the two faces of this simplex

$$\begin{array}{ccc} Y & \longrightarrow & Y' \\ \uparrow & & \uparrow \\ X & \longrightarrow & X' \end{array} \quad , \quad \begin{array}{ccc} Y' & \longrightarrow & Y'' \\ \uparrow & & \uparrow \\ X' & \longrightarrow & X'' \end{array}$$

lie in the smaller simplicial set

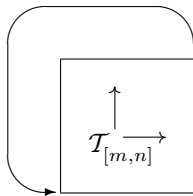

. Then the entire simplex lies in the

smaller simplicial set.

Proof. As part of the structure of a simplex in

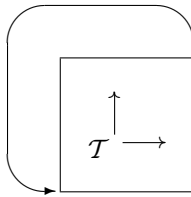

, the diagram

$$\begin{array}{ccccc}
 Y & \longrightarrow & Y' & \longrightarrow & Y'' \\
 \uparrow & & \uparrow & & \uparrow \\
 X & \longrightarrow & X' & \longrightarrow & X''
 \end{array}$$

comes with a coherent differential. This gives us a composite of maps in $CT(\mathcal{T})$

$$\begin{array}{ccccccc}
 X & \longrightarrow & X' \oplus Y & \longrightarrow & Y' & \longrightarrow & \Sigma X \\
 \downarrow & & \downarrow & & \downarrow & & \downarrow \\
 X & \longrightarrow & X'' \oplus Y & \longrightarrow & Y'' & \longrightarrow & \Sigma X \\
 \downarrow & & \downarrow & & \downarrow & & \downarrow \\
 X' & \longrightarrow & X'' \oplus Y' & \longrightarrow & Y'' & \longrightarrow & \Sigma X'
 \end{array}$$

and it is easy to show that the middle row is a direct summand on the mapping cone of an obvious map from the bottom row to a shift of the top. By hypothesis, the top and bottom row are direct summands of extensions of triangles in $\mathcal{T}_{[m,n]}$. Hence so is the middle row. The other summand can be chosen to be contractible, and the objects lie in $\mathcal{T}_{[m,n]}$. This means that the middle row also satisfies the hypothesis of

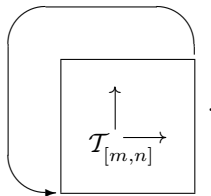
membership in the simplicial set . □

REMARK A.9. At this point, my notes are singularly unhelpful. They assert that, with the simplicial sets as defined above, the proof of Theorem 7.1 goes through; this needs checking, and nothing is said about the details. Anyway, the assertion is that, if the t -structure on \mathcal{T} is non-degenerate, then the natural inclusion

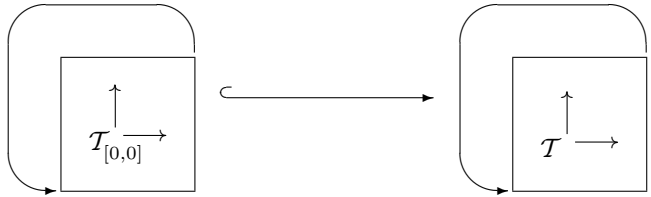

induces a homotopy equivalence.

Let us grant the assertion of Remark A.9. We are still not done. The point is

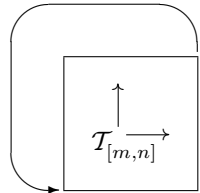
that the simplicial set  is not isomorphic to Quillen's construction

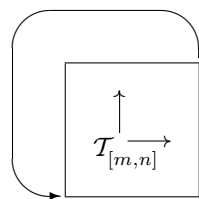
on the abelian category $\mathcal{T}_{[0,0]}$. A simplex in  is a diagram

$$\begin{array}{ccccc}
 X_{p0} & \longrightarrow & \cdots & \longrightarrow & X_{pq} \\
 \uparrow & & & & \uparrow \\
 \vdots & & & & \vdots \\
 \uparrow & & & & \uparrow \\
 X_{00} & \longrightarrow & \cdots & \longrightarrow & X_{0q}
 \end{array}$$

together with the choice of a differential. The assertion that all the X_{ij} 's lie in the heart $\mathcal{T}_{[0,0]}$ does mean that, if we forget the differential, we have a diagram of bicartesian squares. But now all we know is that the differentials give us semi-triangles, not necessarily distinguished triangles. As long as the triangles were distinguished, the differentials were unique. But once we allow semi-triangles, it is sometimes possible to complete the diagram of bicartesian squares

$$\begin{array}{ccccc}
 X_{p0} & \longrightarrow & \cdots & \longrightarrow & X_{pq} \\
 \uparrow & & & & \uparrow \\
 \vdots & & & & \vdots \\
 \uparrow & & & & \uparrow \\
 X_{00} & \longrightarrow & \cdots & \longrightarrow & X_{0q}
 \end{array}$$

to a simplex in more than one way. There may be more than one choice of differentials. See Example A.5 for a concrete illustration of how this can happen.

To rephrase our problem another way, by Remark A.9 the simplicial map

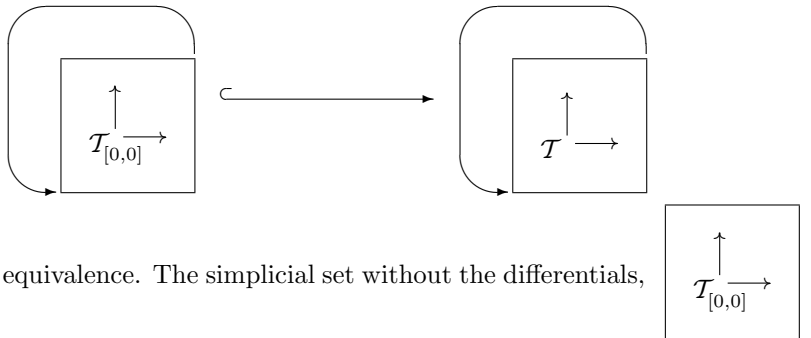

is a homotopy equivalence. The simplicial set without the differentials,

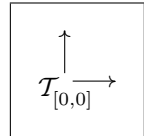

is homotopy equivalent to Quillen's Q -construction. There is a natural map

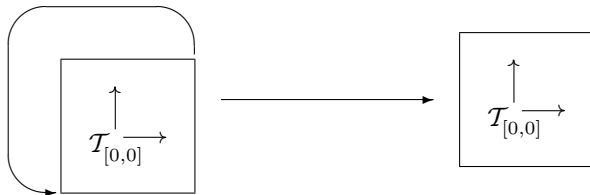

which forgets the differential. Since the differential is non-unique, this map is not an isomorphism. This is our problem. What we need to see is that the map forgetting the differentials, although not an isomorphism, is still a homotopy equivalence. Here, fortunately, my old notes are more helpful.

REMARK A.10. Before we proceed with the notes I wrote years ago, let me

make a comment. It is already clear that the simplicial set

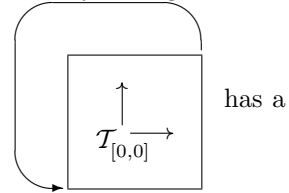

has a

homotopy type independent of the category \mathcal{T} , and depending only on the heart $\mathcal{T}_{[0,0]}$. After all, a simplex involves only objects $X_{ij} \in \mathcal{T}_{[0,0]}$, morphisms $X_{ij} \rightarrow X_{i'j'}$, and differentials $X_{ij} \rightarrow \Sigma X_{i'j'}$, that is extensions of X_{ij} by $X_{i'j'}$. This data is completely determined by the abelian category $\mathcal{T}_{[0,0]}$.

It follows that the homotopy type of the simplicial set

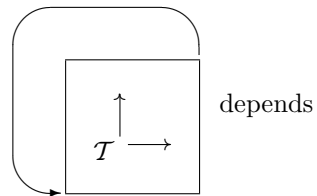

depends

only on the heart $\mathcal{T}_{[0,0]}$, and therefore agrees, for example, with the homotopy type in the special case $\mathcal{T} = D(\mathcal{T}_{[0,0]})$, that is the derived category of the heart.

We return to the notes. From now through the rest of this Appendix, all simplicial sets will be assumed to come with coherent differentials. When we write the

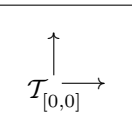
symbol , we will really mean what we have, until now, been denoting

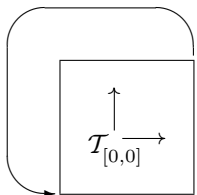
. We will only explicitly write the symbol for the differential in

the shorthand for the simplicial set when we want to indicate that the differential is restricted. Thus, the symbol

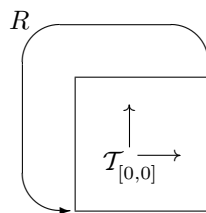

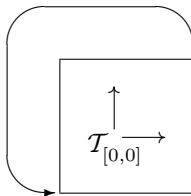
will stand for the simplicial subset of , where the differential yields

not any semi-triangles, but distinguished triangles. Since this makes the differentials unique, this simplicial set is isomorphic to the one without the differentials; that is, it is homotopy equivalent to Quillen's Q -construction.

We wish to show the inclusion

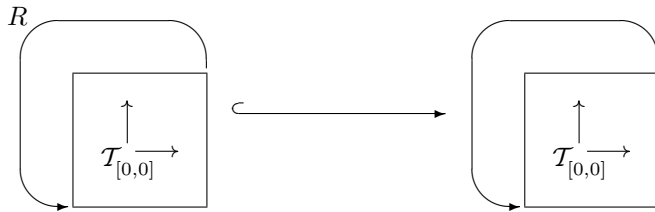

a homotopy equivalence. The idea is to study

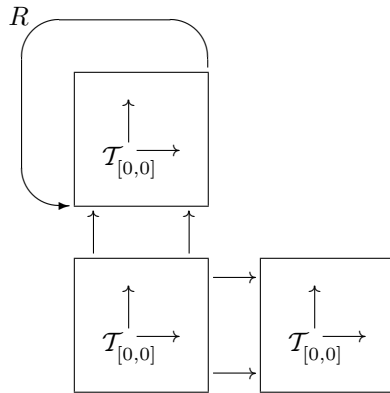

Recall that this means a simplicial set with differentials, and the differentials in the top square are restricted. The restricted differentials yield distinguished triangles, not only semi-triangles. We have

LEMMA A.11. *The natural projection*

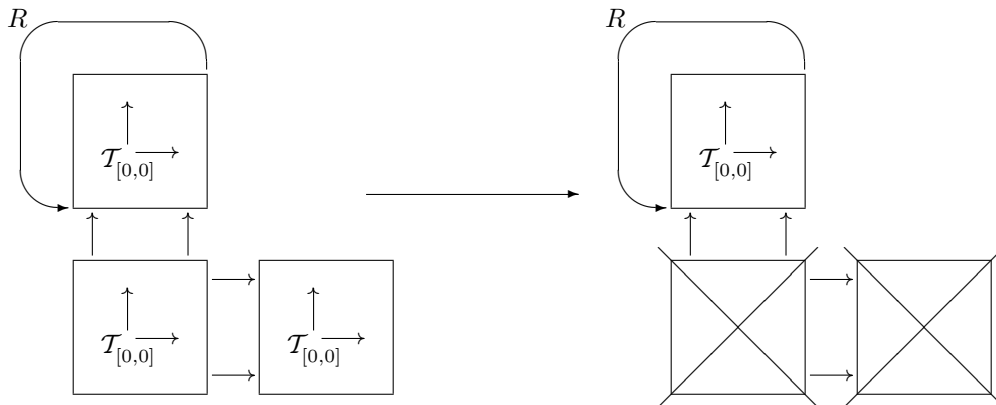

induces a homotopy equivalence.

Proof. Trivial. □

LEMMA A.12. *The natural projection*

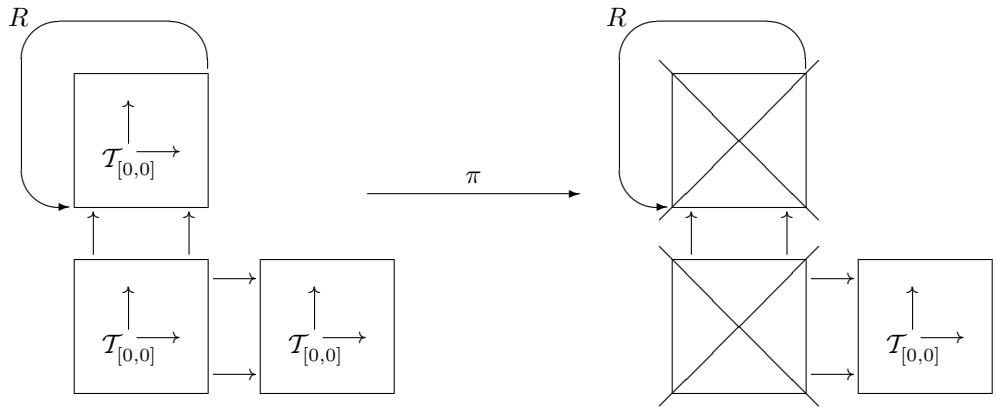

is a quasifibration, having the simplicial set

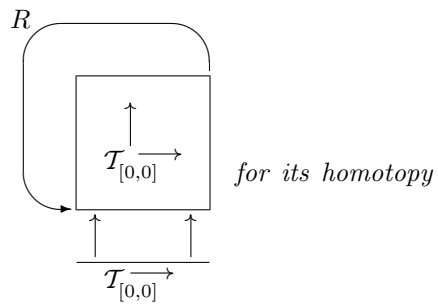

fiber.

Proof. The Segal fiber of the map π is the simplicial set

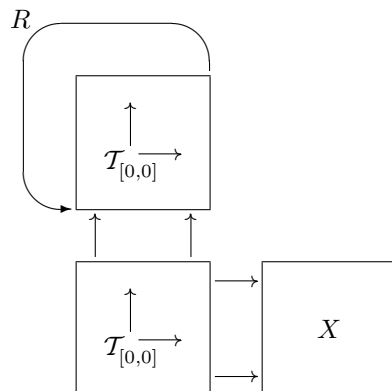

The homotopies

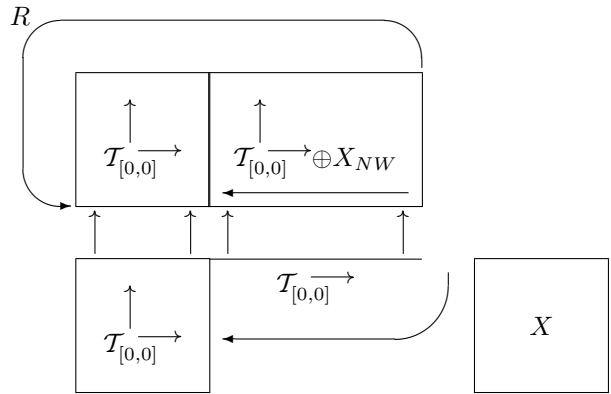

followed by

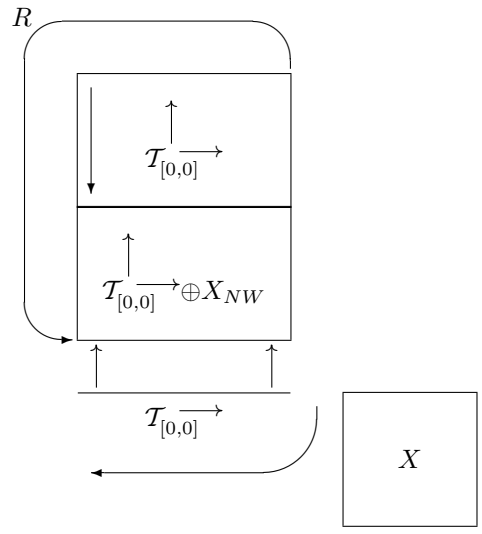

allow the identity on the Segal fiber to factor through

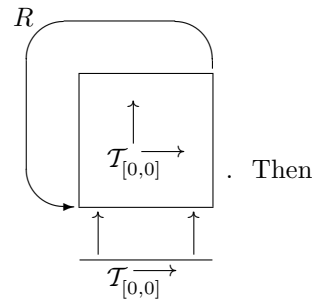

one easily shows this factorisation is a homotopy equivalence, and that the face maps in X induce homotopy equivalences on the Segal fibers. \square

Now we want to study the simplicial set that the author finds difficult to write down. By rights, in keeping with our conventions, its symbol should be

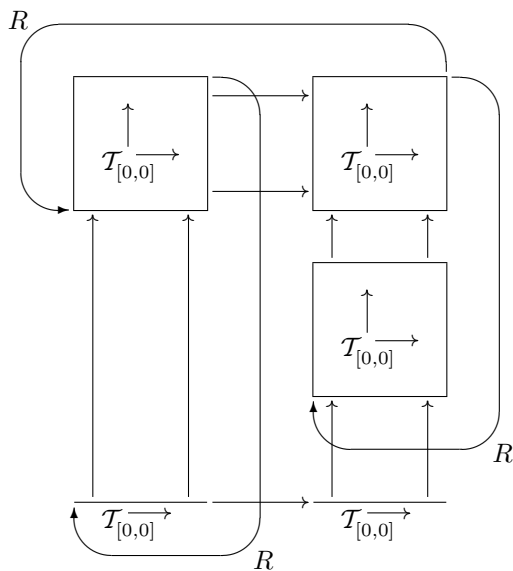

In other words, all the differentials are restricted, except the ones involving the line on the left. We have a string of easy lemmas.

LEMMA A.13. *The natural projection*

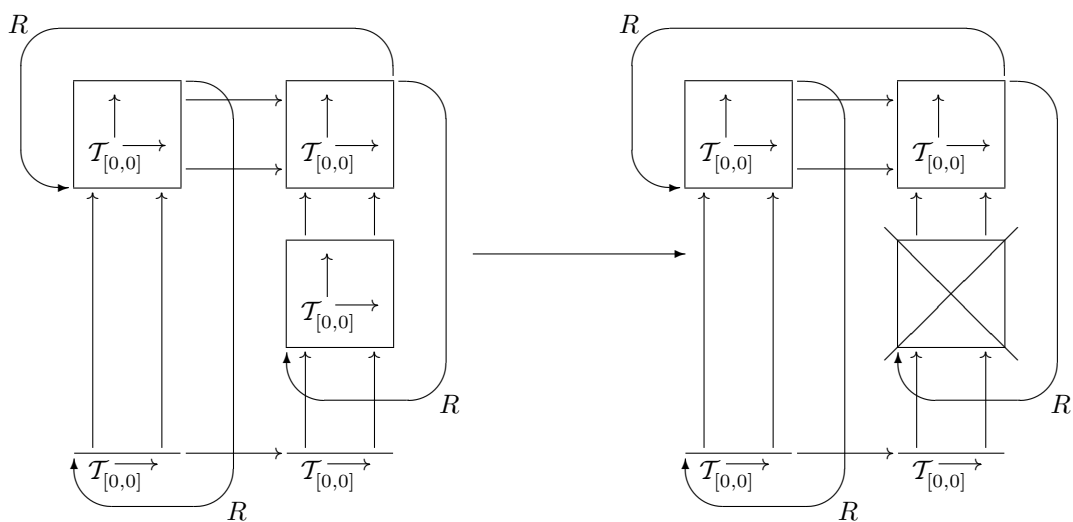

induces a homotopy equivalence.

Proof. The Segal fiber is contracted by the homotopy

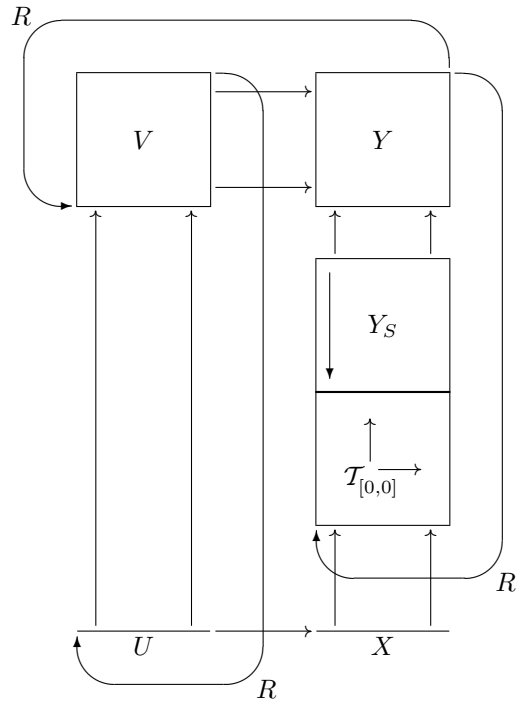

□

LEMMA A.14. *The natural projection*

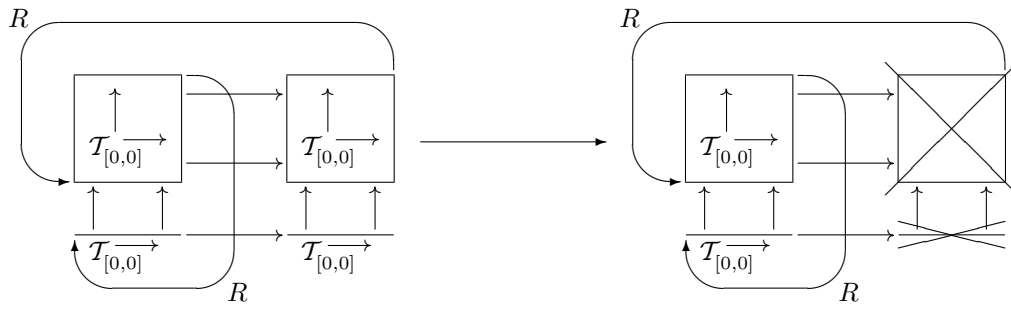

induces a homotopy equivalence.

Proof. The Segal fiber is contracted by the homotopy

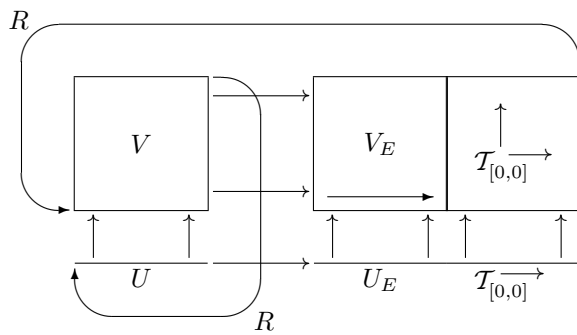

□

LEMMA A.15. *The simplicial set*

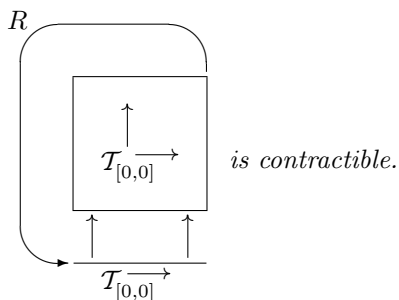

is contractible.

Proof. Trivial. □

Lemmas A.13, A.14 and A.15 combine to show that the simplicial set

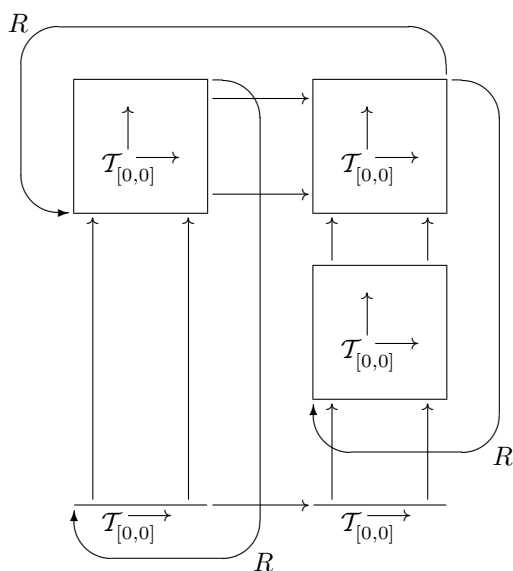

is contractible. It therefore suffices to show that the natural projection

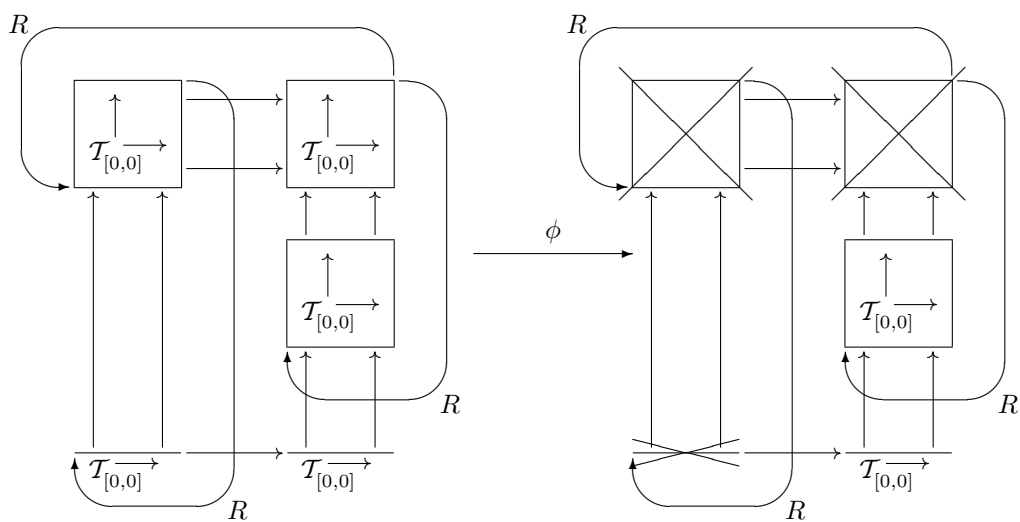

induces a homotopy equivalence. After all, it is a map from a contractible set to the homotopy fiber we want to show contractible.

So we will now proceed to study the Segal fiber of the map ϕ . The Segal fiber is the simplicial set

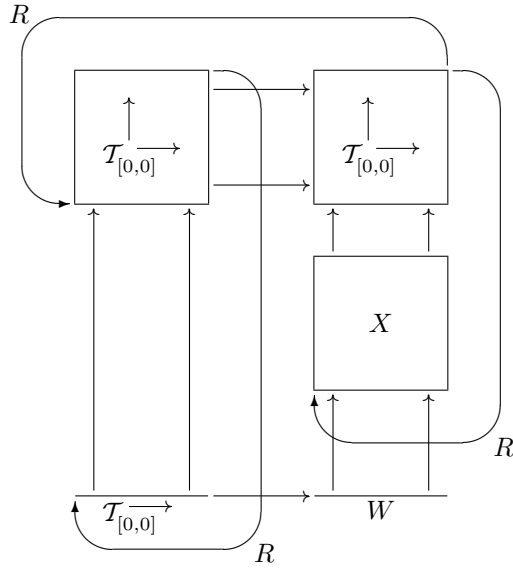

Now, the homotopy

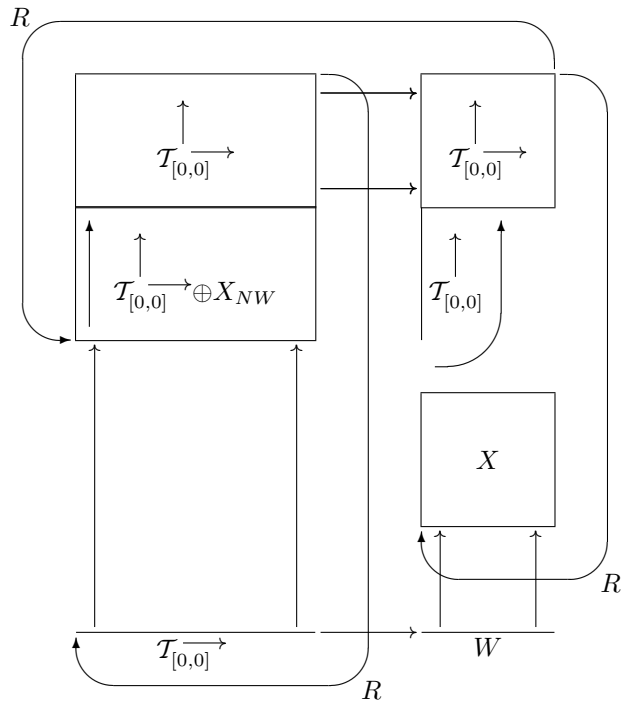

may be followed by a homotopy

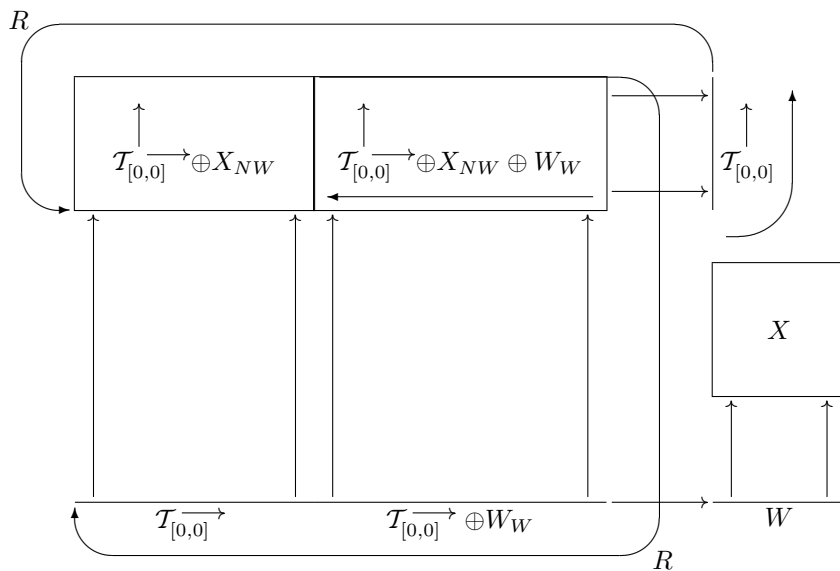

and the point is that the two homotopies combine to factor the identity on the Segal

fiber of ϕ through a space that depends little on the fixed data

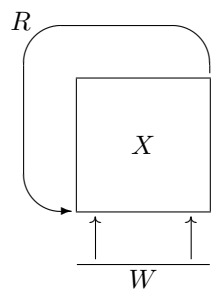

The fixed data in particular gives us a $(0,1)$ -cell

$$\begin{array}{ccc}
 X_{NW} & \longrightarrow & X_{NE} \\
 \uparrow & & \uparrow \\
 W_W & \longrightarrow & W_E
 \end{array}$$

The identity on the Segal fiber of ϕ factors, up to homotopy, through a simplicial set we will denote

$$\left(\begin{array}{ccc} X_{NW} & \longrightarrow & X_{NE} \\ \uparrow & & \uparrow \\ W_W & \longrightarrow & W_E \end{array} \right) \longrightarrow \left(\begin{array}{c} R \\ \begin{array}{ccc} \begin{array}{ccc} \mathcal{T}_{[0,0]} & \longrightarrow & \mathcal{T}_{[0,0]} \\ \uparrow & & \uparrow \\ \mathcal{T}_{[0,0]} & \longrightarrow & 0 \end{array} \\ \uparrow & \uparrow & \uparrow \\ \mathcal{T}_{[0,0]} & \longrightarrow & 0 \end{array} \\ R \end{array} \right)$$

and I owe the reader a definition of what this means.

A simplex in

$$\left(\begin{array}{c} R \\ \begin{array}{ccc} \begin{array}{ccc} \mathcal{T}_{[0,0]} & \longrightarrow & \mathcal{T}_{[0,0]} \\ \uparrow & & \uparrow \\ \mathcal{T}_{[0,0]} & \longrightarrow & 0 \end{array} \\ \uparrow & \uparrow & \uparrow \\ \mathcal{T}_{[0,0]} & \longrightarrow & 0 \end{array} \\ R \end{array} \right)$$

is a diagram

$$\begin{array}{ccccccc} V_{p0} & \longrightarrow & \cdots & \longrightarrow & V_{pq} & \longrightarrow & Y_p \\ \uparrow & & & & \uparrow & & \uparrow \\ \vdots & & & & \vdots & & \vdots \\ \uparrow & & & & \uparrow & & \uparrow \\ V_{00} & \longrightarrow & \cdots & \longrightarrow & V_{0q} & \longrightarrow & Y_0 \\ \uparrow & & & & \uparrow & & \uparrow \\ U_0 & \longrightarrow & \cdots & \longrightarrow & U_q & \longrightarrow & 0 \end{array}$$

$W_E \rightarrow Y_i$ to be zero, this gives maps

$$\left(\begin{array}{ccc} X_{NW} & \longrightarrow & X_{NE} \\ \uparrow & & \uparrow \\ W_W & \longrightarrow & W_E \end{array} \right) \longrightarrow \left(\begin{array}{c} R \\ \begin{array}{ccc} \begin{array}{ccc} \uparrow & & \uparrow \\ \mathcal{T}_{[0,0]} & \longrightarrow & \mathcal{T}_{[0,0]} \\ \uparrow & & \uparrow \\ \mathcal{T}_{[0,0]} & \longrightarrow & 0 \end{array} \\ \uparrow & & \uparrow \\ \mathcal{T}_{[0,0]} & \longrightarrow & 0 \end{array} \\ R \end{array} \right)$$

and we require that they commute with all the structure maps. The reader is asked to verify that the identity on the Segal fiber factors up to homotopy as we said.

It suffices therefore to prove the contractibility of the simplicial set

$$\left(\begin{array}{ccc} X_{NW} & \longrightarrow & X_{NE} \\ \uparrow & & \uparrow \\ W_W & \longrightarrow & W_E \end{array} \right) \longrightarrow \left(\begin{array}{c} R \\ \begin{array}{ccc} \begin{array}{ccc} \uparrow & & \uparrow \\ \mathcal{T}_{[0,0]} & \longrightarrow & \mathcal{T}_{[0,0]} \\ \uparrow & & \uparrow \\ \mathcal{T}_{[0,0]} & \longrightarrow & 0 \end{array} \\ \uparrow & & \uparrow \\ \mathcal{T}_{[0,0]} & \longrightarrow & 0 \end{array} \\ R \end{array} \right)$$

The next point is to reduce to the contractibility in the special case where the simplex

$$\begin{array}{ccc} X_{NW} & \longrightarrow & X_{NE} \\ \uparrow & & \uparrow \\ W_W & \longrightarrow & W_E \end{array}$$

vanishes. The argument is as in the proof of Lemma 7.11. The simplicial set

$$\left(\begin{array}{ccc} X_{NW} & \longrightarrow & X_{NE} \\ \uparrow & & \uparrow \\ W_W & \longrightarrow & W_E \end{array} \right) \longrightarrow \left(\begin{array}{c} R \\ \begin{array}{c} \begin{array}{c} \begin{array}{c} \begin{array}{c} \mathcal{T}_{[0,0]} \end{array} \\ \uparrow \\ \mathcal{T}_{[0,0]} \end{array} \\ \begin{array}{c} \begin{array}{c} \mathcal{T}_{[0,0]} \end{array} \\ \uparrow \\ 0 \end{array} \end{array} \end{array} \end{array} \right)$$

has a fake H -space action, as well as an action by the true H -space

$$\left(\begin{array}{ccc} 0 & \longrightarrow & 0 \\ \uparrow & & \uparrow \\ 0 & \longrightarrow & 0 \end{array} \right) \longrightarrow \left(\begin{array}{c} R \\ \begin{array}{c} \begin{array}{c} \begin{array}{c} \begin{array}{c} \mathcal{T}_{[0,0]} \end{array} \\ \uparrow \\ \mathcal{T}_{[0,0]} \end{array} \\ \begin{array}{c} \begin{array}{c} \mathcal{T}_{[0,0]} \end{array} \\ \uparrow \\ 0 \end{array} \end{array} \end{array} \right)$$

Playing off the two actions exactly as in the proof of Lemma 7.11, one proves that the contractibility of the simplicial set

$$\left(\begin{array}{ccc} 0 & \longrightarrow & 0 \\ \uparrow & & \uparrow \\ 0 & \longrightarrow & 0 \end{array} \right) \longrightarrow \left(\begin{array}{c} R \\ \begin{array}{c} \begin{array}{c} \begin{array}{c} \begin{array}{c} \mathcal{T}_{[0,0]} \end{array} \\ \uparrow \\ \mathcal{T}_{[0,0]} \end{array} \\ \begin{array}{c} \begin{array}{c} \mathcal{T}_{[0,0]} \end{array} \\ \uparrow \\ 0 \end{array} \end{array} \end{array} \right)$$

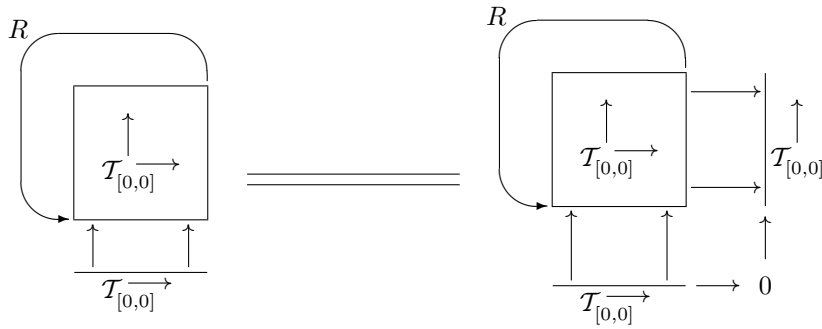

is $(n + 1)$ -connected.

In other words, if we could show that the natural inclusion

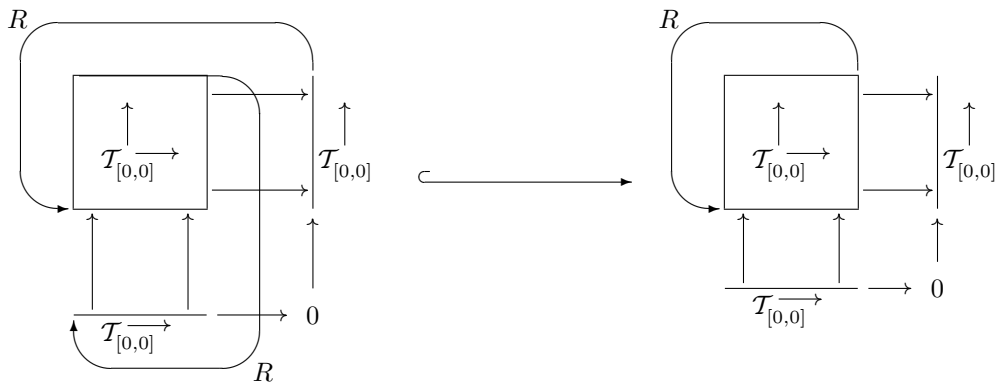

is a homotopy equivalence, we would be done. By Remark A.16 we know that if

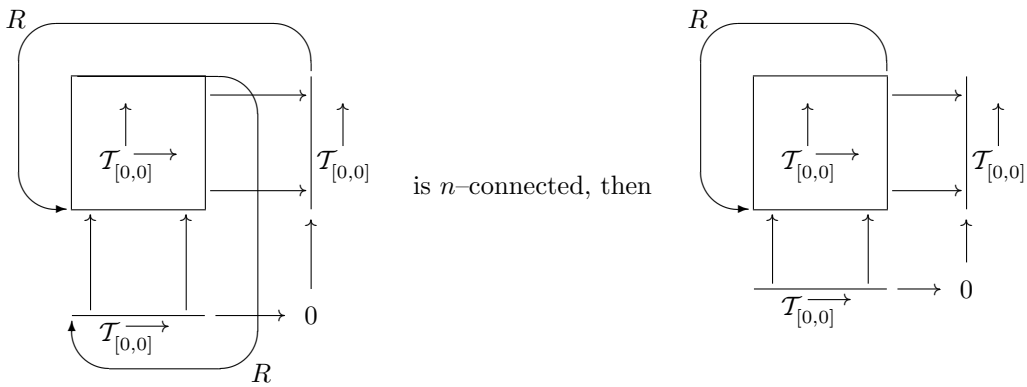

is $(n + 1)$ -connected. If the inclusion is a homotopy equivalence, then both sets are contractible.

REMARK A.17. This is where my notes stop. I have no recollection what idea, if any, I had for proving the inclusion

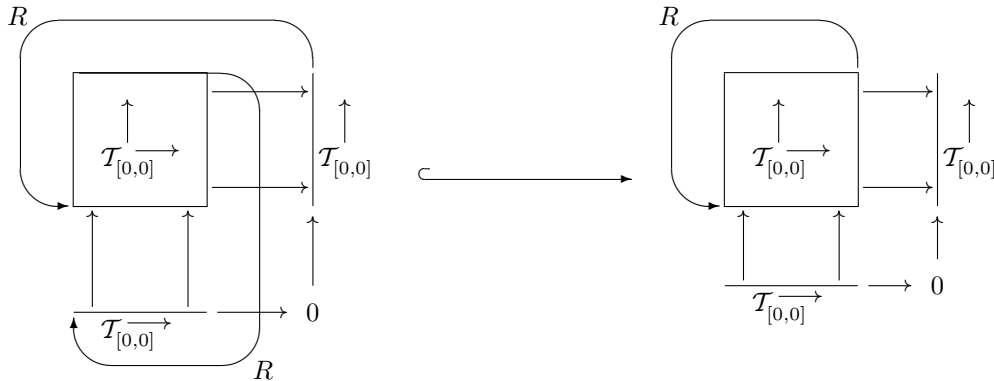

a homotopy equivalence. Let me make the following observation. In both simplicial sets, a 0-simplex is nothing other than a semi-triangle; it is a simplex

$$\begin{array}{ccc}
 V & \longrightarrow & Y \\
 \uparrow & & \uparrow \\
 U & \longrightarrow & 0
 \end{array}$$

in other words a semi-triangle

$$U \longrightarrow V \longrightarrow Y \longrightarrow \Sigma U.$$

The higher-order simplices are morphisms of semi-triangles, with the restriction that some induced semi-triangles be true triangles. If one takes an edgewise subdivision, then these simplicial sets are actually nerves of categories. I don't know whether this helps.

REFERENCES

- [1] A. A. BEILINSON, J. BERNSTEIN AND P. DELIGNE. Analyse et topologie sur les espaces singuliers. Astérisque 100, Soc. Math. France (1982).
- [2] A. BOREL AND J. P. SERRE. Le théorème de Riemann–Roch, Bull. Soc. Math. France 86 (1958), 97-136.
- [3] C. GIFFEN, AND A. NEEMAN. *K*-theory for triangulated categories. Preprint.
- [4] R. HARTSHORNE. Residues and duality, SLN 20 (1966).
- [5] V. A. HINICH AND V. V. SCHECHTMAN. Geometry of a category of complexes and algebraic *K*-theory. Duke Math. J. 52 (1985), 399-430.
- [6] J. F. JARDINE. The multiple *Q*-constructions. Canad. J. Math. 39 (1987), 1174-1209.
- [7] A. NEEMAN. Some new axioms for triangulated categories. J. of Algebra 139 (1992) 221–255.
- [8] A. NEEMAN. The Brown Representability Theorem and phantomless triangulated categories. J. of Algebra 151 (1992) 118–155.
- [9] D. QUILLLEN. Higher algebraic *K*-theory I, SLN 341 (1973), 85-147.
- [10] R. THOMASON AND T. TROBAUGH. Higher algebraic *K*-theory of schemes and of derived categories. In: The Grothendieck Festschrift (a collection of papers to honor Grothendieck's 60'th birthday) Volume 3 pp. 247–435, Birkhäuser 1990.
- [11] J. L. VERDIER. Catégories dérivées, état 0. SGA 4½, 262-308 (SLN 569, 1977).
- [12] F. WALDHAUSEN. Algebraic *K*-theory of generalized free products I, II. Ann. of Math. 108 (1978), 135-256.
- [13] F. WALDHAUSEN. Algebraic *K*-theory of spaces. SLN 1126 (1985), 318-419.