

HIGHER ORDER GENERALIZATION OF FUKAYA'S MORSE HOMOTOPY INVARIANT OF 3-MANIFOLDS I. INVARIANTS OF HOMOLOGY 3-SPHERES*

TADAYUKI WATANABE[†]

Abstract. We give a generalization of Fukaya's Morse homotopy theoretic approach for 2-loop Chern–Simons perturbation theory to 3-valent graphs with arbitrary number of loops at least 2. We construct a sequence of invariants of integral homology 3-spheres with values in a space of 3-valent graphs (Jacobi diagrams or Feynman diagrams) by counting graphs in an integral homology 3-sphere satisfying certain condition that is described by a set of ordinary differential equations.

Key words. Morse homotopy, Chern–Simons perturbation theory, homology 3-sphere.

Mathematics Subject Classification. 57M27, 57R57, 58D29, 58E05.

1. Introduction. Axelrod–Singer [AS] and Kontsevich [Ko] independently developed a method to produce topological invariants for 3-manifolds, based on perturbative expansion of Witten's path integral invariant of 3-manifolds ([Wi2, BN1, GMM]). It is called Chern–Simons perturbation theory and is defined by integrations over spaces of configurations of points on a 3-manifold. Kuperberg and Thurston [KT] studied Chern–Simons perturbation theory for homology 3-spheres and obtained a description of a diagram-valued version of topological invariants, which are proved to be universal among Ohtsuki's finite type invariants for homology 3-spheres ([Oh]), in [KT]. Here a homology 3-sphere denotes a closed 3-manifold M with $H_*(M; \mathbb{Z}) \cong H_*(S^3; \mathbb{Z})$. For homology 3-spheres, combinatorial definitions of a universal finite type invariant are known ([LMO, BGRT]), which is diagram-valued, too.

This series of articles is concerned with Fukaya's graph counting invariant of 3-manifolds, developed in [Fuk2] via Morse homotopy theory ([BC, Fuk1]) and conjectured to coincide with 2-loop Chern–Simons perturbation theory. Fukaya considered triads $\vec{f} = (f_1, f_2, f_3)$ of Morse functions on a 3-manifold M and for pairs (M, ζ_i) , $i = 1, 2$, of M and for acyclic flat Lie algebra bundles ζ_i on M , he defined some number $\hat{Z}_2(\vec{f}; \zeta_i)$. Roughly, it counts with weights the ways that the Θ -graph can be immersed such that edges follow gradient lines. The weights are determined by the holonomies taken along the edges. Fukaya showed that the difference $\hat{Z}_2(\vec{f}; \zeta_1) - \hat{Z}_2(\vec{f}; \zeta_2)$ depends only on (M, ζ_1, ζ_2) .

Fukaya discusses in [Fuk2] some heuristic argument involving the Witten deformation of de Rham complex ([Wi1, Bo]) which suggests that his invariant coincides with the 2-loop part of Chern–Simons perturbation theory. Fukaya also discusses conjectural relation with open string theory on the cotangent bundle of a manifold. His work is important for a mathematical approach to Witten's result that Chern–Simons gauge theory on a 3-manifold M is equivalent to the open string field theory of its cotangent bundle T^*M ([Wi3]).

The aim of part I of this series is to construct graph-valued invariants of \mathbb{Z} -homology 3-spheres via Morse homotopy theory, as a higher order generalization of [Fuk2]. We generalize the idea of Fukaya to graphs with the first Betti numbers ≥ 2 for

*Received November 6, 2015; accepted for publication October 24, 2016.

[†]Department of Mathematics, Shimane University, 1060 Nishikawatsu-cho, Matsue-shi, Shimane 690-8504, Japan (tadayuki@riko.shimane-u.ac.jp).

homology 3-sphere M with the trivial connection and generalize Fukaya's conjecture which asks if his invariant coincides with Chern–Simons perturbation theory. After we announced the result of this paper, T. Shimizu gave a proof of the generalized version of Fukaya's conjecture by generalizing our invariant for vector fields on \mathbb{Q} -homology spheres [Sh].

In part II, we will generalize the construction given in part I to 3-manifolds with the first Betti number 1 ([Wa2]) by considering flow-graphs with holonomies. We will obtain graph-valued invariants for 3-manifolds with the first Betti number 1. Moreover, we intended to generalize the construction in part I to 3-manifolds with positive first Betti numbers by using circle-valued Morse theory ([No, Pa]). Relevant works can be found in [Wa3, Wa4, Wa5].

As in [Fuk2], the proof that our invariant $\widehat{Z}_{2k,3k}$ is well-defined is done by a topological field theoretic argument for a 1-parameter family of smooth functions on M without higher singularities. Namely, the difference of $\widehat{Z}_{2k,3k}$ for two auxiliary choices is given by the contribution of the 0-dimensional moduli spaces at the endpoints of a 1-parameter family. The moduli spaces of flow graphs generalized suitably to 1-parameter family gives a possibly non-compact cobordism between the 0-dimensional moduli spaces on the endpoints. The cobordism may have inner ends. By counting the contributions of the inner ends in the cobordism, we may obtain the difference of $\widehat{Z}_{2k,3k}$. To make the difference trivial, or the contributions of the inner ends cancel with each other, we use some linear equations (the IHX relation [BN2]) among coefficients for the counts of the 0-dimensional moduli spaces. The point is that the proof is reduced to checking that the sum of weighted counts of flow graphs is 0. In this paper, we consider graphs for all orders, so we attempt to give a general description of the structure of a smooth manifold of a moduli space of flow graphs and of arguments of orientations etc. in a similar fashion as [BH, We].

The moduli space of flow graphs will be described as the intersections of several submanifolds of a configuration space of M or of the direct product of a configuration space of M with $[0, 1]$. We confirm the invariance of $\widehat{Z}_{2k,3k}$ one at a time by using a Cerf theoretic method as in [Ce, Hu].

Also, unlike in [Fuk2], we consider only the trivial connection contribution and we do not take the difference of terms for two flat connections as in [Fuk2]. To do so, we introduce an ‘anomaly correction’ term appropriately, as suggested in [Fuk2]. We define an anomaly term $Z_{2k,3k}^{\text{anomaly}}$ by taking some linear combination of the numbers of infinitesimal flow graphs in a vector bundle over a compact 4-manifold W with $\partial W = M$. The key point for the correction term to be well-defined is the spin cobordism invariance of the anomaly term $Z_{2k,3k}^{\text{anomaly}}$. The spin cobordism invariance allows us to define an analogue of the signature defect, which includes $Z_{2k,3k}^{\text{anomaly}}$ instead of the relative L -class, and it gives the desired correction term.

1.1. Organization. The organization of the present paper is as follows. In §2, we give definitions of Fukaya's moduli spaces \mathcal{M}_Γ of flow graphs and that of our invariant.

From §3 to §5, we give some basics for the trajectory spaces. In §3, we study the moduli space of gradient trajectories between two points and construct its compactification $\overline{\mathcal{M}}_2(f)$. In §4, we define a compactification $\overline{\mathcal{M}}_\Gamma$ of \mathcal{M}_Γ using $\overline{\mathcal{M}}_2(f)$. In §5, we study (co)orientations of the moduli spaces.

From §6 to §7, we show that our invariant depends only on a sequence of Morse functions and metrics on M . In §6, we show that the principal term $Z_{2k,3k}$ is independent of combinatorial propagator. In §7, we show that the correction term

$Z_{2k,3k}^{\text{anomaly}}(\vec{\gamma}_W) - \mu_k \text{sign } W$ is independent of the choice of 4-cobordism $(W, \vec{\gamma}_W)$.

In the final §10, we shall show that our invariant is also independent of the choice of Morse functions and metrics on M and complete the proof of the main theorem. §8 and §9 are preliminaries for §10, which give basics for the trajectory spaces in 1-parameter family, which are mainly analogues of the results in §3 to §5. In §8, we consider the compactification for the moduli space of flow graphs in 1-parameter family of smooth functions to construct cobordisms. In §9, we study (co)orientations of the moduli spaces in 1-parameter family. In §10, in accordance with the results in previous sections, we check the invariance of our invariant by a cobordism argument. For each of the four types of bifurcations that may occur in a generic 1-parameter family, we confirm the invariance one at a time.

The reader who is familiar with trajectory spaces may skip the technical sections §3, §5, §8 and most of §9.

In Appendix, we describe some facts on smooth manifolds with corners, convention for orientation, the chain complex of endomorphisms of an acyclic chain complex and the definition of blow-up.

1.2. Conventions. We denote by $C^r(M)$ the space of C^r functions $f : M \rightarrow \mathbb{R}$ on a manifold M for sufficiently large r and we equip $C^r(M)$ the Whitney C^r -topology. By smooth maps or smooth manifolds we mean C^r maps or C^r manifolds for sufficiently large r . For a C^r function f on a manifold M , we denote by $\Sigma(f)$ the subset of M of critical points of f . Let $\Sigma^1(f)$ denote the subset of $\Sigma(f)$ consisting of Morse singularities. For a Morse singularity $p \in \Sigma(f)$, we denote by $i(p)$ the Morse index of p . For a Morse function f , a critical point p of f and a Riemannian metric μ on a manifold, we denote by $\mathcal{D}_p(f) = \mathcal{D}_p(f; \mu)$ (resp. $\mathcal{A}_p(f) = \mathcal{A}_p(f; \mu)$) the descending manifold (resp. ascending manifold) of the gradient of (f, μ) at p .

We denote by $\Gamma(E)$ the space of sections of a fiber bundle $E \rightarrow B$. When considering orientations, we will often identify $\bigwedge^\bullet T_x^* X$ with $\bigwedge^\bullet T_x X$ by a (locally defined) orthonormal framing that is compatible with the orientation and treat $\bigwedge^\bullet T_x^* X$ like $\bigwedge^\bullet T_x X$.

For a sequence of submanifolds $A_1, A_2, \dots, A_r \subset W$ of a smooth Riemannian manifold W , we say that the intersection $A_1 \cap A_2 \cap \dots \cap A_r$ is *transversal* if for each point x in the intersection, the subspace $N_x A_1 + N_x A_2 + \dots + N_x A_r \subset T_x W$ spans the direct sum $N_x A_1 \oplus N_x A_2 \oplus \dots \oplus N_x A_r$, where $N_x A_i$ is the orthogonal complement of $T_x A_i$ in $T_x W$ with respect to the Riemannian metric.

The boundary of an oriented manifold is oriented by the outward normal first convention.

2. Definition of the invariant. In this section, the definition of Fukaya's moduli space of flow graphs in a manifold is recalled and the definition of our invariant is given.

2.1. Graphs. By a *graph*, we mean a finite graph with each edge oriented, i.e. an ordering of the boundary vertices of an edge is fixed. We identify a graph with its geometric realization. For an oriented edge e with orientation (v_1, v_2) , we call v_1 (resp. v_2) the input (resp. output) vertex of e . In diagrams we represent edge orientations by arrows directed toward the output vertices, as in Fig. 1. For a graph

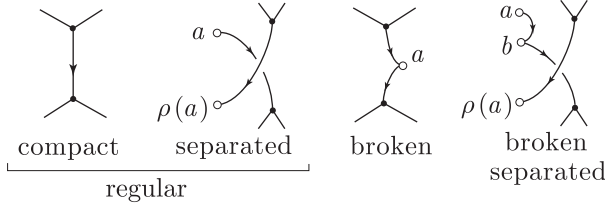

FIG. 1.

Γ , let

- $\text{In}(\Gamma) = \{\text{univalent vertices of } \Gamma \text{ that are inputs}\},$
- $\text{Out}(\Gamma) = \{\text{univalent vertices of } \Gamma \text{ that are outputs}\},$
- $W(\Gamma) = \{\text{vertices of } \Gamma \text{ of valence } \leq 2 \text{ ("white vertices")}\},$
- $B(\Gamma) = \{\text{vertices of } \Gamma \text{ of valence } \geq 3 \text{ ("black vertices")}\}.$

We define an *admissible graph* to be a pair (Γ, ρ) , where

- (1) Γ is a graph with $|\text{In}(\Gamma)| = |\text{Out}(\Gamma)|$,
- (2) $\rho : \text{In}(\Gamma) \rightarrow \text{Out}(\Gamma)$ is a fixed bijection,
- (3) each bivalent vertex has exactly one incoming and one outgoing edges,
- (4) Γ does not have a self-loop, and
- (5) no two bivalent vertices are incident to each other by a single edge.

We will omit ρ when referring to an admissible graph. For an admissible graph Γ , we consider the following (sets of) edges: (see Fig. 1)

- (1) A *compact edge* is an edge connecting two black vertices.
- (2) A *separated edge* is a pair of edges $\{(a, x), (y, b)\}$ with $x, y \in B(\Gamma)$, $a \in \text{In}(\Gamma)$, $b \in \text{Out}(\Gamma)$ such that $b = \rho(a)$.
- (3) A *broken edge* is a pair of edges $\{(x, a), (a, y)\}$ with $x, y \in B(\Gamma)$, $a \in W(\Gamma)$.
- (4) A *broken separated edge* is either a triple $\{(a, b), (b, x), (y, c)\}$ or a triple $\{(a, x), (y, b), (b, c)\}$, with $x, y \in B(\Gamma)$, $a, b, c \in W(\Gamma)$ such that $c = \rho(a)$.

Let $\text{Comp}(\Gamma)$, $\text{Se}(\Gamma)$, $\text{Br}(\Gamma)$, $\text{Se}'(\Gamma)$ be the set of compact, separated, broken, broken separated edges respectively. Let $E(\Gamma) = \text{Comp}(\Gamma) \cup \text{Se}(\Gamma) \cup \text{Br}(\Gamma) \cup \text{Se}'(\Gamma)$.

A *labeled graph* is an admissible graph Γ equipped with bijections $\alpha : \{1, 2, \dots, n\} \rightarrow B(\Gamma)$ and $\beta : \{1, 2, \dots, \ell\} \rightarrow E(\Gamma)$, where $n = |B(\Gamma)|$ and $\ell = |E(\Gamma)|$. Let $C_*^{(i)} = (C_*^{(i)}, \partial^{(i)})$, $C_*^{(i)} = \mathbb{Z}^{P_*^{(i)}}$, $i = 1, 2, \dots, \ell$, be a sequence of acyclic chain complexes over \mathbb{Z} with finite bases. For a sequence $\vec{C} = (C_*^{(1)}, \dots, C_*^{(\ell)})$, we define a \vec{C} -colored graph as a labeled graph $\Gamma = (\Gamma, \alpha, \beta)$ such that on each white vertex of $\beta(i)$ a basis element $p \in P_*^{(i)}$ is attached for each i . Later we will substitute the Morse complex of a Morse pair to each $C_*^{(i)}$. Then $P_*^{(i)}$ will correspond to the set of critical points of a Morse function.

For each edge $e = \beta(i) \in E(\Gamma)$ in a \vec{C} -colored graph, we define its *degree* by

$$\text{deg}(e) = \begin{cases} 1 & \text{if } e \in \text{Comp}(\Gamma) \\ i(p) - i(q) & \text{if } e \in \text{Se}(\Gamma), \\ 0 & \text{if } e \in \text{Br}(\Gamma) \\ i(p) - i(q) - 1 & \text{if } e \in \text{Se}'(\Gamma), \end{cases}$$

where $i(x)$ denotes the degree of x and where $p \in P_*^{(i)}$ is on the input, $q \in P_*^{(i)}$ is on the output of e . We define the *degree* of a \vec{C} -colored graph by

$\deg(\Gamma) = (\deg(\beta(1)), \dots, \deg(\beta(\ell)))$. We will call a \vec{C} -colored graph with degree $\vec{\eta} = (\eta_1, \dots, \eta_\ell)$, with n black vertices and with $|\text{Comp}(\Gamma)| + |\text{Se}(\Gamma)| = m$ a \vec{C} -colored graph of type $(n, m, \vec{\eta})$. We define the closure $\widehat{\Gamma}$ of Γ as the graph obtained from Γ by identifying white vertices of each input/output pair $(a, \rho(a))$.

2.2. The space $\mathcal{G}_{n,m,\vec{\eta}}(\vec{C})$. Let $\mathcal{G}_{n,m,\vec{\eta}}^0(\vec{C})$ be the set of pairs (Γ, o) , where

- (1) Γ is a \vec{C} -colored graph of type $(n, m, \vec{\eta})$ with connected closure $\widehat{\Gamma}$,
- (2) o is an orientation of the real vector space $\mathbb{R}^{B(\Gamma)} \oplus \bigoplus_{e \in \text{Comp}(\Gamma)} \mathbb{R}^{H(e)}$, where $H(e) = \{e_+, e_-\}$ is the two-element set of ‘half-edges’, namely $e_- = \varphi^{-1}[0, \frac{1}{2}]$ and $e_+ = \varphi^{-1}[\frac{1}{2}, 1]$ for an orientation preserving homeomorphism $\varphi : e \rightarrow [0, 1]$.

Let $\mathcal{G}_{n,m,\vec{\eta}}(\vec{C})$ be the vector space over \mathbb{Q} spanned by $\mathcal{G}_{n,m,\vec{\eta}}^0(\vec{C})$, quotiented by the relation $(\Gamma, -o) = -(\Gamma, o)$. The bijection α and the edge orientation of a labeled graph Γ define a canonical graph orientation $o(\Gamma)$, as

$$o(\Gamma) = \alpha(1) \wedge \dots \wedge \alpha(n) \wedge \bigwedge_{e \in \text{Comp}(\Gamma)} (e_+ \wedge e_-), \tag{2.1}$$

where e is oriented as (e_-, e_+) .

We denote by $\mathcal{G}_{n,m}^0(\vec{C})$ the subset of $\mathcal{G}_{n,m,(1,\dots,1)}^0(\vec{C})$ consisting of graphs without bivalent vertices such that $\ell = m$, i.e. $\vec{C} = (C_*^{(1)}, \dots, C_*^{(m)})$. Let $\mathcal{G}_{n,m}(\vec{C})$ be the subspace of $\mathcal{G}_{n,m,(1,\dots,1)}(\vec{C})$ spanned by $\mathcal{G}_{n,m}^0(\vec{C})$. Let $\mathcal{G}_{n,m,(1,\dots,1)}^{\text{comp},0}(\vec{C})$ be the subset of $\mathcal{G}_{n,m,(1,\dots,1)}^0(\vec{C})$ consisting of graphs with only compact edges. Since the sequence of complexes \vec{C} is unnecessary to represent a graph in $\mathcal{G}_{n,m,(1,\dots,1)}^{\text{comp},0}(\vec{C})$, there are canonical bijections between $\mathcal{G}_{n,m,(1,\dots,1)}^{\text{comp},0}(\vec{C})$ for different sequences \vec{C} . Identifying $\mathcal{G}_{n,m,(1,\dots,1)}^{\text{comp},0}(\vec{C})$ for all \vec{C} by the canonical bijections, we simply write

$$\mathcal{G}_{n,m}^0 = \mathcal{G}_{n,m,(1,\dots,1)}^{\text{comp},0}(\vec{C})$$

and we define $\mathcal{G}_{n,m}$ to be the vector space over \mathbb{Q} spanned by $\mathcal{G}_{n,m}^0$, quotiented by the relation $(\Gamma, -o) = -(\Gamma, o)$.

2.3. Assumption on Morse functions. We make an assumption on Morse functions, as in [Les3], [Sh, §4.1]¹. Let M be a d -dimensional homology sphere with a distinguished point $\infty_M \in M$. We consider S^d as the one point compactification $\mathbb{R}^d \cup \{\infty\}$. Let U_∞ be the open ball around ∞ :

$$U_\infty = \{x \in \mathbb{R}^d; \|x\| > R\} \cup \{\infty\} \subset S^d$$

for some large R . Fix a small open ball $U'_\infty \subset M$ including ∞_M and a diffeomorphism $\varphi_\infty : U'_\infty \rightarrow U_\infty$ which sends ∞_M to ∞ . We consider a Morse function on $M_0 = M - \{\infty_M\}$ and a Riemannian metric μ on M_0 that are *standard near ∞_M* . We say that a function $f : M_0 \rightarrow \mathbb{R}$ is standard near ∞_M if $f|_{U'_\infty - \{\infty_M\}}$ agrees with the pullback of a rank one linear map $\mathbb{R}^d \rightarrow \mathbb{R}$ by φ_∞ . Similarly, we say that a Riemannian

¹In an earlier version of the present paper, we did not make such an assumption. But the referee pointed out that without this assumption, there may be some boundary strata in the trajectory spaces which may violate the invariance of $\widehat{Z}_{2k,3k}$. Considering a homology sphere with one point removed as the connected sum of \mathbb{R}^d with a homology sphere was utilized in [Ko].

metric μ on M_0 is standard near ∞_M if the restriction of μ to $T(U'_\infty - \{\infty_M\})$ agrees with the pullback of the standard metric on \mathbb{R}^d by φ_∞ . Let $C^r_{\varphi_\infty}(M_0)$ denote the subspace of $C^r(M_0)$ consisting of functions that are standard near ∞_M with respect to φ_∞ .

ASSUMPTION 2.1. Fix a sufficiently large integer $r > 0$. Throughout this paper, a Morse function on M_0 is always a C^r Morse function $f : M_0 \rightarrow \mathbb{R}$ that is standard near ∞_M and a Riemannian metric μ on M_0 is always a Riemannian metric on M_0 that is standard near ∞_M .

2.4. Fukaya’s moduli space \mathcal{M}_Γ . Suppose given a sequence $\vec{f} = (f_1, f_2, \dots, f_m)$ of Morse functions on M_0 and a Riemannian metric μ on M_0 . Suppose that (f_i, μ) is Morse–Smale for each i , namely, all the intersections between the descending manifolds and the ascending manifolds of the gradient of f_i are transversal. We choose an orientation $o(\mathcal{D}_p(f_i))$ of $\mathcal{D}_p(f_i)$ arbitrarily for each critical point p of f_i and orient $\mathcal{A}_p(f_i)$ by $o(\mathcal{A}_p(f_i)) = *o(\mathcal{D}_p(f_i))$ near p , where $*$ is the Hodge star operator. Let $C^{(i)} = (C^{(i)} = \mathbb{Z}^{P^{(i)}}, \partial^{(i)})$ be the Morse complex associated to (f_i, μ) , namely, $C^{(i)}$ is the free \mathbb{Z} -module generated by the (finite) set $P_*^{(i)}$ of critical points of f_i and $\partial^{(i)} : C_{k+1}^{(i)} \rightarrow C_k^{(i)}$ is defined by

$$\partial^{(i)}p = \sum_{q \in P_k^{(i)}} \# \mathcal{M}'(f_i; p, q) \cdot q, \quad \mathcal{M}'(f_i; p, q) = (\mathcal{D}_p(f_i) \pitchfork \mathcal{A}_q(f_i)) \pitchfork L_p,$$

where L_p is a level surface of f_i that lies just below the level of p and $\mathcal{M}'(f_i; p, q)$ is an oriented 0-manifold whose orientation is derived from those of $\mathcal{D}_p(f_i)$ and $\mathcal{A}_q(f_i)$. More precisely, $\mathcal{D}_p(f_i) \pitchfork \mathcal{A}_q(f_i)$ is a disjoint union of flow lines of $-\text{grad } f_i$. At each point $b \in \mathcal{M}'(f_i; p, q)$, the wedge $o_M^*(\mathcal{D}_p(f_i))_b \wedge o_M^*(\mathcal{A}_q(f_i))_b \in \bigwedge^{d-1} T_b^* L_p \subset \bigwedge^{d-1} T_b^* M$ defines a coorientation of the flow line passing through b (see Appendix B (B.4)). Hence there exists a sign $\varepsilon_{f_i}(p, q)_b = \pm 1$ such that

$$o_M^*(\mathcal{D}_p(f_i))_b \wedge o_M^*(\mathcal{A}_q(f_i))_b \sim \varepsilon_{f_i}(p, q)_b \iota(-\text{grad } f_i)o(M)_b.$$

The sign $\varepsilon_{f_i}(p, q)_b$ does not depend on the choice of L_p .

Then the incidence coefficient is defined by

$$\# \mathcal{M}'(f_i; p, q) = \sum_{b \in \mathcal{M}'(f_i; p, q)} \varepsilon_{f_i}(p, q)_b.$$

It is known that $(C^{(i)}, \partial^{(i)})$ above is a chain complex called a Morse complex (e.g. [Bo], see also Corollary 5.3). Moreover, $(C^{(i)}, \partial^{(i)})$ is acyclic by Assumption 2.1. We put $\vec{C} = (C^{(1)}, C^{(2)}, \dots, C^{(m)})$.

Now we give a definition of Fukaya’s moduli space $\mathcal{M}_\Gamma(\vec{f})$. For $\Gamma = (\Gamma, \alpha, \beta) \in \mathcal{G}_{n,m}^0(\vec{C})$, we define the source and the target maps

$$\sigma : \{1, 2, \dots, m\} \rightarrow \{1, 2, \dots, n\}, \quad \tau : \{1, 2, \dots, m\} \rightarrow \{1, 2, \dots, n\}$$

as $\sigma(k) = \alpha^{-1}(\text{source of } \beta(k))$, $\tau(k) = \alpha^{-1}(\text{target of } \beta(k))$. For each $i \in \{1, 2, \dots, n\}$, we define the subsets $\text{In}_i(\Gamma) = \{k_1^i, k_2^i, \dots, k_{r_i}^i\}$, $\text{In}_i^\infty(\Gamma) = \{\bar{k}_1^i, \bar{k}_2^i, \dots, \bar{k}_{\bar{r}_i}^i\}$, $\text{Out}_i^\infty(\Gamma) = \{\bar{\ell}_1^i, \bar{\ell}_2^i, \dots, \bar{\ell}_{\bar{s}_i}^i\}$ of the set of labels $\{1, 2, \dots, m\}$ of edges as the subsets

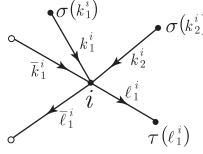

FIG. 2. Labels for edges incident to the i -th vertex. $\tau(k_1^i) = \tau(k_2^i) = i = \sigma(\ell_1^i)$.

consisting of labels of edges such that

$$\begin{aligned} k_j^i &\in \text{In}_i(\Gamma) \Leftrightarrow \tau(k_j^i) = i \text{ and } \beta(k_j^i) \in \text{Comp}(\Gamma), \\ \bar{k}_j^i &\in \text{In}_i^\infty(\Gamma) \Leftrightarrow \tau(\bar{k}_j^i) = i \text{ and } \beta(\bar{k}_j^i) \in \text{Se}(\Gamma), \\ \bar{\ell}_j^i &\in \text{Out}_i^\infty(\Gamma) \Leftrightarrow \sigma(\bar{\ell}_j^i) = i \text{ and } \beta(\bar{\ell}_j^i) \in \text{Se}(\Gamma). \end{aligned}$$

For example, $\text{In}_i(\Gamma)$ is the subset of labels of incoming compact edges at the i -th vertex and $\text{In}_i^\infty(\Gamma)$ is the subset of labels of incoming separated edges at the i -th vertex. See Fig. 2.

For a Morse function f on M , let $\Phi_f^t : M \rightarrow M$ denote the one parameter group of diffeomorphisms associated to $-\text{grad } f$.

DEFINITION 2.2. For $\vec{f} = (f_1, \dots, f_m)$ and Γ without bivalent vertices, let $\mathcal{M}_\Gamma(\vec{f}) = \mathcal{M}_\Gamma(\vec{f}; \mu)$ be the space of points $(x_1, \dots, x_n) \in M_0^n$ such that

- (1) for $1 \leq i \leq n$, $1 \leq j \leq r_i$ such that $k_j^i \in \text{In}_i(\Gamma)$, there exists $t_{k_j^i} > 0$ such that $\Phi_{f_{k_j^i}}^{t_{k_j^i}}(x_{\sigma(k_j^i)}) = x_i$,
- (2) $\lim_{t \rightarrow -\infty} \Phi_{f_{\bar{k}_j^i}}^t(x_i) = p_{\bar{k}_j^i}$ for $1 \leq i \leq n$, $1 \leq j \leq \bar{r}_i$ such that $\bar{k}_j^i \in \text{In}_i^\infty(\Gamma)$, where $p_{\bar{k}_j^i} \in P^{(\bar{k}_j^i)}$ is the one attached to the input of the edge labeled \bar{k}_j^i ,
- (3) $\lim_{t \rightarrow +\infty} \Phi_{f_{\bar{\ell}_j^i}}^t(x_i) = q_{\bar{\ell}_j^i}$ for $1 \leq i \leq n$, $1 \leq j \leq \bar{s}_i$ such that $\bar{\ell}_j^i \in \text{Out}_i^\infty(\Gamma)$, where $q_{\bar{\ell}_j^i} \in P^{(\bar{\ell}_j^i)}$ is the one attached to the output of the edge labeled $\bar{\ell}_j^i$.

REMARK 2.3. Since $\Phi_f^t(p) = p$ ($\forall t$) for a critical point p of f , we allow for a point (x_1, \dots, x_n) of $\mathcal{M}_\Gamma(\vec{f})$ that some x_i coincides with a critical point of some f_j . We will see later that such a point is not a singular point of $\mathcal{M}_\Gamma(\vec{f})$.

2.5. The count of \mathcal{M}_Γ .

PROPOSITION 2.4 (page 49 of [Fuk2]). Suppose that $\Gamma \in \mathcal{G}_{n,m,\vec{\eta}}^0(\vec{C})$ has no bivalent vertex, i.e. $E(\Gamma) = \text{Comp}(\Gamma) \cup \text{Se}(\Gamma)$. For a generic choice of \vec{f} , the space $\mathcal{M}_\Gamma(\vec{f})$ is a C^{r-1} smooth manifold of dimension $(n - m)d + \sum_{i=1}^m \eta_i$. Moreover, \vec{f} can be chosen so that this property is satisfied simultaneously for all graphs Γ in $\mathcal{G}_{n,m,\vec{\eta}}^0(\vec{C})$ for a fixed triple $m, n, \sum_{i=1}^m \eta_i$.

The proof of Proposition 2.4 will be reviewed in §4.1. The reason for the dimension is roughly that an edge e of degree $i(e)$ yields a $(d - i(e))$ -dimensional constraint. Since $\dim M_0^n = nd$, the dimension of the moduli space should be $nd - \sum_{e \in E(\Gamma)} (d - i(e)) = nd - md + \sum_e i(e)$. The reason for the class C^{r-1} is that the solution for the differential equation $\dot{\gamma}(t) = -(\text{grad } f)_{\gamma(t)}$ for a C^r Morse function is of class C^{r-1} .

As in [Fuk2], we will need a compactification of the moduli space $\mathcal{M}_\Gamma(\vec{f})$ for Γ with only trivalent black vertices. If Γ has only trivalent black vertices and does not have bivalent vertices, then $n = 2k$ and $m = 3k$. For simplicity, we take a convenient metric for each Morse function. Namely, for $\vec{f} = (f_1, f_2, \dots, f_{3k})$, we take a sequence $\vec{\mu} = (\mu_1, \mu_2, \dots, \mu_{3k})$ of Riemannian metrics on M_0 such that for each i the pair (f_i, μ_i) is Morse–Smale and that μ_i is Euclidean near $\Sigma(f_i)$ with respect to the coordinate of the Morse lemma.

PROPOSITION 2.5. *Suppose $d = 3$ and that $(\vec{f}, \vec{\mu})$ is as above and is generic as in Proposition 2.4. Suppose that $\Gamma \in \mathcal{G}_{2k, 3k, \vec{\eta}}^0(\vec{C})$ is such that $|E(\Gamma)| = 3k$ and such that $\eta_1, \dots, \eta_{3k} \geq 0$ and $0 \leq \dim \mathcal{M}_\Gamma(\vec{f}) = (\eta_1 - 1) + (\eta_2 - 1) + \dots + (\eta_{3k} - 1) \leq 1$. Then $\mathcal{M}_\Gamma(\vec{f})$ has a natural compactification to a smooth manifold $\overline{\mathcal{M}}_\Gamma(\vec{f})$ with boundary, whose boundary consists of flow graphs with a once broken trajectory or with a subgraph collapsed to a point.*

The proof of Proposition 2.5 will be given in §4.3. Proposition 2.4 implies that for Γ as in Proposition 2.5 with $\eta_1 = \dots = \eta_{3k} = 1$, we have $\dim \mathcal{M}_\Gamma(\vec{f}) = 0$. In fact, $\overline{\mathcal{M}}_\Gamma(\vec{f}) = \mathcal{M}_\Gamma(\vec{f})$ in this case. Then we count points in the finite set $\mathcal{M}_\Gamma(\vec{f})$ with signs as follows. Let $(x_1, \dots, x_{2k}) \in \mathcal{M}_\Gamma(\vec{f})$. For each edge $e \in E(\Gamma)$, we assign a vector

$$v_e \in \wedge^2(T_x M_0 \oplus T_y M_0),$$

where $x = x_{\sigma(i)}$, $y = x_{\tau(i)}$, $i = \beta^{-1}(e)$, as follows.

If $e \in \text{Comp}(\Gamma)$, let e_1, e_2, e_3 be an orthonormal basis of $T_x M_0$ such that $e_1 \wedge e_2 \wedge e_3$ gives the orientation of M_0 and e_1 is a positive multiple of $-(\text{grad } f_i)_x$. There is $t_0 > 0$ such that $y = \Phi_{f_i}^{t_0}(x)$. The flow $\Phi_{f_i}^{t_0}$ induces a diffeomorphism from a neighborhood of x to that of y . Let $e'_i = d\Phi_{f_i}^{t_0}(e_i) \in T_y M_0$ ($i = 1, 2, 3$). Let $n_2, n_3 \in T_x M_0 \oplus T_y M_0$ be a basis of $\langle e_1 + e'_1, e_2 + e'_2, e_3 + e'_3, e'_1 \rangle^\perp$ such that $(e_1 + e'_1) \wedge (e_2 + e'_2) \wedge (e_3 + e'_3) \wedge e'_1 \wedge n_2 \wedge n_3 = e_1 \wedge e_2 \wedge e_3 \wedge e'_1 \wedge e'_2 \wedge e'_3$. We define

$$v_e = n_2 \wedge n_3.$$

If $e \in \text{Se}(\Gamma)$, let p and q be the critical points of f_i that are the input and the output of the i -th edge in the flow graph. Let e_1, e_2, e_3 be an orthonormal basis of $T_x M_0$ such that $T_x \mathcal{A}_q(f_i) = \langle e_1, \dots, e_r \rangle$, $T_x \mathcal{A}_q(f_i)^\perp = \langle e_{r+1}, \dots, e_3 \rangle$ and $e_1 \wedge \dots \wedge e_r$ and $e_1 \wedge e_2 \wedge e_3$ give the orientations of $\mathcal{A}_q(f_i)$ and M_0 respectively. Similarly, let e'_1, e'_2, e'_3 be an orthonormal basis of $T_y M_0$ such that $T_y \mathcal{D}_p(f_i) = \langle e'_1, \dots, e'_s \rangle$, $T_y \mathcal{D}_p(f_i)^\perp = \langle e'_{s+1}, \dots, e'_3 \rangle$ and $e'_1 \wedge \dots \wedge e'_s$ and $e'_1 \wedge e'_2 \wedge e'_3$ give the orientations of $\mathcal{D}_p(f_i)$ and M_0 respectively. Then we define

$$v_e = (e_{r+1} \wedge \dots \wedge e_3) \wedge (e'_{s+1} \wedge \dots \wedge e'_3),$$

which belongs to $\wedge^2 T_{(x,y)}(M_0 \times M_0)$ if $\eta_i = i(p) - i(q) = 1$.

Let $V(x_1, \dots, x_{2k}) = \bigwedge_{e \in E(\Gamma)} v_e \in \wedge^{6k} T_{(x_1, \dots, x_{2k})}(M_0^{2k})$. Since $\dim M_0^{2k} = 6k$, there is a nonzero real number α such that $V(x_1, \dots, x_{2k}) = \alpha O_{x_1} \wedge \dots \wedge O_{x_{2k}}$, where $O_{x_j} \in \wedge^3 T_{x_j} M_0$ gives the unit volume. For $(x_1, \dots, x_{2k}) \in \mathcal{M}_\Gamma(\vec{f})$, we define

$$\varepsilon(x_1, \dots, x_{2k}) = \begin{cases} 1 & \text{if } \alpha > 0 \\ -1 & \text{if } \alpha < 0 \end{cases}$$

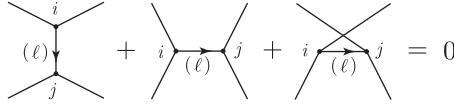

FIG. 3. The IHX relation. i and j are labels of vertices, (ℓ) is a label of an edge.

For a generic pair $(\vec{f}, \vec{\eta})$ as in Proposition 2.5, the coefficient α is always nonzero for all points of $\mathcal{M}_\Gamma(\vec{f})$. We define

$$\#\mathcal{M}_\Gamma(\vec{f}) = \sum_{(x_1, \dots, x_{2k}) \in \mathcal{M}_\Gamma(\vec{f})} \varepsilon(x_1, \dots, x_{2k}) \in \mathbb{Z}.$$

2.6. Principal term $Z_{2k,3k}$. The space $\mathcal{G}_{2k,3k}$ (§2.2) is spanned by 3-valent graphs with only compact edges. Let $\mathcal{R}_{2k,3k} \subset \mathcal{G}_{2k,3k}$ be the subspace spanned by the IHX relation and the label change relation. The IHX relation is shown in Fig. 3 and the label change relation is generated by the following elements

- (1) $(\Gamma, o(\Gamma)) + (\Gamma', o(\Gamma'))$ for labeled graphs Γ and Γ' , where Γ' is obtained from Γ by a swap of a pair of vertex labels or by an inversion of the orientation of an edge.
- (2) $(\Gamma, o(\Gamma)) - (\Gamma', o(\Gamma'))$ for labeled graphs Γ and Γ' , where Γ' is obtained from Γ by a swap of a pair of labels for compact edges.

We define the space $\mathcal{A}_{2k,3k}$ to be the quotient space $\mathcal{G}_{2k,3k}/\mathcal{R}_{2k,3k}$. This is the same thing as the degree k part of $\mathcal{A}(\emptyset)$ in [BGRT]. We denote by $[\Gamma]$ the equivalence class in $\mathcal{A}_{2k,3k}$ represented by $\Gamma \in \mathcal{G}_{2k,3k}^0$.

Let Γ be a \vec{C} -labeled graph with $p_i \in P_*^{(i)}$ on the input and $q_i \in P_*^{(i)}$ on the output. For simplicity, we first suppose that $\text{Se}(\Gamma)$ is labeled by $\{1, 2, \dots, a\}$. Let $k_i = i(p_i) - i(q_i)$. For a sequence $\vec{h} = (h^{(1)}, \dots, h^{(m)})$ of endomorphisms $h^{(i)} \in \text{End}_{k_i}(C_*^{(i)})$, $i = 1, 2, \dots, m$, of homogeneous degree k_i , we define the trace of Γ by

$$\text{Tr}_{\vec{h}} \left(\begin{array}{c} \left(\begin{array}{ccc} p_1 & p_2 & p_a \\ \circ & \circ & \circ \\ \vdots & \vdots & \vdots \\ \circ & \circ & \circ \\ \hline \Gamma \\ \hline \circ & \circ & \circ \\ q_1 & q_2 & q_a \end{array} \right) \\ \vdots \\ \circ & \circ & \circ \\ q_1 & q_2 & q_a \end{array} \right) = \prod_{i=1}^a (-h_{q_i p_i}^{(i)}) \times \left(\begin{array}{c} \text{Diagram with loops and crossings} \end{array} \right),$$

where $h^{(i)} q_i = \sum_{\substack{p_i \in P_*^{(i)} \\ i(p_i) = i(q_i) + k_i}} h_{q_i p_i}^{(i)} p_i$. Then the definition of Tr for general labelings on $\text{Se}(\Gamma)$ may be obtained by a straightforward modification.

In particular, since each $(C_*^{(i)}, \partial^{(i)})$ is acyclic, there exists an endomorphism $g^{(i)} : C_*^{(i)} \rightarrow C_{*+1}^{(i)}$ of homogeneous degree 1 such that $\partial^{(i)} g^{(i)} + g^{(i)} \partial^{(i)} = \text{id}$. (See Appendix C. Following [Fuk2], we call such an endomorphism a *combinatorial propagator*). As a special case of the above definition, the trace by combinatorial propagators $\vec{g} = (g^{(1)}, \dots, g^{(3k)})$ defines a linear map $\text{Tr}_{\vec{g}} : \mathcal{G}_{2k,3k}(\vec{C}) \rightarrow \mathcal{A}_{2k,3k}$.

DEFINITION 2.6. Suppose $d = 3$. We define

$$Z_{2k,3k}(\vec{f}) = \sum_{\Gamma \in \mathcal{G}_{2k,3k}^0(\vec{C})} \#\mathcal{M}_\Gamma(\vec{f}) \text{Tr}_{\vec{g}}(\Gamma) \in \mathcal{A}_{2k,3k},$$

where the sum is taken over all \vec{C} -colored graphs in $\mathcal{G}_{2k,3k}^0(\vec{C})$, each equipped with canonical orientation.

2.7. Moduli space of infinitesimal flow graphs. In the rest of this section, we define the correction term which turns $Z_{2k,3k}$ into a topological invariant. Let X be an oriented smooth Riemannian manifold and Γ be a graph with only compact edges. Suppose that Γ has n vertices and m edges. We shall consider the moduli space of affine flow graphs in an oriented linear \mathbb{R}^3 -bundle $\pi : E \rightarrow X$ with metric for such a graph Γ . Let $P \rightarrow X$ be the orthonormal SO_3 -frame bundle associated to π and

$$C_n^{\text{local}}(\mathbb{R}^3) = \left\{ (y_1, \dots, y_n) \in (\mathbb{R}^3)^n; y_1 = 0, \sum_{\ell=2}^n \|y_\ell\|^2 = 1, y_i \neq y_j \text{ if } i \neq j \right\}.$$

Let $\pi^\circ : E^\circ = P \times_{SO_3} (\mathbb{R}^3 - \{0\}) \rightarrow X$, $S(\pi) : S(E) = P \times_{SO_3} S^2 \rightarrow X$, $C_n^{\text{local}}(\pi) : C_n^{\text{local}}(E) = P \times_{SO_3} C_n^{\text{local}}(\mathbb{R}^3) \rightarrow X$ be the bundles associated to π . Such a bundle appears in a boundary strata of compactified configuration space (see §4.2). The normalization $v \mapsto v/\|v\|$ induces a natural map $\nu : E^\circ \rightarrow S(E)$. The Gauss map $\phi_{ij} : C_n^{\text{local}}(\mathbb{R}^3) \rightarrow S^2$, which takes (y_1, \dots, y_n) to $\frac{y_i - y_j}{\|y_j - y_i\|}$, induces a well-defined morphism $\tilde{\phi}_{ij} : C_n^{\text{local}}(E) \rightarrow S(E)$.

Now suppose that a section $\gamma : X \rightarrow E^\circ$ of π° is given. Then $\bar{\gamma} = \nu \circ \gamma : X \rightarrow S(E)$ is a section of $S(\pi)$. Since $\tilde{\phi}_{ij}$ is transversal to $\bar{\gamma}(X)$ on each fiber, the subset

$$\Theta_\ell(\gamma) = \tilde{\phi}_{ij}^{-1}(\bar{\gamma}(X)) \subset C_n^{\text{local}}(E)$$

forms a smooth subbundle of $C_n^{\text{local}}(\pi)$ where ℓ is such that $i = \sigma(\ell)$ and $j = \tau(\ell)$.

DEFINITION 2.7. For a sequence $\vec{\gamma} = (\gamma_1, \gamma_2, \dots, \gamma_m)$ of sections of π° , we define

$$\mathcal{M}_\Gamma^{\text{local}}(\vec{\gamma}) = \bigcap_{\ell=1}^m \Theta_\ell(\gamma_\ell) \subset C_n^{\text{local}}(E)$$

for a sequence $\vec{\gamma} = (\gamma_1, \dots, \gamma_m)$ of sections of π° . If the intersection is transversal, in other words, if $\bigwedge_{\ell=1}^m \theta_{C_n^{\text{local}}(E)}^*(\Theta_\ell(\gamma_\ell)) \neq 0$ at every point of $\mathcal{M}_\Gamma^{\text{local}}(\vec{\gamma})$, this formula also defines a co-orientation of $\mathcal{M}_\Gamma^{\text{local}}(\vec{\gamma})$.

There is a compactification $\overline{C}_n^{\text{local}}(\mathbb{R}^3)$ of $C_n^{\text{local}}(\mathbb{R}^3)$, which is naturally an SO_3 -space. See §4.2. Let $\overline{C}_n^{\text{local}}(\pi) : \overline{C}_n^{\text{local}}(E) \rightarrow X$ be the $\overline{C}_n^{\text{local}}(\mathbb{R}^3)$ -bundle associated to π . The interior of $\overline{C}_n^{\text{local}}(\mathbb{R}^3)$ is identified with $C_n^{\text{local}}(\mathbb{R}^3)$. Let $\overline{\Theta}_\ell(\gamma) \subset \overline{C}_n^{\text{local}}(E)$ be the closure of $\Theta_\ell(\gamma)$. Let

$$\overline{\mathcal{M}}_\Gamma^{\text{local}}(\vec{\gamma}) = \bigcap_{\ell=1}^m \overline{\Theta}_\ell(\gamma_\ell). \quad (2.2)$$

LEMMA 2.8. For a generic choice of $\vec{\gamma}$, the space $\overline{\mathcal{M}}_\Gamma^{\text{local}}(\vec{\gamma})$ is a submanifold of $\overline{C}_n^{\text{local}}(E)$ of codimension $2m$. If X is compact, then so is $\overline{\mathcal{M}}_\Gamma^{\text{local}}(\vec{\gamma})$.

Proof. Note that $\overline{\Theta}_k(\gamma)$ is a submanifold of codimension 2. By using the transversality theorem, the set of sections $\vec{\gamma}$ can be inductively deformed in $\Gamma(\pi)^m$ slightly so

that the intersection (2.2) is transversal. Thus for a generic choice of $\vec{\gamma}$, $\overline{\mathcal{M}}_\Gamma^{\text{local}}(\vec{\gamma})$ is a submanifold. The second assertion is immediate. \square

When $\vec{\gamma}$ is generic as in Lemma 2.8 and X is compact and $\dim \overline{\mathcal{M}}_\Gamma^{\text{local}}(\vec{\gamma}) = 0$, we define $\#\overline{\mathcal{M}}_\Gamma^{\text{local}}(\vec{\gamma})$ to be the number of components counted with signs, which are determined by the coorientations of the intersections. Here we fix the orientation $o(\overline{C}_n^{\text{local}}(\mathbb{R}^3))$ to be the one on the unit sphere induced from that of the Euclidean space $(\mathbb{R}^3)^{n-1}$. Then we orient $\overline{C}_n^{\text{local}}(E)$ by

$$o(\overline{C}_n^{\text{local}}(E)) = o(X) \wedge o(\overline{C}_n^{\text{local}}(\mathbb{R}^3)).$$

2.8. Anomaly term $Z_{2k,3k}^{\text{anomaly}}$. Here, we shall define the term $Z_{2k,3k}^{\text{anomaly}}(\vec{\gamma}_W)$ for a sequence $\vec{\gamma}_W$ of sections of a vector bundle T^vW over a spin 4-manifold W with $\partial W \cong M$. To do this we shall first find a trivialization of TW and consider its trivial subbundle T^vW .

2.8.1. Framing on spin cobordism. For a k -manifold X , a *framing* on X is a trivialization $\tau_X : TX \rightarrow X \times \mathbb{R}^k$. More generally, we will also call a trivialization of a vector bundle a framing. We will identify a framing with a finite set of sections of a vector bundle that are fiberwise linearly independent. We shall fix framings on M_0 and on a spin 4-manifold W with $\partial W = M$ in a sense compatible with each other. Recall that for $k \geq 3$, a spin structure on a vector bundle E over a CW-complex B is a homotopy class of framings on the 1-skeleton of E which can be extended to the 2-skeleton ([Mil]). A spin structure on a tangent bundle of a manifold X is called a spin structure on X . Since the group Ω_3^{spin} of spin cobordism classes of spin 3-manifolds is trivial (e.g., [Mil]), one can find a compact spin 4-manifold W with $\partial W = M$ and with a spin structure that is compatible with the (canonical) spin structure of M .

We choose a framing τ_M on TM_0 , which exists for any M . We fix τ_M such that it agrees on $U'_\infty - \{\infty_M\}$ with the pullback of the standard one $\tau_{\mathbb{R}^3}$ on $U_\infty - \{\infty\}$ by $d\varphi_\infty^{-1}$. One may check that such a framing really exists by the obstruction theory for extending sections. Let \overline{U}_∞ be the closure of $U_\infty \subset S^3$ and let

$$M = (M - U'_\infty) \cup_{\partial} ([0, 1] \times \partial \overline{U}_\infty) \cup_{\partial} -(S^3 - U_\infty),$$

where $\partial(M - U'_\infty)$ is identified with $\{1\} \times \overline{U}_\infty$ by φ_∞ and $\partial(S^3 - U_\infty) = \partial \overline{U}_\infty$ is identified with $\{0\} \times \partial \overline{U}_\infty$. Then M is diffeomorphic to M . We construct a rank 3 vector bundle T^vM on M as follows. Consider $[0, 1] \times \partial \overline{U}_\infty$ as a part of $[0, 1] \times \overline{U}_\infty$. Let $T^v([0, 1] \times \overline{U}_\infty)$ be the pullback of $T\overline{U}_\infty$ by the projection $[0, 1] \times \overline{U}_\infty \rightarrow \overline{U}_\infty$. Let $T^v([0, 1] \times \partial \overline{U}_\infty)$ be the restriction of $T^v([0, 1] \times \overline{U}_\infty)$ to $[0, 1] \times \partial \overline{U}_\infty$. We define

$$T^vM = T(M - U'_\infty) \cup T^v([0, 1] \times \partial \overline{U}_\infty) \cup T(-(S^3 - U_\infty)).$$

The rank 4 vector bundle $T([0, 1] \times \overline{U}_\infty)$ restricts on $\{0, 1\} \times \partial \overline{U}_\infty$ to the restrictions of $\varepsilon^1 \oplus TM$ and $\varepsilon^1 \oplus T(-S^3)$, where ε^1 denotes the trivial line bundle. Thus by extending $T([0, 1] \times \overline{U}_\infty)|_{[0,1] \times \partial \overline{U}_\infty}$ by the restrictions of $\varepsilon^1 \oplus T(M - U'_\infty)$ and $\varepsilon^1 \oplus T(-(S^3 - U_\infty))$, we obtain a \mathbb{R}^4 -bundle over M of the form $\varepsilon^1 \oplus T^vM$.

Let n be a framing of ε^1 . The 4-framings $n \oplus \tau_M$ and $n \oplus \tau_{\mathbb{R}^3}$ of $\varepsilon^1 \oplus T(M - U'_\infty)$ and $\varepsilon^1 \oplus T(-(S^3 - U_\infty))$ respectively extend over $\varepsilon^1 \oplus T^vM$ by using the product structure. We denote by τ'_M the resulting 4-framing of $\varepsilon^1 \oplus T^vM$.

The following lemma follows from Lemma 2.3 of [KM], Lemma 2.40 of [Les1] and from the proof of [KM, Theorem 2.6].

LEMMA 2.9.

- (1) *There exists a compact spin 4-manifold W with corners with $\partial W = M$ as the spin boundary such that $\chi(W) = 1$.*
- (2) *Let W be as in (1). The 4-framing τ'_M extends to a framing of TW if and only if $p_1(TW; \tau'_M) = 0$, where $p_1(TW; \tau'_M) \in \mathbb{Z}$ denotes the relative Pontrjagin number. Moreover, there exists a framing τ_M of M_0 that is standard near ∞_M and that satisfies $p_1(TW; \tau'_M) = 0$.*

2.8.2. Generalized Morse sections. Let $\pi : E \rightarrow X$ be a linear \mathbb{R}^d -bundle over a compact manifold X possibly with corners with $\dim X = N \geq d$. We say that a smooth section $\gamma : X \rightarrow E$ is *generalized Morse (GM)* if for each point $x \in \gamma^{-1}(0)$, there is a local coordinate (y_1, \dots, y_N) on an open neighborhood U of x and a trivialization $\varphi : \pi^{-1}(U) \rightarrow U \times \mathbb{R}^d$ such that either of the following holds².

- (1) $\gamma(y_1, \dots, y_N) = \varphi^{-1}(y_1, \dots, y_N, \pm y_1, \dots, \pm y_d) \quad \forall (y_1, \dots, y_N) \in U$
- (2) $\gamma(y_1, \dots, y_N) = \varphi^{-1}(y_1, \dots, y_N, y_1^2 - y_{d+1}, \pm y_2, \dots, \pm y_d) \quad \forall (y_1, \dots, y_N) \in U$

When γ is GM, we call a point $x \in \gamma^{-1}(0)$ having local form (1) (resp. (2)) a *Morse singularity* (resp. *birth-death singularity*) of γ . We write $\Sigma(\gamma) = \gamma^{-1}(0)$ and let $\Sigma^1(\gamma)$ (resp. $\Sigma^2(\gamma)$) be the subset of $\Sigma(\gamma)$ consisting of Morse singularities (resp. birth-death singularities). An obvious example with $\Sigma^2(\gamma) = \emptyset$ is the section $M_0 \rightarrow TM_0$ given by the gradient of a Morse function. The following lemma is an immediate consequence of results of K. Igusa ([Ig1, Lemma 2.8] and [Ig2, Appendix 2]).

LEMMA 2.10. *Let $\pi : E \rightarrow X$ be as above. Suppose that the restriction of a smooth section $\gamma : X \rightarrow E$ to ∂X is GM. Then there is a homotopy of γ relative to ∂X whose result is GM. Hence $\Sigma^2(\gamma)$ is a codimension 1 submanifold of $\Sigma(\gamma)$.*

2.8.3. Definition of $Z_{2k,3k}^{\text{anomaly}}$. Now let (W, τ'_M) be a pair satisfying the condition of Lemma 2.9. One can find a (non-unique) 4-framing of TW as in Lemma 2.9 and let τ_W^v be its sub 3-framing of TW that extends τ_M . The 3-framing τ_W^v spans a rank 3 subbundle T^vW of TW . For each $i \in \{1, 2, \dots, 3k\}$, let γ_i be a GM section of T^vW extending $-\text{grad } f_i \in \Gamma(T(M - U'_\infty))$ and put $\vec{\gamma}_W = (\gamma_1, \dots, \gamma_{3k})$.

DEFINITION 2.11. We define

$$Z_{2k,3k}^{\text{anomaly}}(\vec{\gamma}_W) = \sum_{\Gamma \in \mathcal{G}_{2k,3k}^0} \# \mathcal{M}_\Gamma^{\text{local}}(\vec{\gamma}_W) [\Gamma] \in \mathcal{A}_{2k,3k},$$

where the moduli space $\mathcal{M}_\Gamma^{\text{local}}(\vec{\gamma}_W)$ is considered inside the trivial $\overline{\mathcal{C}}_{2k}^{\text{local}}(\mathbb{R}^3)$ -bundle over $\bigcap_{j=1}^{3k} (W - \Sigma(\gamma_j))$ associated to the restriction of the \mathbb{R}^3 -bundle T^vW .

PROPOSITION 2.12.

- (1) *For a generic choice of the GM extension $\vec{\gamma}_W$ of $-\text{grad } \vec{f} = (-\text{grad } f_1, \dots, -\text{grad } f_{3k})$, the number $\# \mathcal{M}_\Gamma^{\text{local}}(\vec{\gamma}_W)$ is finite.*
- (2) *Let W and W' be compact, connected, spin 4-manifolds with corners with $\partial W = \partial W' = M$, $\chi(W) = \chi(W') = 1$ and suppose that $\vec{\gamma}_W|_M = \vec{\gamma}_{W'}|_M$. Then for each $k \geq 1$ there exists a constant $\mu_k \in \mathcal{A}_{2k,3k}$ such that*

$$Z_{2k,3k}^{\text{anomaly}}(\vec{\gamma}_W) - \mu_k \text{sign } W = Z_{2k,3k}^{\text{anomaly}}(\vec{\gamma}_{W'}) - \mu_k \text{sign } W'.$$

²This condition is not a generic one if $N \geq d + 2$. Thus this gives a stronger restriction than the transversality to the zero section. This restriction is placed to determine all the singularities.

Hence $Z_{2k,3k}^{\text{anomaly}}(\vec{\gamma}_W) - \mu_k \text{sign } W$ does not depend on the choice of $(W, \vec{\gamma}_W)$ such that $\partial W = M$, $\chi(W) = 1$, $\vec{\gamma}_W|_{M-U'_\infty} = -\text{grad } \vec{f}$.

Proof of Proposition 2.12 (1). Put $\vec{\gamma} = (\gamma_1, \dots, \gamma_{3k}) = \vec{\gamma}_W$. Since for the GM extension γ_i the singularity set $\Sigma(\gamma_i) = \gamma_i^{-1}(0)$ is a compact smooth 1-submanifold of a 4-manifold W , we may assume that $\Sigma(\gamma_i) \cap \Sigma(\gamma_j) = \emptyset$ if $i \neq j$, and moreover that they are separated by small open tubular neighborhoods. We shall show that the image of the projection of the 0-dimensional moduli space $\mathcal{M}_\Gamma^{\text{local}}(\vec{\gamma})$ on W is disjoint from a neighborhood of $\Sigma(\gamma_i)$ for each i and hence from a neighborhood of $\coprod_{j=1}^{3k} \Sigma(\gamma_j)$.

Let Γ' be the graph obtained from Γ by replacing $E(\Gamma)$ with $E(\Gamma) - \{\beta(i)\}$. According to Definition 2.7, $\mathcal{M}_{\Gamma'}^{\text{local}}(\vec{\gamma})$ is the intersection of $\mathcal{M}_{\Gamma'}^{\text{local}}(\vec{\gamma} \setminus \{\gamma_i\})$ with $\Theta_i(\gamma_i)$. By Lemma 2.8, $\mathcal{M}_{\Gamma'}^{\text{local}}(\vec{\gamma} \setminus \{\gamma_i\})$ is a submanifold of $(W - \bigcup_{j \neq i} \Sigma(\gamma_j)) \times \overline{C}_{2k}^{\text{local}}(\mathbb{R}^3)$ of codimension $2(3k - 1) = 6k - 2$, i.e., a 2-submanifold if $\vec{\gamma}$ is generic. For a generic choice of γ_i , the projection of $\mathcal{M}_{\Gamma'}^{\text{local}}(\vec{\gamma} \setminus \{\gamma_i\})$ on W is disjoint from a neighborhood of $\Sigma(\gamma_i)$ for a dimensional reason. Hence for a generic choice of γ_i , the projection of $\mathcal{M}_\Gamma^{\text{local}}(\vec{\gamma})$ on W is disjoint from a neighborhood of $\Sigma(\gamma_i)$. Here we may assume that the perturbation of γ_i for the disjunction has support in an arbitrarily small neighborhood of $\Sigma(\gamma_i)$. Since $\Sigma(\gamma_i) \cap \Sigma(\gamma_j) = \emptyset$ for $i \neq j$, the perturbations can be done for all i independently and we may assume that $\mathcal{M}_\Gamma^{\text{local}}(\vec{\gamma})$ is disjoint from a tubular neighborhood of $\coprod_{j=1}^{3k} \Sigma(\gamma_j)$.

By Lemma 2.8, the restriction of $\mathcal{M}_\Gamma^{\text{local}}(\vec{\gamma})$ to the complement of the tubular neighborhood of $\coprod_{j=1}^{3k} \Sigma(\gamma_j)$ is compact. Therefore, for a generic choice of $\vec{\gamma}$, $\mathcal{M}_\Gamma^{\text{local}}(\vec{\gamma})$ is a compact 0-submanifold, i.e., a finite set. \square

The proof of Proposition 2.12 (2) will be given in §7.2.

2.9. Main result and conjectures.

THEOREM 2.13. *For $k \geq 1$,*

$$\widehat{Z}_{2k,3k}(\vec{f}) = Z_{2k,3k}(\vec{f}) - Z_{2k,3k}^{\text{anomaly}}(\vec{\gamma}_W) + \mu_k \text{sign } W \in \mathcal{A}_{2k,3k},$$

where μ_k is the constant found in Proposition 2.12 (2), is an invariant of diffeomorphism type of M .

Proof of the theorem is given in §10. Theorem 2.13 allows us to write $\widehat{Z}_{2k,3k}(M) = \widehat{Z}_{2k,3k}(\vec{f})$. As mentioned in [Fuk2], the 2-loop part $Z_{2,3}(M)$ is likely to coincide with the 2-loop part of the configuration space integral of Kontsevich. The generalization of this conjecture is the following, which can be considered as a higher loop analogue of a theorem of Cheeger [Ch] and Müller [Mü].

CONJECTURE 2.14. $\widehat{Z}_{2k,3k}(M)$ agrees with Kuperberg–Thurston’s universal expression ([KT]) of the configuration space integral invariant of Kontsevich ([Ko]).

It is known that the configuration space integral invariant of Kontsevich recovers all \mathbb{Q} -valued Ohtsuki finite type invariants ([Oh, KT, Les2]). Shortly after the author proposed Conjecture 2.14 in an earlier version of this article, Shimizu gave a proof of Conjecture 2.14 ([Sh]). Shimizu also found an explicit relation of the constant μ_k to a constant δ_k considered in [KT, Les2] for configuration space integrals.

In [Fuk2], Fukaya obtained the leading term of a propagator by considering the limit of Witten’s deformed Laplacian and by deforming the propagator that Axelrod–Singer obtained by harmonic analysis in [AS]. Thus in a sense, Fukaya’s and our

construction is closer to that of [AS] than the general construction in [KT]. It would be very interesting to clarify a relationship between our construction and that of [AS], also in relation to part II. Also, it would be very interesting to see if the correction term in this paper is related to the correction term in [AS].

REMARK 2.15. (1) C. Lescop independently constructed in collaboration with G. Kuperberg ([Les3]) an explicit 4-chain in the configuration space of two points in a rational homology 3-sphere M by a geometric consideration about Heegaard diagrams, which is reminiscent of Heegaard Floer homology. She defined an invariant of ‘combings’ on M using the explicit 4-chain and gave a combinatorial formula for the invariant.

(2) M. Futaki pointed out in [Fut] some bifurcations that are missed in [Fuk2]. In [Fuk2], the coefficients in the linear combination of graphs are defined by contracting holonomies considered along flow graphs by \mathfrak{g} -invariant tensors. However, Futaki observed with a concrete computation that for some bifurcations, the holonomy matrix will suddenly jump and thus the invariance fails. Since we construct an invariant via an intersection theory considering only the trivial connection contribution, the coefficients in the linear combination in our definition can be given without using holonomy matrix, so the same problem does not occur. (See also Remark 2.3.)

3. Moduli space of gradient trajectories. We shall construct a compactification $\overline{\mathcal{M}}_2(f)$ of the space $\mathcal{M}_2(f)$ of gradient trajectories that corresponds to a compact edge in a graph, in a fashion similar to [BH]. The compactification $\overline{\mathcal{M}}_2(f)$ will play a fundamental role in defining the compactification $\overline{\mathcal{M}}_\Gamma(\vec{f})$. For a Morse function f and a metric μ on M_0 , we define

$$\mathcal{M}_2(f) = \mathcal{M}_2(f; \mu) = \{(x, y) \in (M_0 - \Sigma(f))^2; y = \Phi_f^t(x) \text{ for some } t > 0\}.$$

It follows from a property of solutions of ordinary differential equations that $\mathcal{M}_2(f)$ is a submanifold of $(M_0 - \Sigma(f))^2$ of dimension $d + 1$. We shall construct a natural compactification of $\mathcal{M}_2(f)$. Moreover, we obtain compactifications of $\mathcal{D}_p(f)$ and $\mathcal{S}_p(f)$ by using the compactification of $\mathcal{M}_2(f)$.

3.1. A decomposition of $\mathcal{M}_2(f)$. First we make some assumptions. In the following we assume that a Morse function f is chosen as in the following lemma.

LEMMA 3.1 (e.g. Lemma 2.8 of [Mi2]). *For any C^r Morse function $f : M_0 \rightarrow \mathbb{R}$ that is standard near ∞_M , there is an arbitrarily C^r -small perturbation of f in the subspace of $C_{\varphi_\infty}^r(M_0)$ of Morse functions such that all the critical values of the resulting Morse function are distinct. (Such a Morse function is said to be ordered.)*

The Morse lemma gives a local coordinate description of the moduli space. Let f be a Morse function on M_0 . By the Morse lemma, one can find a local coordinate (x_1, \dots, x_d) on a neighborhood M_p of a critical point p of f and a metric μ on M_0 such that f agrees on M_p with

$$h(x) = f(p) - \frac{x_1^2}{2} - \dots - \frac{x_i^2}{2} + \frac{x_{i+1}^2}{2} + \dots + \frac{x_d^2}{2} \quad (3.1)$$

and such that μ agrees with the Euclidean metric on M_p with respect to the coordinate (x_1, \dots, x_d) . We say that such a metric μ is *Euclidean near critical points*. We call a pair of M_p and the coordinate (x_1, \dots, x_d) a *Morse model*.

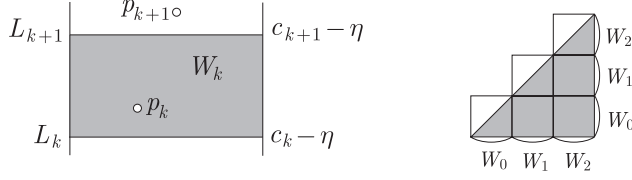

FIG. 4. W_k and a schematic illustration for a decomposition of $\mathcal{M}_2(f)$. This consists of 6 squares each corresponds to $\mathcal{M}_2(f; W_k, W_j)$.

Suppose that the singular set $\Sigma(f) = \{p_1, p_2, \dots, p_N\}$ is numbered so that $f(p_k) < f(p_{k+1})$ for each $k \leq N - 1$. We put $c_k = f(p_k)$. For a small number $\eta > 0$ and $1 \leq k \leq N - 1$, let

$$\begin{aligned} W_k &= f^{-1}[c_k - \eta, c_{k+1} - \eta] \cup \{\infty_M\}, & L_k &= f^{-1}(c_k - \eta) \cup \{\infty_M\}, \\ W_N &= f^{-1}[c_N - \eta, \infty) \cup \{\infty_M\}, & L_N &= f^{-1}(c_N - \eta) \cup \{\infty_M\}, \\ W_0 &= f^{-1}(-\infty, c_1 - \eta] \cup \{\infty_M\}. \end{aligned}$$

See Fig. 4. For a pair of subsets A, B of M , let $\mathcal{M}_2(f; A, B) = \mathcal{M}_2(f) \cap (A \times B)$. Then we have

$$\mathcal{M}_2(f) = \bigcup_{0 \leq j \leq k \leq N} \mathcal{M}_2(f; W_k, W_j).$$

For $0 \leq j \leq k \leq N$, there is a natural embedding

$$\psi_{kj} : \mathcal{M}_2(f; W_k, W_j) \rightarrow W_k \times L_k \times L_{k-1} \times \dots \times L_{j+1} \times W_j,$$

defined by $\psi_{kj}(x, y) = (x, z_k, z_{k-1}, \dots, z_{j+1}, y)$, where $z_i \in L_i$ is the unique intersection point of the flow line between x and y with L_i . Then $\mathcal{M}_2(f)$ is canonically diffeomorphic to the union of the images $\psi_{kj}(\mathcal{M}_2(f; W_k, W_j))$ ($0 \leq j \leq k \leq N$) glued together by the diffeomorphisms

$$\begin{aligned} \psi_{kj} \circ \psi_{k+1,j}^{-1} &: \psi_{k+1,j}(\mathcal{M}_2(f; L_{k+1}, W_j)) \rightarrow \psi_{kj}(\mathcal{M}_2(f; L_{k+1}, W_j)), \\ \psi_{kj} \circ \psi_{k,j-1}^{-1} &: \psi_{k,j-1}(\mathcal{M}_2(f; W_k, L_j)) \rightarrow \psi_{kj}(\mathcal{M}_2(f; W_k, L_j)). \end{aligned}$$

See Fig. 4. Note that $\psi_{kj} \circ \psi_{k+1,j}^{-1}$ and $\psi_{kj} \circ \psi_{k,j-1}^{-1}$ agree with the maps induced from the projections

$$\begin{aligned} \pi_{kj} : W_{k+1} \times L_{k+1} \times L_k \times \dots \times L_{j+1} \times W_j &\rightarrow W_k \times L_k \times L_{k-1} \times \dots \times L_{j+1} \times W_j, \\ (x, z_{k+1}, z_k, \dots, z_{j+1}, y) &\mapsto (z_{k+1}, z_k, z_{k-1}, \dots, z_{j+1}, y), \\ \rho_{kj} : W_k \times L_k \times L_{k-1} \times \dots \times L_j \times W_{j-1} &\rightarrow W_k \times L_k \times L_{k-1} \times \dots \times L_{j+1} \times W_j, \\ (x, z_k, z_{k-1}, \dots, z_j, y) &\mapsto (x, z_k, z_{k-1}, \dots, z_{j+1}, z_j). \end{aligned}$$

3.2. The definition of $\overline{\mathcal{M}}_2(f)$. Let

$$\overline{\mathcal{M}}_2(f; W_k, W_j) = \overline{\psi_{kj}(\mathcal{M}_2(f; W_k, W_j))} \quad (\text{the closure}). \tag{3.2}$$

Note that this is not the closure of $\mathcal{M}_2(f; W_k, W_j)$ in $W_k \times W_j$ when $k > j$, but the closure in the codomain of ψ_{kj} .

LEMMA 3.2. *The maps π_{kj} and ρ_{kj} induce diffeomorphisms*

$$\frac{\overline{\psi_{k+1,j}(\mathcal{M}_2(f; L_{k+1}, W_j))}}{\overline{\psi_{k,j-1}(\mathcal{M}_2(f; W_k, L_j))}} \rightarrow \frac{\overline{\psi_{kj}(\mathcal{M}_2(f; L_{k+1}, W_j))}}{\overline{\psi_{kj}(\mathcal{M}_2(f; W_k, L_j))}}.$$

Proof. We only give a proof for π_{kj} . The smoothness of π_{kj} is obvious. Define a smooth map $\gamma : L_{k+1} \times L_k \times \cdots \times L_{j+1} \times W_j \rightarrow L_{k+1} \times L_{k+1} \times L_k \times \cdots \times L_{j+1} \times W_j$ by $\gamma(x, z_k, \dots, z_{j+1}, y) = (x, x, z_k, \dots, z_{j+1}, y)$. The restriction of γ to $\overline{\psi_{k+1,j}(\mathcal{M}_2(f; L_{k+1}, W_j))}$ is the smooth inverse to π_{kj} . \square

DEFINITION 3.3. We define

$$\overline{\mathcal{M}}_2(f) = \bigcup_{0 \leq j \leq k \leq N} \overline{\mathcal{M}}_2(f; W_k, W_j), \quad (3.3)$$

where the pieces are glued together by the diffeomorphisms of Lemma 3.2.

It is clear from the definition that $\overline{\mathcal{M}}_2(f)$ is compact. Let

$$\bar{b} : \overline{\mathcal{M}}_2(f) \rightarrow M \times M$$

be the continuous map that extends the natural embedding $b = \bigcup_{k,j} \psi_{kj}^{-1} : \bigcup_{j,k} \psi_{kj}(\mathcal{M}_2(f; W_k, W_j)) \rightarrow M \times M$ onto $\overline{\mathcal{M}}_2(f)$. In other words, \bar{b} gives the pair of endpoints of a flow line (possibly broken. see below.). For subsets A of W_k and B of W_j , let

$$\overline{\mathcal{M}}_2(f; A, B) = \overline{\psi_{kj}(\mathcal{M}_2(f; A, B))} \subset A \times L_k \times \cdots \times L_{j+1} \times B. \quad (3.4)$$

This is consistent with (3.2). Note that this may depend on the choices of k and j when $A \subset L_k$ or $B \subset L_{j+1}$, but it becomes well-defined if it is considered as a subspace of $\overline{\mathcal{M}}_2(f)$.

For a Morse pair (f, μ) and a pair (x, y) of distinct points of $M_0 - \Sigma(f)$, a (r times) *broken flow line between x and y* is a sequence $\gamma_0, \gamma_1, \dots, \gamma_r$ ($r \geq 1$) of integral curves of $-\text{grad } f$ satisfying the following conditions:

- (1) The domain of γ_0 is $[0, \infty)$, the domain of γ_r is $(-\infty, 0]$ and the domain of γ_i , $1 \leq i \leq r-1$, is \mathbb{R} .
- (2) $\gamma_0(0) = x$, $\gamma_r(0) = y$.
- (3) There is a sequence q_1, q_2, \dots, q_r of distinct critical points of f such that $\lim_{s \rightarrow -\infty} \gamma_i(s) = \lim_{s \rightarrow \infty} \gamma_{i-1}(s) = q_i$ ($1 \leq i \leq r$).

A broken flow line $(\gamma_0, \gamma_1, \dots, \gamma_r)$ between x and y is determined up to reparametrizations by the boundary points x, y and intersection points of γ_i with level surfaces that lie between q_i and q_{i+1} . More precisely, a broken flow line between $x \in W_k$ and $y \in W_j$ is uniquely determined by a point of $W_k \times L_k \times \cdots \times L_{j+1} \times W_j$ up to reparametrizations and conversely a broken flow line between $x \in W_k$ and $y \in W_j$ determines a point of $W_k \times L_k \times \cdots \times L_{j+1} \times W_j$. So we may identify a broken flow line between $x \in W_k$ and $y \in W_j$ with a point of $W_k \times L_k \times \cdots \times L_{j+1} \times W_j$ and call the latter a *broken flow sequence*.

Now the main proposition of this subsection can be stated as follows³.

³We will not give explicit charts on every strata. The article [We] of K. Wehrheim gives a full description of the smooth structures on the compactification of $\mathcal{M}_2(f)$ and explicit associative gluing maps in a similar finite dimensional fashion as [BH].

PROPOSITION 3.4. *Let (f, μ) be a Morse–Smale pair on M_0 such that f is ordered and μ is Euclidean near critical points. Let $\Omega_M = (M \times \infty_M) \cup (\infty_M \times M)$, $\widehat{\Delta}_M = \Delta_M \cup \Omega_M$. Then $\overline{\mathcal{M}}_2(f)$ in (3.3) is compact and satisfies the following conditions.*

- (1) $\overline{\mathcal{M}}_2(f) - \bar{b}^{-1}(\widehat{\Delta}_M)$ is a smooth manifold with corners.
- (2) \bar{b} induces a diffeomorphism $\text{Int } \overline{\mathcal{M}}_2(f) \rightarrow \mathcal{M}_2(f)$.
- (3) The codimension r stratum of $\overline{\mathcal{M}}_2(f) - \bar{b}^{-1}(\widehat{\Delta}_M)$ consists of r times broken flow sequences. The codimension r stratum of $\overline{\mathcal{M}}_2(f) - \bar{b}^{-1}(\widehat{\Delta}_M)$ for $r \geq 1$ is canonically diffeomorphic to

$$\begin{cases} \mathcal{A}_{q_1}(f) \times \mathcal{D}_{q_1}(f) - \Delta_M & (r = 1) \\ \prod_{\substack{q_1, \dots, q_r \in \Sigma(f) \\ q_1, \dots, q_r \text{ distinct}}} \mathcal{A}_{q_1}(f) \times \mathcal{M}'(f; q_1, q_2) \times \dots \times \mathcal{M}'(f; q_{r-1}, q_r) \times \mathcal{D}_{q_r}(f) & (r \geq 2) \end{cases}$$

The proof is divided into §3.3, §3.4 and §3.5.

REMARK 3.5.

- (1) The compactification $\overline{\mathcal{M}}_2(f)$ may not be embedded by \bar{b} into $M \times M$ whereas $\mathcal{M}_2(f)$ is a submanifold of $M \times M$. The dimensions of some faces of the boundary of $\overline{\mathcal{M}}_2(f)$ decreases.
- (2) In fact, $\overline{\mathcal{M}}_2(f)$ is smooth on $\overline{\mathcal{M}}_2(f) - \bar{b}^{-1}(\widehat{\Delta}_{\Sigma(f)})$, where $\widehat{\Delta}_{\Sigma(f)} = \{(p, p) \in M \times M; p \in \Sigma(f) \cup \{\infty_M\}\}$. The boundary of $\overline{\mathcal{M}}_2(f)$ has conic singularities on $\bar{b}^{-1}(\widehat{\Delta}_{\Sigma(f)})$.
- (3) The definition of $\overline{\mathcal{M}}_2(f)$ depends on the choice of the level surfaces L_k . But its diffeomorphism type (as a manifold with corners) does not depend on the choice and it is enough for our purpose.

3.3. Smooth structure of the moduli space of short trajectories. Let h be the standard quadratic form of (3.1). First, we describe the standard model

$$\mathcal{M}_2(h) = \{(x, y) \in (\mathbb{R}^d)^2; y = \Phi_h^t(x) \text{ for some } t > 0\}.$$

The following lemma is a key lemma in the construction of the compactification.

LEMMA 3.6. $\mathcal{M}_2(h) = \{(\rho u, v) \times (u, \rho v); u \in \mathbb{R}^i, v \in \mathbb{R}^{d-i}, \rho \in (0, 1)\}$. Hence its closure $\overline{\mathcal{M}}_2(h)$ in $\mathbb{R}^d \times \mathbb{R}^d$ is

$$\overline{\mathcal{M}}_2(h) = \{(\rho u, v) \times (u, \rho v); u \in \mathbb{R}^i, v \in \mathbb{R}^{d-i}, \rho \in [0, 1]\}$$

and $\overline{\mathcal{M}}_2(h) - \{0 \times 0\}$ is a smooth manifold with boundary, with

$$\partial \overline{\mathcal{M}}_2(h) = (\{0\} \times \mathbb{R}^{d-i}) \times (\mathbb{R}^i \times \{0\}) \cup_{0 \times 0} \Delta_{\mathbb{R}^d} = (\mathcal{A}_0(h) \times \mathcal{D}_0(h)) \cup_{0 \times 0} \Delta_{\mathbb{R}^d}.$$

Proof. Let $\mathcal{X} = \{(\rho u, v) \times (u, \rho v); u \in \mathbb{R}^i, v \in \mathbb{R}^{d-i}, \rho \in (0, 1)\}$. Suppose that $(\rho u, v) \times (u, \rho v) \in \mathcal{X}$. The solution for the differential equation

$$\dot{\gamma}(t) = -(\text{grad } h)_{\gamma(t)}$$

is $\gamma(t) = (\gamma_1(0)e^t, \dots, \gamma_i(0)e^t, \gamma_{i+1}(0)e^{-t}, \dots, \gamma_d(0)e^{-t})$. If $\gamma(0) = (\rho u, v)$, then $\gamma(t) = (\rho ue^t, ve^{-t})$. The system of equations $\rho ue^t = u, ve^{-t} = \rho v$ has a unique solution $t \geq 0$ provided that $(u, v) \neq (0, 0)$, in which case $(\rho u, v) \times (u, \rho v) \in \mathcal{M}_2(h)$. If

$(u, v) = (0, 0)$, then $(\rho u, v) \times (u, \rho v) = (0, 0) \times (0, 0)$ and obviously this belongs $\mathcal{M}_2(h)$. Conversely, for $(u_0, v_0) \times (u_0 e^t, v_0 e^{-t}) \in \mathcal{M}_2(h)$ ($t \geq 0$), put $u = u_0 e^t$ and $v = v_0$. Then $(u_0, v_0) \times (u_0 e^t, v_0 e^{-t}) = (u e^{-t}, v) \times (u, v e^{-t}) \in \mathcal{X}$. This completes the proof of $\mathcal{X} = \mathcal{M}_2(h)$.

For the latter assertion, consider the smooth map $\varphi : [0, 1] \times \mathbb{R}^i \times \mathbb{R}^{d-i} \rightarrow \mathbb{R}^d \times \mathbb{R}^d$ defined by $\varphi(\rho, u, v) = (\rho u, v) \times (u, \rho v)$. Its Jacobian matrix is

$$J\varphi_{(\rho, u, v)} = \begin{pmatrix} u & \rho I & O \\ \mathbf{0} & O & I \\ \mathbf{0} & I & O \\ v & O & \rho I \end{pmatrix} \quad (3.5)$$

whose rank is $d + 1$ unless $(u, v) = (0, 0)$. Namely, φ is an immersion outside $[0, 1] \times 0 \times 0$. Note that $\varphi([0, 1] \times 0 \times 0) = \{0 \times 0\}$. Moreover, it is easy to check that $\overline{\mathcal{M}_2(h)} - \{0 \times 0\}$ is a submanifold with boundary. The boundary corresponds to the image from $\rho = 0, 1$. \square

LEMMA 3.7. *Let (f, μ) be as in Proposition 3.4 and let $1 \leq k \leq N - 1$. Then*

(i) $\overline{\mathcal{M}_2(f; W_k, W_k)} - \widehat{\Delta}_{W_k}$ ($\widehat{\Delta}_{W_k} = W_k^2 \cap \widehat{\Delta}_M$) is a submanifold of $W_k \times W_k$ with corners, with

$$\begin{aligned} \partial \overline{\mathcal{M}_2(f; W_k, W_k)} &= \left[(\mathcal{A}_{p_k}(f) \cap W_k) \times (\mathcal{D}_{p_k}(f) \cap W_k) \right] \cup_{(p_k, p_k)} \Delta_{W_k} \\ &\cup \mathcal{M}_2(f; W_k, L_k) \cup \mathcal{M}_2(f; L_{k+1}, W_k). \end{aligned}$$

(ii) $\overline{\mathcal{M}_2(f; W_k, L_k)} - \{\infty_M^2\}$ is a submanifold of $W_k \times L_k$ with corners, with

$$\begin{aligned} \partial \overline{\mathcal{M}_2(f; W_k, L_k)} &= \left[(\mathcal{A}_{p_k}(f) \cap W_k) \times (\mathcal{D}_{p_k}(f) \cap L_k) \right] \\ &\cup \mathcal{M}_2(f; L_{k+1}, L_k) \cup \Delta_{L_k}. \end{aligned}$$

(iii) $\overline{\mathcal{M}_2(f; L_{k+1}, L_k)} - \{\infty_M^2\}$ is a submanifold of $L_{k+1} \times L_k$ with corners, with

$$\partial \overline{\mathcal{M}_2(f; L_{k+1}, L_k)} = (\mathcal{A}_{p_k}(f) \cap L_{k+1}) \times (\mathcal{D}_{p_k}(f) \cap L_k)$$

(iv) $\overline{\mathcal{M}_2(f; L_{k+1}, W_k)} - \{\infty_M^2\}$ is a submanifold of $L_{k+1} \times W_k$ with corners, with

$$\begin{aligned} \partial \overline{\mathcal{M}_2(f; L_{k+1}, W_k)} &= \left[(\mathcal{A}_{p_k}(f) \cap L_{k+1}) \times (\mathcal{D}_{p_k}(f) \cap W_k) \right] \\ &\cup \mathcal{M}_2(f; L_{k+1}, L_k) \cup \Delta_{L_{k+1}}. \end{aligned}$$

Proof. Here we only prove (i). The other cases are the restrictions of this case. The part $\mathcal{M}_2(f; W_k, L_k) \cup \mathcal{M}_2(f; L_{k+1}, W_k)$ is the boundary of $\mathcal{M}_2(f; W_k, W_k)$. To study the other ends, we define $U_k \subset M_{p_k}$ by the condition

$$\begin{cases} -\varepsilon < -x_1^2 - \cdots - x_i^2 + x_{i+1}^2 + \cdots + x_d^2 < \varepsilon \\ (-x_1^2 - \cdots - x_i^2)(x_{i+1}^2 + \cdots + x_d^2) < \varepsilon \end{cases}$$

for a sufficiently small number $\varepsilon > 0$, where i is the index of p_k . The closure of $\mathcal{M}_2(f; U_k, U_k)$ in $U_k \times U_k$ is the restriction of $\overline{\mathcal{M}_2(h)}$ in Lemma 3.6. Let $\widetilde{U}_k \subset W_k$ be the open subset defined as the union of all the images of integral curves of $-\text{grad } f$ that intersect U_k . By extention by the flow of $-\text{grad } f$, one may see that the boundary

of the closure of $\mathcal{M}_2(f; \tilde{U}_k, \tilde{U}_k)$ in $\tilde{U}_k \times \tilde{U}_k$ consists of degenerate flow-lines coming from those in $\partial \overline{\mathcal{M}}_2(h)$ and flow-lines of $\partial(\tilde{U}_k \times \tilde{U}_k)$. Then $\overline{\mathcal{M}}_2(f; W_k, W_k)$ is the union of $\overline{\mathcal{M}}_2(f; \tilde{U}_k, \tilde{U}_k)$ and $\mathcal{M}_2(f; W_k - \mathcal{K}_k, W_k - \mathcal{K}_k)$, where $\mathcal{K}_k = \mathcal{A}_{p_k}(f) \cup \mathcal{D}_{p_k}(f)$. This completes the proof. \square

The following lemma is an analogue of Lemma 3.7.

LEMMA 3.8. *Let (f, μ) be as in Proposition 3.4. Then*

(i) $\overline{\mathcal{M}}_2(f; W_N, W_N) - \widehat{\Delta}_{W_N}$ is a submanifold of $W_N \times W_N$ with corners, with

$$\begin{aligned} \partial \overline{\mathcal{M}}_2(f; W_N, W_N) &= \left[(\mathcal{A}_{p_N}(f) \cap W_N) \times (\mathcal{D}_{p_N}(f) \cap W_N) \right] \cup_{(p_N, p_N)} \Delta_{W_N} \\ &\cup \mathcal{M}_2(f; W_N, L_N) \cup \bar{b}^{-1}(\infty_M \times W_N). \end{aligned}$$

(ii) $\overline{\mathcal{M}}_2(f; W_N, L_N) - \{\infty_M^2\}$ is a submanifold of $W_N \times L_N$ with corners, with

$$\begin{aligned} \partial \overline{\mathcal{M}}_2(f; W_N, L_N) &= \left[(\mathcal{A}_{p_N}(f) \cap W_N) \times (\mathcal{D}_{p_N}(f) \cap L_N) \right] \\ &\cup \bar{b}^{-1}(\infty_M \times L_N) \cup \Delta_{L_N}. \end{aligned}$$

(iii) $\overline{\mathcal{M}}_2(f; W_0, W_0) - \widehat{\Delta}_{W_0}$ is a submanifold of $W_0 \times W_0$ with corners, with

$$\partial \overline{\mathcal{M}}_2(f; W_0, W_0) = \bar{b}^{-1}(W_0 \times \infty_M) \cup \mathcal{M}_2(f; L_1, W_0) \cup \Delta_{W_0}.$$

(iv) $\overline{\mathcal{M}}_2(f; L_1, W_0) - \{\infty_M^2\}$ is a submanifold of $L_1 \times W_0$ with corners, with

$$\partial \overline{\mathcal{M}}_2(f; L_1, W_0) = \bar{b}^{-1}(L_1 \times \infty_M) \cup \Delta_{L_1}.$$

3.4. Smooth structure of the moduli space of long trajectories. Next, we shall prove the following lemma.

LEMMA 3.9. *Let (f, μ) be as in Proposition 3.4 and suppose that f has N critical points whose values are all distinct. Then $\overline{\mathcal{M}}_2(f; W_k, W_j) - \bar{b}^{-1}(\Omega_M)$ ($0 \leq j < k \leq N$, definition in (3.2)) is a submanifold of $W_k \times L_k \times L_{k-1} \times \cdots \times L_{j+1} \times W_j$ with corners. The codimension r stratum of $\overline{\mathcal{M}}_2(f; W_k, W_j)$ for $r \geq 1$ consists of $r - s$ times broken flow sequences ξ with s events in the following list happening.*

- The initial endpoint of ξ lies in ∂W_k .
- The terminal endpoint of ξ lies in ∂W_j .
- The initial endpoint of ξ agrees with ∞_M (only if $k = N$).
- The terminal endpoint of ξ agrees with ∞_M (only if $j = 0$).

In the following, we follow convention in Appendix A about smooth manifolds with corners. To prove Lemma 3.9, we shall prove the following lemma by induction on $k - j - 1$.

LEMMA 3.10. *Under the assumption of Lemma 3.9, for $k - j - 1 \geq 0$, the moduli space $\overline{\mathcal{M}}_2(f; W_k, L_{j+1}) - \bar{b}^{-1}(\Omega_M)$ is a submanifold of $W_k \times L_k \times L_{k-1} \times \cdots \times L_{j+1}$ with corners, whose codimension r stratum for $r \geq 1$ consists of $r - s$ times broken flow sequences ξ with s events in the following list happening.*

- The initial endpoint of ξ lies in ∂W_k .
- The initial endpoint of ξ agrees with ∞_M (if $k = N$).

For $k - j - 1 = 0$, Lemma 3.10 has been proved in Lemma 3.7. Let us consider the case $k - j - 1 = 1$, i.e. $\overline{\mathcal{M}}_2(f; W_k, L_{k-1})$. The moduli space $\mathcal{M}_2(f; W_k, L_{k-1})$ is identified with the fiber product $\mathcal{M}_2(f; W_k, L_k) \times_{L_k} \mathcal{M}_2(f; L_k, L_{k-1})$ that is the limit (pullback) of the diagram:

$$\mathcal{M}_2(f; L_k, L_{k-1}) \xrightarrow{i_1} L_k \xleftarrow{i_2} \mathcal{M}_2(f; W_k, L_k),$$

where $i_2 : \mathcal{M}_2(f; W_k, L_k) \rightarrow L_k$ and $i_1 : \mathcal{M}_2(f; L_k, L_{k-1}) \rightarrow L_k$ are maps induced from projections $\text{pr}_2 : W_k \times L_k \rightarrow L_k$ and $\text{pr}_1 : L_k \times L_{k-1} \rightarrow L_k$ respectively. It is easy to see that i_2 and i_1 are transversal and hence by Proposition A.2 the fiber product is a smooth manifold with boundary.

LEMMA 3.11. *Let (f, μ) be as in Proposition 3.4. Then the smooth extensions $\bar{i}_2 : \overline{\mathcal{M}}_2(f; W_k, L_k) \rightarrow L_k$ and $\bar{i}_1 : \overline{\mathcal{M}}_2(f; L_k, L_{k-1}) \rightarrow L_k$ of the projections i_2 and i_1 respectively are strata transversal on the complement of $\bar{b}^{-1}(\Omega_M)$. Hence the complement of $\infty_M \times L_k \times L_k \times L_{k-1}$ in the fiber product*

$$\overline{\mathcal{M}}_2(f; W_k, L_k) \times_{L_k} \overline{\mathcal{M}}_2(f; L_k, L_{k-1}) \subset W_k \times L_k \times L_k \times L_{k-1}$$

is a smooth manifold with corners, whose strata are as follows.

- (0) The codimension 0 stratum is $\mathcal{M}_2(f; \text{Int } W_k, L_k) \times_{L_k} \mathcal{M}_2(f; L_k, L_{k-1})$.
- (1) The codimension 1 stratum is the union of $\partial_1 \overline{\mathcal{M}}_2(f; W_k, L_k) \times_{L_k} \mathcal{M}_2(f; L_k, L_{k-1})$ and $\mathcal{M}_2(f; \text{Int } W_k, L_k) \times_{L_k} \partial_1 \overline{\mathcal{M}}_2(f; L_k, L_{k-1})$, where ∂_r denotes the codimension r stratum of the complement of $\bar{b}^{-1}(\Omega_M)$.
- (2) The codimension 2 stratum is $\partial_1 \overline{\mathcal{M}}_2(f; W_k, L_k) \times_{L_k} \partial_1 \overline{\mathcal{M}}_2(f; L_k, L_{k-1})$.

Proof. If either $z_k \in i_2(\mathcal{M}_2(f; W_k, L_k))$ or $z_k \in i_1(\mathcal{M}_2(f; L_k, L_{k-1}))$, then z_k is a regular value of one of i_2 and i_1 . Indeed, if for example $z_k = i_2(x, z_k) \in i_2(\mathcal{M}_2(f; W_k, L_k))$, then there is a small open neighborhood O of z_k in L_k such that $T_{z_k}O$ and the tangent space of the gradient line at x parametrizes $T_{(x, z_k)}\mathcal{M}_2(f; W_k, L_k)$. Obviously, $di_2 : T_{(x, z_k)}\mathcal{M}_2(f; W_k, L_k) \rightarrow T_{z_k}L_k = T_{z_k}O$ is surjective. This shows that \bar{i}_2 and \bar{i}_1 are transversal between a codimension 0 stratum and any strata.

If $z_k \in \bar{i}_2(\partial \overline{\mathcal{M}}_2(f; W_k, L_k) - \mathcal{M}_2(f; W_k, L_k))$ and $z_k \in \bar{i}_1(\partial \overline{\mathcal{M}}_2(f; L_k, L_{k-1}))$, then the images of the normal bundles of $\bar{i}_2^{-1}(z_k)$ in $\partial \overline{\mathcal{M}}_2(f; W_k, L_k)$ and of $\bar{i}_1^{-1}(z_k)$ in $\partial \overline{\mathcal{M}}_2(f; L_k, L_{k-1})$ under the differentials $d\bar{i}_2$ and $d\bar{i}_1$ agree with $T_{z_k}(\mathcal{D}_{p_k}(f) \cap L_k)$ and $T_{z_k}(\mathcal{A}_{p_{k-1}}(f) \cap L_k)$ respectively. Then by the Morse–Smale condition for (f, μ) , these images span $T_{z_k}L_k$. This shows that \bar{i}_2 and \bar{i}_1 are transversal between codimension 1 strata. Now the lemma follows by applying Proposition A.2. \square

The following lemma proves Lemma 3.10 for $k - j - 1 = 1$.

LEMMA 3.12. *Let (f, μ) be as in Proposition 3.4. Then*

$$\overline{\mathcal{M}}_2(f; W_k, L_{k-1}) = \text{pr} \left[\overline{\mathcal{M}}_2(f; W_k, L_k) \times_{L_k} \overline{\mathcal{M}}_2(f; L_k, L_{k-1}) \right], \quad (3.6)$$

where $\text{pr} : \overline{\mathcal{M}}_2(f; W_k, L_k) \times_{L_k} \overline{\mathcal{M}}_2(f; L_k, L_{k-1}) \rightarrow W_k \times L_k \times L_{k-1}$ is the embedding $(x, z_k, z_k, z_{k-1}) \mapsto (x, z_k, z_{k-1})$. Hence $\overline{\mathcal{M}}_2(f; W_k, L_{k-1}) - \bar{b}^{-1}(\Omega_M)$ is a smooth manifold with corners, whose strata are as follows.

- (0) The codimension 0 stratum is $\text{pr} \left[\mathcal{M}_2(f; \text{Int } W_k, L_k) \times_{L_k} \mathcal{M}_2(f; L_k, L_{k-1}) \right]$.

(1) *The codimension 1 stratum is the union of*

$$\begin{aligned} & \text{pr} \left[\partial_1 \overline{\mathcal{M}}_2(f; W_k, L_k) \times_{L_k} \mathcal{M}_2(f; L_k, L_{k-1}) \right] \text{ and} \\ & \text{pr} \left[\mathcal{M}_2(f; \text{Int } W_k, L_k) \times_{L_k} \partial_1 \overline{\mathcal{M}}_2(f; L_k, L_{k-1}) \right]. \end{aligned}$$

(2) *The codimension 2 stratum is* $\text{pr} \left[\partial_1 \overline{\mathcal{M}}_2(f; W_k, L_k) \times_{L_k} \partial_1 \overline{\mathcal{M}}_2(f; L_k, L_{k-1}) \right]$.

Proof. We first need to show that pr takes $\overline{\mathcal{M}}_2(f; W_k, L_k) \times_{L_k} \overline{\mathcal{M}}_2(f; L_k, L_{k-1})$ diffeomorphically onto its image because the map pr is smooth and there is a smooth section $\gamma : W_k \times L_k \times L_{k-1} \rightarrow W_k \times \Delta_{L_k} \times L_{k-1} \subset W_k \times L_k \times L_k \times L_{k-1}$ of pr .

Since $\overline{\mathcal{M}}_2(f; W_k, L_{k-1})$ is the closure of $\psi_{k,k-1}(\mathcal{M}_2(f; W_k, L_{k-1}))$ in $W_k \times L_k \times L_{k-1}$ and since γ gives a homeomorphism $W_k \times L_k \times L_{k-1} \approx W_k \times \Delta_{L_j} \times L_{k-1}$, it suffices to show that the closure of $\gamma(\psi_{k,k-1}(\mathcal{M}_2(f; W_k, L_{k-1}))) = \mathcal{M}_2(f; W_k, L_k) \times_{L_k} \mathcal{M}_2(f; L_k, L_{k-1})$ agrees with $\overline{\mathcal{M}}_2(f; W_k, L_k) \times_{L_k} \overline{\mathcal{M}}_2(f; L_k, L_{k-1})$ to see (3.6). This follows from Proposition A.4 because the codimension 0 stratum of the latter space agrees with the former one. \square

The following lemma completes the induction and proves Lemma 3.10.

LEMMA 3.13. *Under the assumption of Lemma 3.9, suppose that Lemma 3.10 holds true for $k-j-1 = p \leq N-3$. Then Lemma 3.10 holds true for $k-j-1 = p+1$.*

Proof. By assumption, the moduli space $\overline{\mathcal{M}}_2(f; W_k, L_{j+1}) - \bar{b}^{-1}(\Omega_M)$ is a smooth manifold with corners, whose strata are as described in Lemma 3.10. Then by exactly the same argument as in Lemmas 3.11 and 3.12, one may see the following.

(1) By Proposition A.2, the complement of $\bar{b}^{-1}(\Omega_M) \times L_{j+1} \times L_j$ in the fiber product $\overline{\mathcal{M}}_2(f; W_k, L_{j+1}) \times_{L_{j+1}} \overline{\mathcal{M}}_2(f; L_{j+1}, L_j) \subset (W_k \times L_k \times L_{k-1} \times \cdots \times L_{j+1}) \times (L_{j+1} \times L_j)$ has the structure of a smooth manifold with corners, whose codimension r stratum is the union of $\partial_r \overline{\mathcal{M}}_2(f; W_k, L_{j+1}) \times_{L_{j+1}} \mathcal{M}_2(f; L_{j+1}, L_j)$ and $\partial_{r-1} \overline{\mathcal{M}}_2(f; W_k, L_{j+1}) \times_{L_{j+1}} \partial_1 \overline{\mathcal{M}}_2(f; L_{j+1}, L_j)$.

(2) By Proposition A.4,

$$\overline{\mathcal{M}}_2(f; W_k, L_j) = \text{pr} \left[\overline{\mathcal{M}}_2(f; W_k, L_{j+1}) \times_{L_{j+1}} \overline{\mathcal{M}}_2(f; L_{j+1}, L_j) \right]$$

where $\text{pr} : (W_k \times L_k \times L_{k-1} \times \cdots \times L_{j+1}) \times (L_{j+1} \times L_j) \rightarrow W_k \times L_k \times L_{k-1} \times \cdots \times L_{j+1} \times L_j$ is the projection $(x, z_k, z_{k-1}, \dots, z_{j+1}, z_{j+1}, z_j) \mapsto (x, z_k, z_{k-1}, \dots, z_{j+1}, z_j)$, which embeds $\overline{\mathcal{M}}_2(f; W_k, L_{j+1}) \times_{L_{j+1}} \overline{\mathcal{M}}_2(f; L_{j+1}, L_j)$.

These observations complete the proof. \square

Proof of Lemma 3.9. By replacing $\overline{\mathcal{M}}_2(f; L_{j+1}, L_j)$ in the proof of Lemma 3.13 with $\overline{\mathcal{M}}_2(f; L_{j+1}, W_j)$, one may see by Proposition A.4 that $\overline{\mathcal{M}}_2(f; W_k, W_j)$ agrees with the projection of the fiber product $\overline{\mathcal{M}}_2(f; W_k, L_{j+1}) \times_{L_{j+1}} \overline{\mathcal{M}}_2(f; L_{j+1}, W_j)$ whose complement of $\bar{b}^{-1}(\Omega_M)$ is a smooth manifold with corners as desired. \square

3.5. Moduli space of general trajectories.

Proof of Proposition 3.4. Now we know from Lemma 3.9 that $\overline{\mathcal{M}}_2(f)$ is the union of moduli spaces $\overline{\mathcal{M}}_2(f; W_k, W_j)$ ($0 \leq j \leq k \leq N$) that are smooth manifolds with corners, glued together by diffeomorphisms of Lemma 3.2. The result is, outside $\bar{b}^{-1}(\bar{\Omega}_M)$, a smooth manifold with corners (see Lemma 3.7 for the reason of exclusion of the diagonal). This proves the property (1). The property (2) is immediate from the definition of $\overline{\mathcal{M}}_2(f)$.

Since the diffeomorphisms of Lemma 3.2 are strata preserving (Appendix A) in both directions, no new corners will appear under the gluing. The diffeomorphisms induce gluings between strata of the same codimensions and of the same type. For example, the component of r times broken flow sequences in $\overline{\mathcal{M}}_2(f, W_k, W_j)$ is glued together along $\overline{\mathcal{M}}_2(f; L_{k+1}, W_j)$ with the component of r times broken flow sequences in $\overline{\mathcal{M}}_2(f; W_{k+1}, W_j)$. This proves the property (3). \square

3.6. Compactifications of descending and ascending manifolds. Let (f, μ) be a Morse pair as in Proposition 3.4. For a critical point p of f , let

$$\overline{\mathcal{D}}_p(f) = \bar{b}^{-1}(p \times M), \quad \overline{\mathcal{A}}_p(f) = \bar{b}^{-1}(M \times p).$$

We obtain the following well-known result (e.g., [BH, Theorem 1]).

PROPOSITION 3.14. *Let (f, μ) be as in Proposition 3.4 and let p be a critical point of f . Then $\overline{\mathcal{D}}_p(f)$ (resp. $\overline{\mathcal{A}}_p(f)$) is a compactification of the descending manifold $\mathcal{D}_p(f)$ (resp. ascending manifold $\mathcal{A}_p(f)$) to a smooth manifold with corners whose codimension r stratum of $\overline{\mathcal{D}}_p(f) - \bar{b}^{-1}(p \times \infty_M)$ (resp. $\overline{\mathcal{A}}_p(f) - \bar{b}^{-1}(\infty_M \times p)$) for $r \geq 1$ is canonically diffeomorphic to*

$$\prod_{\substack{q_1, \dots, q_r \in \Sigma(f) \\ p, q_1, \dots, q_r \text{ distinct}}} \mathcal{M}'(f; p, q_1) \times \mathcal{M}'(f; q_1, q_2) \times \cdots \times \mathcal{M}'(f; q_{r-1}, q_r) \times \mathcal{D}_{q_r}(f)$$

(resp. $\prod_{\substack{q_1, \dots, q_r \in \Sigma(f) \\ p, q_1, \dots, q_r \text{ distinct}}} \mathcal{A}_{q_r}(f) \times \mathcal{M}'(f; q_r, q_{r-1}) \times \cdots \times \mathcal{M}'(f; q_2, q_1) \times \mathcal{M}'(f; q_1, p)$).

Proof. Suppose that the singular set $\Sigma(f) = \{p_1, \dots, p_N\}$ is numbered as in §3.1 and suppose that $p = p_k \in W_k \cap \Sigma(f)$ for some k . It follows from the definition of $\overline{\mathcal{M}}_2(f)$ that $\overline{\mathcal{D}}_p(f) \cap \bar{b}^{-1}(W_k \times W_k) = \overline{\mathcal{M}}_2(f; W_k, W_k) \cap (\{p\} \times W_k)$. By Lemma 3.7, the right hand side is equal to $\{p\} \times (\mathcal{D}_p(f) \cap W_k)$ since $\mathcal{M}_2(f; W_k, W_k) \cap (\{p\} \times W_k) = \emptyset$. Similarly, we have

$$\begin{aligned} \overline{\mathcal{D}}_p(f) \cap \bar{b}^{-1}(W_k \times W_j) &= \overline{\mathcal{M}}_2(f; W_k, W_j) \cap (\{p\} \times L_k \times \cdots \times L_{j+1} \times W_j) \\ &= \text{pr} \left[(\{p\} \times (\mathcal{D}_p(f) \cap L_k)) \times_{L_k} \overline{\mathcal{M}}_2(f; L_k, W_j) \right]. \end{aligned}$$

The descriptions of the strata in the statement follow from these identities and from Lemma 3.7, 3.8 and 3.9. The result for $\overline{\mathcal{A}}_p(f)$ is analogous. \square

4. Moduli space of flow graphs.

4.1. Transversality for \mathcal{M}_Γ . Let $\Gamma \in \mathcal{G}_{n, m, \vec{\eta}}^0(\vec{C})$ be a \vec{C} -colored graph with a inputs (and a outputs) without bivalent vertices. For simplicity, we assume that the noncompact edges in $\text{Se}(\Gamma)$ are labeled (via β) by $\{1, \dots, a\}$. Let p_i (resp. q_i) be a basis element attached on the input (resp. output) of the edge labeled i . We define a C^{r-1} -map $\Phi_{\vec{f}}: \prod_{j=1}^a (\mathcal{A}_{q_j}(f_j) \times \mathcal{D}_{p_j}(f_j)) \times M_0^n \times \mathbb{R}_{>0}^{m-a} \rightarrow M_0^{n+m+a}$ by

$$\begin{aligned} \Phi_{\vec{f}}(u_1, v_1, \dots, u_a, v_a; x_1, \dots, x_n; t_{a+1}, \dots, t_m) \\ = \prod_{i=1}^n (x_i, y_{k_1^i}, \dots, y_{k_{r_i}^i}, v_{\bar{k}_1^i}, \dots, v_{\bar{k}_{r_i}^i}, u_{\bar{\ell}_1^i}, \dots, u_{\bar{\ell}_{\bar{s}_i}^i}), \end{aligned}$$

where $y_k = \Phi_{f_k}^{t_k}(x_{\sigma(k)})$ and $\mathbb{R}_{>0} = (0, \infty)$ (see §2.4 for the symbols). Let $\Delta \subset M_0^{n+m+a}$ be the subset consisting of all the points of the form $\prod_{i=1}^n (x_i, \overbrace{x_i, \dots, x_i}^{r_i + \bar{r}_i + \bar{s}_i})$ for

$(x_1, \dots, x_n) \in M_0^n$. Then $\mathcal{M}_\Gamma(\vec{f})$ is the image of $\Phi_{\vec{f}}^{-1}(\Delta)$ under the projection onto M_0^n and the projection induces an embedding.

Let \mathcal{U}_j be a C^r -small neighborhood of a Morse function in the Banach manifold $C_{\varphi_\infty}^r(M_0)$ such that the cardinality of the set of critical points is constant on \mathcal{U}_j . By considering $\Phi_{\vec{f}}$ for all $\vec{f} \in \prod_{j=1}^m \mathcal{U}_j$ for a fixed Riemannian metric μ on M_0 , we get a smooth map

$$\Phi : \prod_{j=1}^a \bigcup_{f_j \in \mathcal{U}_j} (\mathcal{A}_{q_j}(f_j) \times \mathcal{D}_{p_j}(f_j)) \times M_0^n \times \mathbb{R}_{>0}^{m-a} \times \prod_{j=a+1}^m \mathcal{U}_j \rightarrow M_0^{n+m+a},$$

where we consider $\bigcup_{f_j \in \mathcal{U}_j} (\mathcal{A}_{q_j}(f_j) \times \mathcal{D}_{p_j}(f_j))$ as a subspace of $\mathcal{U}_j \times M_0^2$.

The proof of the following lemma is almost the same as [FO, Proposition 12.5]. (See [Wa1] for detail with our notations.)

LEMMA 4.1. *The smooth map Φ is transversal to Δ .*

Proof of Proposition 2.4. It follows from Lemma 4.1 that $\Phi^{-1}(\Delta)$ is a (infinite dimensional) submanifold of codimension $(n + m + a - n)d = (m + a)d$. Let $\pi : \Phi^{-1}(\Delta) \rightarrow \prod_{j=1}^m \mathcal{U}_j$ be the restriction of the projection. Since the dimension of the fiber of the projection

$$\prod_{j=1}^a \bigcup_{f_j \in \mathcal{U}_j} (\mathcal{A}_{q_j}(f_j) \times \mathcal{D}_{p_j}(f_j)) \times M_0^n \times \mathbb{R}_{>0}^{m-a} \times \prod_{j=a+1}^m \mathcal{U}_j \rightarrow \prod_{j=1}^m \mathcal{U}_j$$

is $\sum_{j=1}^a (i(p_j) + (d - i(q_j))) + nd + (m - a) = nd + ad + m - a + \sum_{j=1}^a \eta_j$, the index of the projection π is

$$nd + ad + m - a + \sum_{j=1}^a \eta_j - (m + a)d = (n - m)d + \sum_{j=1}^m \eta_j.$$

Hence for a regular value $\vec{f} \in \prod_{j=1}^m \mathcal{U}_j$ of π , the fiber of π is a smooth manifold of dimension $(n - m)d + \sum_{j=1}^m \eta_j$. By the Sard–Smale theorem ([Sm]), the set of regular values of π is residual. The second statement follows from the fact that there are only finitely many graphs in $\mathcal{G}_{m,n,\vec{\eta}}(\vec{C})$ for a fixed triple $m, n, \sum_{j=1}^m \eta_j$ and that a finite intersection of residual subsets is residual too. \square

4.2. Compactification of $C_n(M)$ of Fulton–MacPherson. This part is almost a copy from a part of [Wa]. For a closed d -manifold M , the configuration space $C_n(M)$ is a submanifold of M^n , that is the complement of the closed subset

$$\Sigma = \{(x_1, \dots, x_n) \in M^n; x_i = x_j \text{ for some } i \neq j \text{ or } x_i = \infty_M \text{ for some } i\} \subset M^n.$$

There is a natural filtration $\Sigma = \Sigma_n \supset \dots \supset \Sigma_2 \supset \Sigma_1$ with

$$\Sigma_j = \{(x_1, \dots, x_n) \in M^n; \#\{x_1, \dots, x_n, \infty_M\} \leq j\}.$$

The difference $\Sigma_{i+1} - \Sigma_i$ is a disjoint union of submanifolds of $M^n - \Sigma_i$. This property allows one to iterate (real) blow-ups along the filtration from the deepest one: First, one can consider the blow-up $B\ell(M^n, \Sigma_1)$ along the 0-submanifold $\Sigma_1 = \{(\infty_M, \dots, \infty_M)\}$ of M^n . Recall that a blow-up replaces a submanifold with

its normal sphere bundle. Since the closure of $\Sigma_2 - \Sigma_1$ in $B\ell(M^n, \Sigma_1)$ is also a disjoint union of smooth submanifolds (with boundaries), one can apply another blow-up along it, and so on. After the blow-ups along all the strata of Σ of codimension ≥ 1 , one obtains a smooth compact manifold with corners $\overline{C}_n(M)$.

We will need a precise description of the boundary of $\overline{C}_n(M)$ in the proof of invariance of $\widehat{Z}_{2k,3k}$, so we shall briefly recall it here. The space $\overline{C}_n(M)$ has a natural stratification corresponding to bracketings of the $n + 1$ letters $1, 2, \dots, n, \infty$, e.g., $((137)(25))46\infty$ (see [FM, AS, Ko, BT]). Roughly speaking, a pair of brackets corresponds to a face created by one blow-up. For example, the face corresponding to $((137)(25))46\infty$ is obtained by a sequence of blow-ups corresponding to a sequence $1234567\infty \rightarrow (12357)46\infty \rightarrow ((137)(25))46\infty$.

The codimension one (boundary) strata of $\overline{C}_n(M)$ correspond to bracketings of the form $(\dots)\dots$, with only one pair of brackets. For example, the stratum $\partial_{\{1, \dots, j\}}\overline{C}_n(M)$ of $\partial\overline{C}_n(M)$ corresponding to the bracketings $(12\dots j)j + 1 \dots n$ is the face created by the blow-up along the closure of the submanifold

$$\Delta_j = \{(x_1, \dots, x_n) \in M^n; x_1 = \dots = x_j, \text{ otherwise distinct}\} \subset M^n$$

in the result of the previous blow-ups. More precisely, $\partial_{\{1, \dots, j\}}\overline{C}_n(M)$ can be naturally identified with the blow-ups of the total space of the normal $S^{(j-1)d-1}$ -bundle of $\Delta_j \subset M^n$ along the intersection with the closures of deeper diagonals that correspond to deeper bracketings. The fiber of the normal $S^{(j-1)d-1}$ -bundle over a point $(x_j, \dots, x_n) \in \Delta_j$ is $(\{(0, y_2, \dots, y_j) \in (\mathbb{R}^d)^j\} - \{0\})/(\text{dilation}) \cong S^{(j-1)d-1}$, where the coordinate y_i corresponds to $x_i - x_1$ (where it makes sense) under the geodesic coordinate from a framing of $T_{x_j}M$. The stratum $\partial_{\{1, \dots, j\}}\overline{C}_n(M)$ is a fiber bundle over Δ_j . We denote the fiber of $\partial_{\{1, \dots, j\}}\overline{C}_n(M)$ over a point of Δ_j by $C_j^{\text{local}}(\mathbb{R}^d)$. As done in §2.7, we identify $C_j^{\text{local}}(\mathbb{R}^d)$ with the subset of $C_j(\mathbb{R}^d)$, as

$$C_j^{\text{local}}(\mathbb{R}^d) = \left\{ (y_1, \dots, y_j) \in C_j(\mathbb{R}^d); y_1 = 0, \sum_{\ell=2}^j \|y_\ell\|^2 = 1 \right\}.$$

We denote by $\overline{C}_j^{\text{local}}(\mathbb{R}^d)$ the closure of the image of the inclusion $C_j^{\text{local}}(\mathbb{R}^d) \hookrightarrow \overline{C}_j(\mathbb{R}^d)$, which is compact. The base space Δ_j is naturally diffeomorphic to $\overline{C}_{n-j+1}(M)$ and we denote by $\text{pr}_j : \Delta_j \rightarrow M$ the projection $(x_j, \dots, x_n) \mapsto x_j$. So $\partial_{\{1, \dots, j\}}\overline{C}_n(M)$ has the structure of the pullback of the associated $\overline{C}_j^{\text{local}}(\mathbb{R}^d)$ -bundle of TM ($\overline{C}_j^{\text{local}}(\mathbb{R}^d)$ is an SO_d -space) pulled back by pr_j . The definition of $\partial_A\overline{C}_n(M)$ for general subset $A \subset \{1, \dots, n, \infty\}$ corresponding to the bracketing $(A)A^c$ is similar.

4.3. Compactification of the moduli space \mathcal{M}_Γ .

Proof of Proposition 2.5. Let $\vec{f} = (f_1, f_2, \dots, f_{3k})$ and $\vec{\mu} = (\mu_1, \mu_2, \dots, \mu_{3k})$ be sequences of Morse functions and metrics on M_0 respectively such that for each i the pair (f_i, μ_i) is Morse–Smale and that μ_i is Euclidean near $\Sigma(f_i)$ with respect to the coordinates of the Morse lemma. We assume that the gradients of f_i are taken for μ_i . We shall construct a compactification $\overline{\mathcal{M}}_\Gamma(\vec{f})$ of $\mathcal{M}_\Gamma(\vec{f})$.

For $p, q \in \Sigma(f)$, let

$$\mathcal{N}_{pq}(f) = \mathcal{A}_q(f) \times \mathcal{D}_p(f), \quad \overline{\mathcal{N}}_{pq}(f) = \overline{\mathcal{A}}_q(f) \times \overline{\mathcal{D}}_p(f).$$

For $j \in \{1, 2, \dots, 3k\}$, let

$$Q_j = \begin{cases} \overline{\mathcal{M}}_2(f_j) & \text{if } \beta(j) \in \text{Comp}(\Gamma) \\ \overline{\mathcal{N}}_{pq}(f_j) & \text{if } \beta(j) \in \text{Se}(\Gamma) \text{ with input } p, \text{ output } q. \end{cases}$$

For $i \in \{1, 2, \dots, 2k\}$, let $j_1, j_2, j_3 \in \{1, 2, \dots, 3k\}$ be the labels of the edges which are incident to the i -th vertex of Γ . We define a smooth map $G_i : Q_{j_1} \times Q_{j_2} \times Q_{j_3} \rightarrow M \times M \times M$ as follows. Let $\bar{b}_{ji} : Q_j \rightarrow M$ be defined by

$$\bar{b}_{ji} = \begin{cases} \text{pr}_1 \circ \bar{b} & \text{if } i = \sigma(j) \\ \text{pr}_2 \circ \bar{b} & \text{if } i = \tau(j) \end{cases}$$

Then we define $G_i = \bar{b}_{j_1 i} \times \bar{b}_{j_2 i} \times \bar{b}_{j_3 i}$. Let $\widehat{G}_i : \prod_{j=1}^{3k} Q_j \rightarrow M^3$ be the composition $G_i \circ \text{proj} : \prod_{j=1}^{3k} Q_j \rightarrow Q_{j_1} \times Q_{j_2} \times Q_{j_3} \rightarrow M \times M \times M$. Let $\Delta_3 = \{(x, x, x); x \in M\}$. We define

$$\overline{\mathcal{M}}_\Gamma^\times(\vec{f}) = \bigcap_{i=1}^{2k} \widehat{G}_i^{-1}(\Delta_3).$$

The restriction of $\overline{\mathcal{M}}_\Gamma^\times(\vec{f})$ to $\prod_{j=1}^{3k} \text{Int } Q_j$ is canonically identified with $\mathcal{M}_\Gamma(\vec{f})$, which is a smooth manifold. Let $\bar{b}_\Gamma : \overline{\mathcal{M}}_\Gamma^\times(\vec{f}) \rightarrow M^{2k}$ be the map that assigns the positions of $2k$ trivalent vertices of a flow graph in M .

Now we consider the case where $\dim \mathcal{M}_\Gamma(\vec{f}) \leq 1$.

If $\dim \mathcal{M}_\Gamma(\vec{f}) = 0$, then $\overline{\mathcal{M}}_\Gamma^\times(\vec{f}) = \mathcal{M}_\Gamma(\vec{f}) \subset \prod_{j=1}^{3k} \text{Int } Q_j$ is a finite set. In this case $\overline{\mathcal{M}}_\Gamma(\vec{f}) = \overline{\mathcal{M}}_\Gamma^\times(\vec{f})$ is as desired.

If $\dim \mathcal{M}_\Gamma(\vec{f}) = 1$, then $\overline{\mathcal{M}}_\Gamma^\times(\vec{f})$ may have nonempty intersection with $\partial(\prod_{j=1}^{3k} Q_j)$. By Proposition 3.4 and Corollary A.3, the intersection of $\overline{\mathcal{M}}_\Gamma^\times(\vec{f})$ with $\partial(\prod_{j=1}^{3k} Q_j)$ consists of flow graphs of the following forms.

- (1) There is one edge that is a once broken flow line.
- (2) A set of edges is collapsed to a finite subset of M .

Here, we may assume that the intersection has no flow graphs broken more than once by perturbing the function f_j for the broken edge slightly. On a neighborhood of a point of $\overline{\mathcal{M}}_\Gamma^\times(\vec{f})$ of type (1), $\overline{\mathcal{M}}_\Gamma^\times(\vec{f})$ restricts to a smooth 1-manifold with boundary. On a neighborhood of a point of $\overline{\mathcal{M}}_\Gamma^\times(\vec{f})$ of type (2), $\overline{\mathcal{M}}_\Gamma^\times(\vec{f})$ may have singularities on the boundary and may not be a smooth manifold. There may be non-unique collapses of a subgraph to the same degenerate graph. In fact, it is the cone over finitely many points whose cone point lies on $\partial(\prod_{j=1}^{3k} Q_j)$, by the strata transversality near the boundary.

The conic singularity can be resolved by a sequence of blow-ups of $\overline{\mathcal{M}}_\Gamma^\times(\vec{f})$ analogous to the compactification of $C_{2k}(M)$ in §4.2, as follows. Let $N_{\Sigma_1} \subset M^{2k}$ be a small tubular neighborhood of the highest codimension stratum Σ_1 of Σ . Its preimage $\widehat{N}_{\Sigma_1} = \bar{b}_\Gamma^{-1}(N_{\Sigma_1}) \subset \overline{\mathcal{M}}_\Gamma^\times(\vec{f})$ is a subspace of small graphs concentrated near ∞_M . The restriction of \bar{b}_Γ to \widehat{N}_{Σ_1} is a topological embedding of a cone. Hence the blow-up of M^{2k} along Σ_1 replaces $\bar{b}_\Gamma(\widehat{N}_{\Sigma_1})$ with a smooth 1-manifold $Bl(\bar{b}_\Gamma(\widehat{N}_{\Sigma_1}), \Sigma_1)$ with boundary. By identifying $\widehat{N}_{\Sigma_1} - \bar{b}_\Gamma^{-1}(\Sigma_1)$ with $\text{Int } Bl(\bar{b}_\Gamma(\widehat{N}_{\Sigma_1}), \Sigma_1)$ through \bar{b}_Γ , we obtain a space

$$\overline{\mathcal{M}}_\Gamma^\times(\vec{f})[1] = (\overline{\mathcal{M}}_\Gamma^\times(\vec{f}) - \bar{b}_\Gamma^{-1}(\Sigma_1)) \cup_{\bar{b}_\Gamma} Bl(\bar{b}_\Gamma(\widehat{N}_{\Sigma_1}), \Sigma_1).$$

The singularities on $\bar{b}_\Gamma^{-1}(\Sigma_1)$ have been resolved. Next, we resolve the singularities on $\bar{b}_\Gamma^{-1}(\Sigma_2)$. Let $N_{\Sigma_2} \subset M^{2k}$ be a small tubular neighborhood of $\Sigma_2 - \Sigma_1$. We may assume that there is no edge of broken flow line in the flow graphs of $\overline{\mathcal{M}}_\Gamma^\times(\vec{f})[1] \cap \bar{b}_\Gamma^{-1}(N_{\Sigma_2})$. Its preimage $\widehat{N}_{\Sigma_2} = \bar{b}_\Gamma^{-1}(N_{\Sigma_2}) \subset \overline{\mathcal{M}}_\Gamma^\times(\vec{f})[1]$ is a subspace with a small subgraph with $2k - 1$ vertices. The restriction of \bar{b}_Γ to \widehat{N}_{Σ_2} is a topological embedding. Hence the blow-up of $Bl(M^{2k}, \Sigma_1)$ along the closure of $\Sigma_2 - \Sigma_1$ replaces $\bar{b}_\Gamma(\widehat{N}_{\Sigma_2})$ with a smooth manifold $Bl(\bar{b}_\Gamma(\widehat{N}_{\Sigma_2}), \Sigma_2)$ with corners. By identifying $\widehat{N}_{\Sigma_2} - \bar{b}_\Gamma^{-1}(\Sigma_2)$ with $\text{Int } Bl(\bar{b}_\Gamma(\widehat{N}_{\Sigma_2}), \Sigma_2)$ through \bar{b}_Γ , we obtain

$$\overline{\mathcal{M}}_\Gamma^\times(\vec{f})[2] = (\overline{\mathcal{M}}_\Gamma^\times(\vec{f})[1] - \bar{b}_\Gamma^{-1}(\Sigma_2)) \cup_{\bar{b}_\Gamma} Bl(\bar{b}_\Gamma(\widehat{N}_{\Sigma_2}), \Sigma_2).$$

Repeating in this way for $\Sigma_3, \dots, \Sigma_{2k}$, we obtain spaces $\overline{\mathcal{M}}_\Gamma^\times(\vec{f})[3], \dots, \overline{\mathcal{M}}_\Gamma^\times(\vec{f})[2k]$. We set $\overline{\mathcal{M}}_\Gamma(\vec{f}) = \overline{\mathcal{M}}_\Gamma^\times(\vec{f})[2k]$. By definition this is a compactification of $\mathcal{M}_\Gamma(\vec{f})$ as desired in Proposition 2.5. \square

REMARK 4.2. By abuse of notation, we denote by $\bar{b}_\Gamma : \overline{\mathcal{M}}_\Gamma(\vec{f}) \rightarrow \overline{\mathcal{C}}_{2k}(M)$ the natural map that assigns the positions of $2k$ trivalent vertices of a flow graph in M . In general, \bar{b}_Γ may not be an embedding but only an immersion if $\dim \overline{\mathcal{M}}_\Gamma(\vec{f}) = 1$.

5. (Co)orientations of the moduli spaces. Let $f : M_0 \rightarrow \mathbb{R}$ be a Morse function and μ be a metric on M_0 that is Morse–Smale and that is Euclidean near critical points with respect to the local coordinate of the Morse lemma. We shall fix (co)orientations of the trajectory spaces and describe the induced coorientations at the boundaries. The results in this section also hold for usual Morse functions and metrics on M .

5.1. Convention for (co)orientations of trajectory spaces. In the following we follow the orientation convention of Appendix B. Let $o(M) \in \Gamma(\bigwedge^d T^*M)$ denote a d -form representing the orientation of M . The trajectory space $\mathcal{M}_2(f)$ is the image of the embedding $\varphi : (M_0 - \Sigma(f)) \times (0, \infty) \rightarrow (M_0 - \Sigma(f))^2$ given by $\varphi(x, t) = (x, \Phi_f^t(x))$. If $x \in M_0 - \Sigma(f)$ and if $y = \Phi_f^T(x)$, we define

$$o(\mathcal{M}_2(f))_{(x,y)} = d\varphi_*(o(M)_x \wedge dT),$$

where $d\varphi_*$ is the map corresponding to $d\varphi : T((M_0 - \Sigma(f)) \times (0, \infty)) \rightarrow T(M \times M)$.

We orient $M \times M$ by $o(M \times M)_{(x,y)} = o(M)_y \wedge o(M)_x$. Then the coorientation $o_{M \times M}^*(\mathcal{M}_2(f))$ of $\mathcal{M}_2(f)$ in $M \times M$ is determined by

$$o_{M \times M}^*(\mathcal{M}_2(f))_{(x,y)} = *o(\mathcal{M}_2(f))_{(x,y)}.$$

We orient $\mathcal{N}_{pq}(f) = \mathcal{A}_q(f) \times \mathcal{D}_p(f) \subset M \times M$ by giving the coorientation

$$o_{M \times M}^*(\mathcal{N}_{pq}(f))_{(x,x')} = o_M^*(\mathcal{A}_q(f))_x \wedge o_M^*(\mathcal{D}_p(f))_{x'},$$

where $o_M^*(\mathcal{A}_q(f))_x$ and $o_M^*(\mathcal{D}_p(f))_{x'}$ are the ones determined by $o(\mathcal{D}_p(f))$ and $o(\mathcal{A}_q(f))$ respectively fixed in §2.4.

5.2. (Co)orientations induced on the boundaries of descending and ascending manifolds. For a Morse–Smale pair (f, μ) and its critical points p, q , we shall describe the induced (co)orientations of the faces $\mathcal{F}_r \overline{\mathcal{D}}_p(f)$ (resp. $\mathcal{F}_r \overline{\mathcal{A}}_q(f)$) of $\partial_1 \overline{\mathcal{D}}_p(f)$ (resp. $\partial_1 \overline{\mathcal{A}}_q(f)$) of flow lines broken at a critical point r , which are induced from the (co)orientation of $\mathcal{D}_p(f)$ (resp. $\mathcal{A}_p(f)$).

We consider coorientations of the faces $\mathcal{F}_r \overline{\mathcal{D}}_p(f)$ and $\mathcal{F}_r \overline{\mathcal{A}}_q(f)$ as follows. Let $\bar{b} : \overline{\mathcal{D}}_p(f) \rightarrow M$ be the map that assigns to each (possibly broken) flow sequence the terminal endpoint. If $i(p) - i(r) = 1$ and if a is a point of M that is the image of \bar{b} from a once broken flow sequence \hat{a} in $\partial_1 \overline{\mathcal{D}}_p(f)$ broken at a critical point $r \in \Sigma(f)$, then by Proposition 3.14 there is an open neighborhood N_a of a in M such that $\bar{b}^{-1}(N_a)$ is a disjoint union of finitely many half-disks whose set of components naturally corresponds to the finite set $\mathcal{M}'(f; p, r)$. Let $\widehat{N}_{\hat{a}}$ be the component of $\bar{b}^{-1}(N_a)$ on which \hat{a} lies. The restriction of \bar{b} to $\widehat{N}_{\hat{a}}$ is an embedding and hence the coorientation of $\partial_1 \overline{\mathcal{D}}_p(f)$ at a in M makes sense by identifying $\widehat{N}_{\hat{a}}$ with $\bar{b}(\widehat{N}_{\hat{a}})$. The same is also true for $\partial_1 \overline{\mathcal{A}}_q(f)$ at a once broken flow sequence broken at $r \in \Sigma(f)$ such that $i(r) - i(q) = 1$.

Note that $\text{Int } \bar{b}(\widehat{N}_{\hat{a}})$ is an open subset of $\mathcal{D}_p(f)$ and its closure in N_a is $\bar{b}(\widehat{N}_{\hat{a}})$. Hence the (co)orientation of $\mathcal{D}_p(f)$ induces a (co)orientation of the boundary $\partial \bar{b}(\widehat{N}_{\hat{a}})$ at a . We define $o_M^*(\partial_1 \overline{\mathcal{D}}_p(f))_a$ to be the one induced in this way. We also define $o_M^*(\partial_1 \overline{\mathcal{A}}_q(f))_a$ similarly.

LEMMA 5.1. *Under the assumption above, let p, r be critical points of f such that $f(p) > f(r)$ and $i(p) - i(r) = 1$. Let N_a and $a \in \bar{b}(\widehat{N}_{\hat{a}})$ be as above. Let b be a point of $\mathcal{M}'(f; p, r)$ such that the component $\widehat{N}_{\hat{a}}$ corresponds to b . Then the following identity in $\bigwedge^\bullet T_a^* M$ holds.*

$$o_M^*(\partial_1 \overline{\mathcal{D}}_p(f))_a = (-1)^{i(r)} \varepsilon_f(p, r)_b o_M^*(\mathcal{D}_r(f))_a.$$

Proof. Put $i = i(r)$. By assumptions $f(p) > f(r)$ and $i(p) - i(r) = 1$, the index of r is in $0 \leq i(r) \leq d - 1$. It suffices to check the assertion for one broken flow line. By Morse Lemma there is a local coordinate (x_1, \dots, x_d) around r on which f agrees with $f(r) - \frac{x_1^2}{2} - \dots - \frac{x_i^2}{2} + \frac{x_{i+1}^2}{2} + \dots + \frac{x_d^2}{2}$. In this coordinate, $\mathcal{D}_r(f)$ agrees with $\{(x_1, \dots, x_d) \in \mathbb{R}^d; x_{i+1} = \dots = x_d = 0\}$ and $\mathcal{A}_r(f)$ agrees with $\{(x_1, \dots, x_d) \in \mathbb{R}^d; x_1 = \dots = x_i = 0\}$. We may put

$$o(\mathcal{D}_r(f)) = \beta dx_1 \cdots dx_i \quad (\beta = \pm 1).$$

We may assume without loss of generality that $\mathcal{D}_p(f)$ agrees with $\{(x_1, \dots, x_d) \in \mathbb{R}^d; x_{i+1} = \dots = x_{d-1} = 0, x_d > 0\}$ in a neighborhood of r and we may put

$$o(\mathcal{D}_p(f)) = \alpha dx_1 \cdots dx_i dx_d \quad (\alpha = \pm 1).$$

Moreover we may assume that $a = (a_1, 0, \dots, 0)$ for some $a_1 \geq 0$. Then $\bar{b}(\widehat{N}_{\hat{a}})$ agrees with $\{(x_1, \dots, x_d) \in \mathbb{R}^d; x_{i+1} = \dots = x_{d-1} = 0, x_d \geq 0\} \cap N_a$ on N_a and

$$o(\partial \bar{b}(\widehat{N}_{\hat{a}}))_a = \iota \left(-\frac{\partial}{\partial x_d} \right) \alpha dx_1 \cdots dx_i dx_d = (-1)^{i+1} \alpha dx_1 \cdots dx_i = (-1)^{i+1} \alpha \beta o(\mathcal{D}_r(f))_a.$$

On the other hand, by assumption we have

$$\begin{aligned} o_M^*(\mathcal{D}_p(f))_b &= (-1)^{d-1-i} \alpha dx_{i+1} \cdots dx_{d-1}, \\ o_M^*(\mathcal{A}_r(f))_b &= * \beta dx_{i+1} \cdots dx_d = (-1)^{i(d-i)} \beta dx_1 \cdots dx_i \end{aligned}$$

for $b = (0, \dots, 0, b_d)$, $b_d > 0$. Hence

$$\begin{aligned} o_M^*(\mathcal{D}_p(f))_b \wedge o_M^*(\mathcal{A}_r(f))_b &= (-1)^{di+d-1} \alpha \beta dx_{i+1} \cdots dx_{d-1} dx_1 \cdots dx_i \\ &= (-1)^{d-1} \alpha \beta dx_1 \cdots dx_{d-1} = -\alpha \beta \iota \left(-\frac{\partial}{\partial x_d} \right) dx_1 \cdots dx_d \end{aligned}$$

and $\varepsilon_f(p, r)_b = -\alpha\beta$. This together with the equality above, we obtain the desired identity $o(\partial\bar{b}(\widehat{N}_{\hat{a}}))_a = (-1)^i \varepsilon_f(p, r)_b o(\mathcal{D}_r(f))_a$. \square

LEMMA 5.2. *Under the assumption above, let q, r be critical points of f such that $f(q) < f(r)$ and $i(r) - i(q) = 1$. Let N_a and $a \in \bar{b}(\widehat{N}_{\hat{a}})$ be as above. Let b be a point of $\mathcal{M}'(f; r, q)$ such that $\widehat{N}_{\hat{a}}$ corresponds to b . Then the following identity in $\bigwedge^\bullet T_a^*M$ holds.*

$$o_M^*(\partial_1 \overline{\mathcal{A}}_q(f))_a = -\varepsilon_f(r, q)_b o_M^*(\mathcal{A}_r(f))_a.$$

The proof of Lemma 5.2 is similar to that of Lemma 5.1. See [Wa1] for the proof.

The following corollary shows that the boundary operator ∂ of the Morse complex satisfies $\partial \circ \partial(p) = \sum_q \sum_r \# \mathcal{M}'(f; p, r) \cdot \# \mathcal{M}'(f; r, q) q = 0$.

COROLLARY 5.3. *Let p, r, q be critical points of f such that $f(q) < f(r) < f(p)$ and $i(p) - i(r) = i(r) - i(q) = 1$. Let N_a and $a \in \bar{b}(\widehat{N}_{\hat{a}})$ be as above for $\hat{a} \in \partial_1 \overline{\mathcal{D}}_p(f)$. Let b be a point of $\mathcal{M}'(f; p, r)$ such that $\widehat{N}_{\hat{a}}$ corresponds to b . Then the following identity in $\bigwedge^\bullet T_a^*M$ holds.*

$$o_M^*(\partial \overline{\mathcal{D}}_p(f) \pitchfork \mathcal{A}_q(f))_a = -\varepsilon_f(p, r)_b \varepsilon_f(r, q)_a \iota(-\text{grad } f) o(M)_a.$$

Proof. By Lemma 5.1 and (B.5), $o_M^*(\partial \overline{\mathcal{D}}_p(f) \pitchfork \mathcal{A}_q(f))_a$ is given as follows.

$$\begin{aligned} & (-1)^{\deg o_M^*(\mathcal{A}_q(f))_a} (-1)^{i(r)} \varepsilon_f(p, r)_b o_M^*(\mathcal{D}_r(f))_a \wedge o_M^*(\mathcal{A}_q(f))_a \\ &= (-1)^{i(q)+i(r)} \varepsilon_f(p, r)_b \varepsilon_f(r, q)_a \iota(-\text{grad } f) o(M)_a \\ &= -\varepsilon_f(p, r)_b \varepsilon_f(r, q)_a \iota(-\text{grad } f) o(M)_a. \end{aligned}$$

\square

If a lies between the levels $f(r)$ and $f(p)$, then one may obtain consistent formula for $o_M^*(\mathcal{D}_p(f) \pitchfork \partial \overline{\mathcal{A}}_q(f))_a$ by using Lemma 5.2.

5.3. (Co)orientation induced on the boundary of $\overline{\mathcal{M}}_2(f)$. Let $f : M_0 \rightarrow \mathbb{R}$ be a Morse function and μ be a metric on M_0 that is Morse–Smale and that is Euclidean near critical points. For a critical point r of f , we shall describe the induced orientations of the face $\mathcal{F}_r \overline{\mathcal{M}}_2(f)$ of $\partial_1 \overline{\mathcal{M}}_2(f)$ of flow lines broken at a critical point r , that are induced from the orientation of $\overline{\mathcal{M}}_2(f)$. In the following we again follow the orientation convention of Appendix B.

Let $\bar{b} : \overline{\mathcal{M}}_2(f) \rightarrow M \times M$ be the map that assigns to each (possibly broken) flow sequence the pair of initial and terminal endpoints. If $a \in \mathcal{A}_r(f)$ and $a' \in \mathcal{D}_r(f)$, then there are open neighborhoods N_a and $N_{a'}$ of a and a' in M_0 respectively such that $\bar{b} : \bar{b}^{-1}(N_a \times N_{a'}) \rightarrow N_a \times N_{a'}$ is an embedding. Put $\widehat{N}_{(a, a')} = \bar{b}^{-1}(N_a \times N_{a'})$. Then the coorientation $o_{M \times M}^*(\partial_1 \overline{\mathcal{M}}_2(f))_{(a, a')}$ makes sense by identifying $\widehat{N}_{(a, a')}$ with $\bar{b}(\widehat{N}_{(a, a')})$.

Note that $\text{Int } \bar{b}(\widehat{N}_{(a, a')})$ is an open subset of $\mathcal{M}_2(f)$ and its closure in $N_a \times N_{a'}$ is $\bar{b}(\widehat{N}_{(a, a')})$. Hence the coorientation of $\mathcal{M}_2(f)$ induces a coorientation of the boundary $\partial \bar{b}(\widehat{N}_{(a, a')})$ at (a, a') . We define $o_{M \times M}^*(\partial_1 \overline{\mathcal{M}}_2(f))_{(a, a')}$ to be the one induced in this way.

LEMMA 5.4. *Under the assumption above, let $a \in \mathcal{A}_r(f)$ and $a' \in \mathcal{D}_r(f)$. Then*

$$o_{M \times M}^*(\partial_1 \overline{\mathcal{M}}_2(f))_{(a, a')} = (-1)^{(i(r)+1)d} o_M^*(\mathcal{A}_r(f))_a \wedge o_M^*(\mathcal{D}_r(f))_{a'}.$$

Proof. Let $i = i(r)$. By Morse lemma, it suffices to check the assertion for the standard form $h(x_1, \dots, x_d) = -\frac{x_1^2}{2} - \dots - \frac{x_i^2}{2} + \frac{x_{i+1}^2}{2} + \dots + \frac{x_d^2}{2}$ in place of f and for $r = (0, \dots, 0)$. By convention,

$$o_{\mathbb{R}^d}^*(\mathcal{D}_r(h))_x = \beta dx_{i+1} \cdots dx_d, \quad o_{\mathbb{R}^d}^*(\mathcal{A}_r(h))_x = (-1)^{i(d-i)} \beta dx_1 \cdots dx_i$$

for some $\beta = \pm 1$.

First, assume $i \geq 1$. We assume without loss of generality that $a = (0, \dots, 0, a_d)$, $a' = (a'_1, 0, \dots, 0)$ for some $a_d \geq 0$ and $a'_1 > 0$. Recall that $\overline{\mathcal{M}}_2(h)$ is the set of points $(\rho u, v) \times (u, \rho v)$ for $u \in \mathbb{R}^i$, $v \in \mathbb{R}^{d-i}$, $\rho \in [0, 1]$ (Lemma 3.6). Since the Jacobian matrix of $\varphi(\rho, u, v) = (\rho u, v) \times (u, \rho v)$ at $u = a' \in \mathbb{R}^i$, $v = a \in \mathbb{R}^{d-i}$ is (3.5), $T_{\varphi(\rho, u, v)}^* \overline{\mathcal{M}}_2(h)$ is spanned by $a'_1 dx_1 + a_d dy_d$, $\rho dx_1 + dy_1, \dots, \rho dx_i + dy_i, dx_{i+1} + \rho dy_{i+1}, \dots, dx_d + \rho dy_d$ if dx_1, \dots, dx_d (resp. dy_1, \dots, dy_d) is the standard basis of $T_a^* \mathbb{R}^d$ (resp. $T_{a'}^* \mathbb{R}^d$). In fact, if $\rho > 0$ and small,

$$o(\mathcal{M}_2(h))_{\varphi(\rho, u, v)} \sim -(a'_1 dx_1 + a_d dy_d) \wedge \bigwedge_{k=1}^i (\rho dx_k + dy_k) \wedge \bigwedge_{k=i+1}^d (dx_k + \rho dy_k). \quad (5.1)$$

Indeed, by convention in §5.1,

$$o(\mathcal{M}_2(h))_{(u, v) \times (e^t u, e^{-t} v)} = \bigwedge_{k=1}^i (dx_k + e^t dy_k) \wedge \bigwedge_{k=i+1}^d (dx_k + e^{-t} dy_k) \wedge dy_1$$

for $u \neq 0$, $v \neq 0$, $t > 0$. Then

$$o(\mathcal{M}_2(h))_{(u, v) \times (e^t u, e^{-t} v)} \wedge dy_2 \cdots dy_d = dx_1 \cdots dx_d \wedge dy_1 \cdots dy_d.$$

On the other hand,

$$\begin{aligned} & -(a'_1 dx_1 + a_d dy_d) \wedge \bigwedge_{k=1}^i (\rho dx_k + dy_k) \wedge \bigwedge_{k=i+1}^d (dx_k + \rho dy_k) \wedge dy_2 \cdots dy_d \\ &= (a'_1 - \rho a_d) \rho^{i-1} dy_1 dx_1 dx_2 \cdots dx_d dy_2 \cdots dy_d \\ &= -(a'_1 - \rho a_d) \rho^{i-1} dx_1 \cdots dx_d \wedge dy_1 \cdots dy_d. \end{aligned}$$

The coefficient $-(a'_1 - \rho a_d) \rho^{i-1}$ is negative if ρ is small.

The expression (5.1) is convenient because it extends smoothly to an orientation of $\overline{\mathcal{M}}_2(h)$ except the point from $(u, v) = (0, 0)$. At the boundary point

$$(a, a') = \varphi(0, (a'_1, 0, \dots, 0), (0, \dots, 0, a_d)) \in \partial_1 \overline{\mathcal{M}}_2(h), \quad a'_1 > 0, \quad a_d \geq 0,$$

the dual of the outward normal vector at (a, a') is given by $-(a'_1 dx_1 + a_d dy_d)$. Hence

$$\begin{aligned} o(\partial_1 \overline{\mathcal{M}}_2(h))_{(a, a')} &= dy_1 \cdots dy_i dx_{i+1} \cdots dx_d, \\ o_{\mathbb{R}^d \times \mathbb{R}^d}^*(\partial_1 \overline{\mathcal{M}}_2(h))_{(a, a')} &= (-1)^{d-i} dx_1 \cdots dx_i dy_{i+1} \cdots dy_d \\ &= (-1)^{(i+1)d} o_{\mathbb{R}^d}^*(\mathcal{A}_r(h))_a \wedge o_{\mathbb{R}^d}^*(\mathcal{D}_r(h))_{a'}. \end{aligned}$$

□

5.4. Orientations of some faces of $\partial\overline{C}_n(M)$. Now assume that $d = 3$. We shall describe the orientation of the face $\partial_{ij}\overline{C}_n(M) := \partial_{\{i,j\}}\overline{C}_n(M)$ induced from the standard orientation $o(M)_{x_1} \wedge o(M)_{x_2} \wedge \cdots \wedge o(M)_{x_n}$ of $C_n(M)$. Let

$$\Delta_{ij} = \{(x_1, x_2, \dots, x_n) \in M^n; x_i = x_j\}.$$

The interior of the face $\partial_{ij}\overline{C}_n(M)$ is naturally identified with an open subset of $\partial B\ell_{\Delta_{ij}}(M^n)$. By definition of blow-up, the boundary of $B\ell_{\Delta_{ij}}(M^n)$ is the normal sphere bundle of the submanifold Δ_{ij} . More precisely, let $N_{\Delta_{ij}}$ be the total space of the normal bundle of Δ_{ij} . By identifying a small tubular neighborhood of Δ_{ij} with that of the zero section of $N_{\Delta_{ij}}$, we may identify a small collar neighborhood of $\partial B\ell_{\Delta_{ij}}(M^n)$ with that of $\partial B\ell_0(N_{\Delta_{ij}})$.

A framing $\tau : TM \rightarrow \mathbb{R}^3 \times M$ induces a trivialization $\phi_{ij} : N_{\Delta_{ij}} \rightarrow \mathbb{R}^3 \times \Delta_{ij}$. Namely, if $\{e_1^{(i)}, e_2^{(i)}, e_3^{(i)}\}$ is the basis of $T_{x_i}M$ induced by τ , then $(T_{\vec{x}}\Delta_{ij})^\perp$ is spanned by $\{e_1^{(j)} - e_1^{(i)}, e_2^{(j)} - e_2^{(i)}, e_3^{(j)} - e_3^{(i)}\}$ and ϕ_{ij} is defined by

$$\phi_{ij}(a_1(e_1^{(j)} - e_1^{(i)}) + a_2(e_2^{(j)} - e_2^{(i)}) + a_3(e_3^{(j)} - e_3^{(i)}), \vec{x}) = (a_1, a_2, a_3) \times \vec{x}. \quad (\vec{x} \in \Delta_{ij})$$

This is smoothly extended to a trivialization $\overline{\phi}_{ij} : B\ell_0(N_{\Delta_{ij}}) \rightarrow B\ell_0(\mathbb{R}^3) \times \Delta_{ij}$. Let ω_{p-1} denote the closed $(p-1)$ -form on $B\ell_0(\mathbb{R}^p)$ that is the pullback of the SO_p -invariant volume form $\sum_{i=1}^p (-1)^{i-1} x_i dx_1 \wedge \cdots \wedge \widehat{dx}_i \wedge \cdots \wedge dx_p$ (dx_i is deleted) on S^{p-1} by the natural map $B\ell_0(\mathbb{R}^p) \rightarrow S^{p-1}$ (see Appendix D). If $i < j$, let

$$o(\Delta_{ij})_{\vec{x}} = (-1)^j o(M)_{x_1} \wedge \cdots \wedge o(\Delta_M)_{(x_i, x_j)} \wedge \cdots \wedge \widehat{o(M)}_{x_j} \wedge \cdots \wedge o(M)_{x_n}.$$

Now we orient $\partial B\ell_{\Delta_{ij}}(M^n) = \partial B\ell_0(N_{\Delta_{ij}})$ as follows.

$$o(\partial B\ell_0(N_{\Delta_{ij}})) = \overline{\phi}_{ij}^*(\omega_2 \wedge o(\Delta_{ij})).$$

This is the one induced from the standard orientation $o(M)_{x_1} \wedge o(M)_{x_2} \wedge \cdots \wedge o(M)_{x_n}$ of $C_n(M)$. See [Wa1] for detail.

5.5. Standard co-orientation of \mathcal{M}_Γ from graph orientation. We shall first give another definition of $\mathcal{M}_\Gamma(\vec{f})$ using $\mathcal{M}_2(f)$ and $\mathcal{N}_{pq}(f)$. For a graph Γ without bivalent vertices, the space $\mathcal{M}_\Gamma(\vec{f})$ can be defined as the intersection of submanifolds of $C_n(M)$, as follows. Suppose for simplicity that the separated edges of Γ are labeled $1, 2, \dots, a$. Let $\pi_{ij} : C_n(M) \rightarrow C_2(M)$ be the projection $(x_1, \dots, x_n) \mapsto (x_i, x_j)$ and let Θ_ℓ and H_ℓ be the submanifolds of $C_n(M)$ defined by

$$\Theta_\ell = \pi_{ij}^{-1}(\mathcal{M}_2(f_\ell)), \quad H_\ell = \pi_{ij}^{-1}(\mathcal{N}_{p_\ell q_\ell}(f_\ell)),$$

where $i = \sigma(\ell), j = \tau(\ell)$. Their codimensions are $\text{codim } \Theta_\ell = 2$, $\text{codim } H_\ell = 3 - i(p_\ell) + i(q_\ell) = 3 - \eta_\ell$. Then we have

$$\mathcal{M}_\Gamma(\vec{f}) = \bigcap_{j=1}^a H_j \cap \bigcap_{j=a+1}^m \Theta_j,$$

where we assume that the intersection is transversal.

Let $o_{C_n(M)}^*(\Theta_\ell) \in \Omega_{\text{dR}}^2(B)$ and $o_{C_n(M)}^*(H_\ell) \in \Omega_{\text{dR}}^{3-\eta_\ell}(B)$ be differential forms on a neighborhood B of a point on the crossing $\mathcal{M}_\Gamma(\vec{f})$ in $C_n(M)$, defined by

$$o_{C_n(M)}^*(\Theta_\ell) = \pi_{ij}^* o_{C_2(M)}^*(\mathcal{M}_2(f_\ell)), \quad o_{C_n(M)}^*(H_\ell) = \pi_{ij}^* o_{C_2(M)}^*(\mathcal{N}_{p_\ell q_\ell}(f_\ell)).$$

We represent co-orientation of $\mathcal{M}_\Gamma(\vec{f})$ by a wedge product of $o_{C_n(M)}^*(H_j)$'s and $o_{C_n(M)}^*(\Theta_j)$'s. Let $\mathcal{G}_{n,m,\Sigma(1,1,\dots,1)}^0(\vec{C}) = \mathcal{G}_{n,m,(2,1,\dots,1)}^0(\vec{C}) \cup \mathcal{G}_{n,m,(1,2,1,\dots,1)}^0(\vec{C}) \cup \dots \cup \mathcal{G}_{n,m,(1,1,\dots,2)}^0(\vec{C})$ and $\mathcal{G}_{n,m,\Sigma^{-1}(1,1,\dots,1)}^0(\vec{C}) = \mathcal{G}_{n,m,(0,1,\dots,1)}^0(\vec{C}) \cup \mathcal{G}_{n,m,(1,0,1,\dots,1)}^0(\vec{C}) \cup \dots \cup \mathcal{G}_{n,m,(1,1,\dots,0)}^0(\vec{C})$. We now define the coorientations for the graphs that are relevant.

5.5.1. Graphs in $\mathcal{G}_{2k,3k}^0(\vec{C})$, $\mathcal{G}_{2k,3k,\Sigma(1,1,\dots,1)}^0(\vec{C})$, $\mathcal{G}_{2k,3k,\Sigma^{-1}(1,1,\dots,1)}^0(\vec{C})$. Now we assume that $\Gamma \in \mathcal{G}_{2k,3k}^0(\vec{C})$, so that $\text{codim } \Theta_j = \text{codim } H_j = 2$. We shall define a standard co-orientation of $\mathcal{M}_\Gamma(\vec{f})$ in a product of M from the labels and the edge orientations of Γ , as follows. The labels of trivalent vertices determine the correspondence between $V(\Gamma)$ and the coordinate $(x_1, x_2, \dots, x_{2k})$. The edge orientation determine which of π_{ij} and π_{ji} is used to define Θ_ℓ or H_ℓ . Then we define the standard co-orientation of $\mathcal{M}_\Gamma(\vec{f})$ by the formula

$$o_{C_{2k}(M)}^*(\mathcal{M}_\Gamma(\vec{f})) = \bigwedge_{j=1}^a o_{C_{2k}(M)}^*(H_j) \wedge \bigwedge_{j=a+1}^{3k} o_{C_{2k}(M)}^*(\Theta_j) \in \Omega_{\text{dR}}^{6k}(B).$$

Since $\text{codim } \Theta_j$ and $\text{codim } H_j$ are even, the order of wedge product does not matter. This depends only on the orientation $o(\Gamma)$ of Γ . This gives $\#\mathcal{M}_\Gamma(\vec{f})$ in §2.5.

The same rule equally works for graphs in $\mathcal{G}_{2k,3k,\Sigma(1,1,\dots,1)}^0(\vec{C})$, $\mathcal{G}_{2k,3k,\Sigma^{-1}(1,1,\dots,1)}^0(\vec{C})$ etc. without bivalent vertices, since in that case only one H_j is odd codimensional, so again the coorientation of $\mathcal{M}_\Gamma(\vec{f})$ is canonically determined from the graph orientation by the same formula.

5.5.2. Graphs in $\mathcal{G}_{2k,3k,\vec{\eta}}^0(\vec{C})$, $\eta_{j_2} = 2$, $\eta_{j_0} = 0$. For a graph in $\mathcal{G}_{2k,3k,\vec{\eta}}^0(\vec{C})$ without bivalent vertices such that there is exactly one j with $\eta_j = 2$, exactly one j with $\eta_j = 0$ and otherwise $\eta_j = 1$, let j_2 and j_0 be such that $\eta_{j_2} = 2$, $\eta_{j_0} = 0$. The codimensions of H_{j_0} and H_{j_2} are odd. Then we define a standard co-orientation $o_{C_{2k}(M)}^*(\mathcal{M}_\Gamma(\vec{f}))$ of $\mathcal{M}_\Gamma(\vec{f})$ by

$$o_{C_{2k}(M)}^*(H_{j_0}) \wedge o_{C_{2k}(M)}^*(H_{j_2}) \wedge \bigwedge_{\substack{1 \leq j \leq a \\ j \neq j_0, j_2}} o_{C_{2k}(M)}^*(H_j) \wedge \bigwedge_{j=a+1}^{3k} o_{C_{2k}(M)}^*(\Theta_j).$$

5.5.3. Graphs in $\mathcal{G}_{2k,3k,\Sigma(1,1,\dots,1)}^0(\vec{C})$ with one bivalent vertex. We also consider co-orientations of (not yet defined) $\mathcal{M}_\Gamma(\vec{f})$ for graphs $\Gamma \in \mathcal{G}_{2k,3k,\Sigma(1,1,\dots,1)}^0(\vec{C})$ with only one bivalent vertex. For three possibilities for the position of the bivalent vertex in Γ , we define $\mathcal{M}_\Gamma(\vec{f})$ and its standard co-orientation as follows.

(1) $\Gamma = \begin{array}{c} p_i \circ \\ \swarrow \quad \searrow \\ r_i \circ \quad \circ \\ \downarrow \quad \uparrow \\ q_i \circ \end{array} \square$, $i(p_i) = i(r_i) + 1 = i(q_i) + 2$. Let Γ' be the graph obtained

from Γ by removing the segment $\partial^{(i)}(p_i, r_i)$. In this case, we define

$$\mathcal{M}_\Gamma(\vec{f}) = \mathcal{M}'(f_i; p_i, r_i) \times \mathcal{M}_{\Gamma'}(\vec{f}).$$

If a point $b \in \mathcal{M}'(f_i; p_i, r_i)$ is specified, we may consider a coorientation of $\{b\} \times \mathcal{M}_{\Gamma'}(\vec{f})$ in $C_{2k}(M)$ by identifying it with $\mathcal{M}_{\Gamma'}(\vec{f})$. Under these assumptions, we define

$$o_{C_{2k}(M)}^*(\mathcal{M}_\Gamma(\vec{f}))_{b \times (x_1, \dots, x_{2k})} = \varepsilon_f(p_i, r_i)_b o_{C_{2k}(M)}^*(\mathcal{M}_{\Gamma'}(\vec{f}))_{(x_1, \dots, x_{2k})}.$$

(2) $\Gamma = \begin{array}{c} p_i \circ \\ \swarrow \quad \searrow \\ \square \\ \swarrow \quad \searrow \\ s_i \circ \\ \swarrow \quad \searrow \\ q_i \circ \end{array}$, $i(q_i) = i(s_i) - 1 = i(p_i) - 2$. Let Γ' be the graph obtained

from Γ by removing the segment $\partial^{(i)}(s_i, q_i)$. In this case, we define

$$\mathcal{M}_\Gamma(\vec{f}) = \mathcal{M}'(f_i; s_i, q_i) \times \mathcal{M}_{\Gamma'}(\vec{f}).$$

If a point $b \in \mathcal{M}'(f_i; s_i, q_i)$ is specified, we may consider a coorientation of $\{b\} \times \mathcal{M}_{\Gamma'}(\vec{f})$ in $C_{2k}(M)$ by identifying it with $\mathcal{M}_{\Gamma'}(\vec{f})$. Under these assumptions, we define

$$o_{C_{2k}(M)}^*(\mathcal{M}_\Gamma(\vec{f}))_{b \times (x_1, \dots, x_{2k})} = \varepsilon_f(s_i, q_i)_b o_{C_{2k}(M)}^*(\mathcal{M}_{\Gamma'}(\vec{f}))_{(x_1, \dots, x_{2k})}.$$

(3) $\Gamma = \begin{array}{c} \diagup \quad \diagdown \\ \circ \\ \diagdown \quad \diagup \\ \circ \\ r_\ell \end{array}$. In this case, $o_{C_{2k}(M)}^*(\mathcal{M}_\Gamma(\vec{f}))$ is determined by the intersection of

$H'_\ell = \pi_{i_j}^{-1}(\mathcal{A}_{r_\ell}(f_\ell) \times \mathcal{D}_{r_\ell}(f_\ell))$ (codimension $i(r_\ell) + (3 - i(r_\ell)) = 3$) with the intersection of Θ_j 's and H_j 's of codimension 2. We define $o_{C_{2k}(M)}^*(\mathcal{M}_\Gamma(\vec{f}))$ by

$$o_{C_{2k}(M)}^*(H_{j_2}) \wedge \bigwedge_{\substack{1 \leq j \leq a \\ j \neq j_2}} o_{C_{2k}(M)}^*(H_j) \wedge o_{C_{2k}(M)}^*(H'_\ell) \wedge \bigwedge_{\substack{a+1 \leq j \leq 3k \\ j \neq \ell}} o_{C_{2k}(M)}^*(\Theta_j).$$

5.6. Induced coorientation on $\overline{\partial} \mathcal{M}_\Gamma$. Now we define boundary operators, which formally describe the boundary of moduli space of flow graphs. We define a linear map $d : \mathcal{G}_{n,m,\vec{\eta}}(\vec{C}) \rightarrow \bigoplus_{j=1}^\ell \mathcal{G}_{n-1,m-1,(\eta_1, \dots, \widehat{\eta}_j, \dots, \eta_\ell)}(C_*^{(1)}, \dots, \widehat{C}_*^{(j)}, \dots, C_*^{(\ell)})$ by

$$d(\Gamma, o) = \sum_{e \in \text{Comp}(\Gamma)} (\Gamma/e, \text{induced ori}),$$

where for $e_j = (u, v)$ (u, v : vertices) the induced orientation of Γ/e_j is formally given by $-\iota(v^*)(v_1 \wedge \dots \wedge v_n) \wedge (e_1^+ \wedge e_1^-) \wedge \dots \wedge (e_m^+ \wedge e_m^-)$, where v^* is the dual of v with respect to the standard inner product of $\mathbb{R}^{B(\Gamma)}$ and ι is the interior product. Also, let $d'\Gamma = \sum_{e \in \text{Comp}(\Gamma) \cup \text{Se}(\Gamma)} d'_e \Gamma$, where

$$d'_e \begin{array}{c} \diagup \quad \diagdown \\ \circ \\ \diagdown \quad \diagup \\ \circ \\ e \end{array} = \sum_{r_i \in P_*^{(i)}} (-1)^{i(r_i)} \begin{array}{c} \diagup \quad \diagdown \\ \circ \\ \diagdown \quad \diagup \\ \circ \\ r_i \end{array} \quad (\beta(i) = e),$$

$$d'_e \begin{array}{c} p_i \circ \\ \swarrow \quad \searrow \\ \square \\ \swarrow \quad \searrow \\ q_i \circ \end{array} = \sum_{\substack{r_i \in P_*^{(i)} \\ i(r_i) = i(p_i) - 1}} (-1)^{i(q_i)} \begin{array}{c} p_i \circ \\ \swarrow \quad \searrow \\ \square \\ \swarrow \quad \searrow \\ q_i \circ \end{array} + \sum_{\substack{s_i \in P_*^{(i)} \\ i(s_i) = i(q_i) + 1}} (-1)^{i(s_i)} \begin{array}{c} p_i \circ \\ \swarrow \quad \searrow \\ \square \\ \swarrow \quad \searrow \\ s_i \circ \\ \swarrow \quad \searrow \\ q_i \circ \end{array},$$

($\beta(i) = e$), where the orientation of $d'_e \Gamma$ is the naturally induced one.

Let $\bar{b}_\Gamma : \overline{\mathcal{M}}_\Gamma(\vec{f}) \rightarrow \overline{C}_{2k}(M)$ be the map which gives the positions of the $2k$ trivalent vertices in a flow-graph (Remark 4.2). We call a face of $\overline{\mathcal{M}}_\Gamma(\vec{f})$ corresponding to a degeneration of one of the terms in $(d + d')\Gamma$ a *principal face*. We call a face of $\overline{\mathcal{M}}_\Gamma(\vec{f})$ that is not principal a *hidden face*. When Γ consists only of compact edges, we define the *anomalous face* of $\overline{\mathcal{M}}_\Gamma(\vec{f})$ as the hidden face corresponding to the collapse of all the $2k$ points. Let $\overline{\mathcal{M}}_\Gamma^{\text{hi}}(\vec{f})$ denote the union of all the hidden faces of $\overline{\mathcal{M}}_\Gamma(\vec{f})$.

PROPOSITION 5.5. *Suppose $d = 3$ and $(\vec{f}, \vec{\mu})$ is generic as in Proposition 2.5. For $\Gamma \in \mathcal{G}_{2k, 3k, \Sigma(1, \dots, 1)}^0(\vec{C})$ without bivalent vertices, there is a natural diffeomorphism*

$$\partial \overline{\mathcal{M}}_\Gamma(\vec{f}) \cong \overline{\mathcal{M}}_{(d+d')\Gamma}(\vec{f}) \amalg \overline{\mathcal{M}}_\Gamma^{\text{hi}}(\vec{f})$$

of oriented 0-manifolds (for some orientation of $\overline{\mathcal{M}}_\Gamma^{\text{hi}}(\vec{f})$), where $\overline{\mathcal{M}}_{\Gamma_1 + \dots + \Gamma_r} = \overline{\mathcal{M}}_{\Gamma_1} + \dots + \overline{\mathcal{M}}_{\Gamma_r}$.

Proof. We shall compare the co-orientation of a face of $\partial \overline{\mathcal{M}}_\Gamma(\vec{f})$ induced from $o_{C_{2k}(M)}^*(\mathcal{M}_\Gamma(\vec{f}))$ and the standard one of the same face of $\partial \overline{\mathcal{M}}_\Gamma(\vec{f})$ fixed in §5.5.

Suppose that $\Gamma \in \mathcal{G}_{2k, 3k, \vec{\eta}}^0(\vec{C})$ has no bivalent vertex and that there is only one number j_2 with $\eta_{j_2} = 2$ and $\eta_\ell = 1$ for $\ell \neq j_2$. As in §5.5, we consider $\mathcal{M}_\Gamma(\vec{f})$ as the intersection of the chains H_j 's and Θ_j 's in $C_{2k}(M)$.

For a number ℓ such that $1 \leq \ell \leq 3k$, let

$$\Sigma_\ell = \begin{cases} \bigcap_{\substack{1 \leq j \leq a \\ j \neq \ell}} H_j \cap \bigcap_{j=a+1}^{3k} \Theta_j & \text{if } 1 \leq \ell \leq a \\ \bigcap_{j=1}^a H_j \cap \bigcap_{\substack{a+1 \leq j \leq 3k \\ j \neq \ell}} \Theta_j & \text{if } a+1 \leq \ell \leq 3k \end{cases}$$

Then by Proposition 2.4, $\text{codim } \Sigma_\ell = \text{codim } \mathcal{M}_\Gamma(\vec{f}) - \text{codim } H_\ell = (2kd - (2k - 3k)d - 3k - 1) - (d + \eta_\ell) = 6k - 4 - \eta_\ell \equiv \eta_\ell \pmod{2}$.

First, we consider the faces corresponding to the collapse of a compact edge. We check that the contribution of such faces is $\overline{\mathcal{M}}_{d\Gamma}(\vec{f})$. We consider the principal face corresponding to the collapse of the ℓ -th edge of Γ . By convention,

$$o(\overline{\mathcal{M}}_2(f_\ell))_{(x,y)} = o(\Delta_M)_{(x,x)} \wedge (-df_\ell)_y + O(d(x,y)),$$

where $d(x,y)$ is the geodesic distance. Let $\xi = -\text{grad } f_\ell$. The orientation induced on the face Δ_M of $\partial \overline{\mathcal{M}}_2(f_\ell)$ is

$$\iota(\xi_x \oplus (-\xi_y)) o(\Delta_M)_{(x,x)} \wedge (-df_\ell)_y = -o(\Delta_M)_{(x,x)} \quad (\text{if } x = y).$$

This implies that the coorientation of the boundary of $\overline{\mathcal{M}}_2(f_\ell)$ on $\partial B\ell_{\Delta_M}(M^2)$ is given by ω_2 , showing that the contribution of a collapse of a compact edge is $\overline{\mathcal{M}}_{d\Gamma}(\vec{f})$.

Let X be one of the graphs that appear in the sum $d'_{\beta(k)}\Gamma$. We shall describe the co-orientation of the face \mathcal{S}_X of $\partial \overline{\mathcal{M}}_\Gamma(\vec{f})$ corresponding to X induced from the standard co-orientation of $\mathcal{M}_\Gamma(\vec{f})$ in $C_{2k}(M)$.

(1) $X = \begin{array}{c} p_\ell \circ \\ r_\ell \circ \quad \diagdown \quad \diagup \\ \quad \quad \quad \square \\ q_\ell \circ \quad \diagup \quad \diagdown \\ \sigma \end{array}$, where $p_\ell, q_\ell, r_\ell \in \Sigma(f_\ell)$. By Lemma 5.1, (B.3) and (B.5),

the co-orientation of \mathcal{S}_X induced from the standard one

$$o_{C_{2k}(M)}^*(\mathcal{M}_\Gamma(\vec{f})) = o_M^*(\mathcal{A}_{q_\ell}(f_\ell)) \wedge o_M^*(\mathcal{D}_{p_\ell}(f_\ell)) \wedge o_{C_{2k}(M)}^*(\Sigma_\ell) \quad (5.2)$$

is given by

$$\begin{aligned} & (-1)^{d-1} (-1)^{2kd-1} (-1)^{i(r_\ell)} (-1)^{\eta_\ell} \varepsilon_f(p_\ell, r_\ell)_b o_M^*(\mathcal{A}_{q_\ell}(f_\ell)) o_M^*(\mathcal{D}_{r_\ell}(f_\ell)) o_{C_{2k}(M)}^*(\Sigma_\ell) \\ & = (-1)^{i(q_\ell)} \varepsilon_f(p_\ell, r_\ell)_b o_{C_{2k}(M)}^*(\mathcal{M}_{\Gamma'}(\vec{f})) = (-1)^{i(q_\ell)} o_{C_{2k}(M)}^*(\mathcal{M}_X(\vec{f})). \end{aligned}$$

(2) $X = \begin{array}{c} p_\ell \\ \swarrow \\ s_\ell \\ \swarrow \\ q_\ell \end{array} \circlearrowleft \square$, where $p_\ell, q_\ell, s_\ell \in \Sigma(f_\ell)$. By Lemma 5.2, (B.3) and (B.5),

the co-orientation of \mathcal{S}_X induced from the standard one (5.2) is given by

$$\begin{aligned} & -(-1)^{d-1}(-1)^{2kd-1}(-1)^{3-i(p_\ell)}(-1)^{\eta_\ell} \varepsilon_f(s_\ell, q_\ell)_b o_M^*(\mathcal{A}_{s_\ell}(f_\ell)) o_M^*(\mathcal{D}_{p_\ell}(f_\ell)) o_{C_{2k}(M)}^*(\Sigma_\ell) \\ & = (-1)^{i(s_\ell)} \varepsilon_f(s_\ell, q_\ell)_b o_{C_{2k}(M)}^*(\mathcal{M}_{\Gamma'}(\vec{f})) = (-1)^{i(s_\ell)} o_{C_{2k}(M)}^*(\mathcal{M}_X(\vec{f})). \end{aligned}$$

(3) $X = \begin{array}{c} \diagup \\ \diagdown \\ \circlearrowleft \\ \diagup \\ \diagdown \end{array} r_\ell$, where $r_\ell \in \Sigma(f_\ell)$. The induced co-orientation on the boundary is

as in Lemma 5.4, which differs from the standard coorientation by $(-1)^{i(r_\ell)+1+\eta_\ell} = (-1)^{i(r_\ell)}$.

Now we have seen that the signs in the formula of the definition of d' are consistent with the induced co-orientations on the boundary of $\overline{\mathcal{M}}_\Gamma(\vec{f})$. \square

6. Independence of combinatorial propagator. In the definition of $Z_{2k,3k}(\vec{f})$, a sequence $\vec{g} = (g_1, \dots, g_{3k})$ of combinatorial propagators for \vec{C} is chosen. Recall that $Z_{2k,3k}(\vec{f}) = \text{Tr}_{\vec{g}}(\tilde{\gamma}_{2k,3k})$ for $\tilde{\gamma}_{2k,3k} = \sum_{\Gamma \in \mathcal{G}_{2k,3k}^0(\vec{C})} \# \mathcal{M}_\Gamma(\vec{f}) \Gamma \in \mathcal{G}_{2k,3k}(\vec{C})$. In this section, we shall prove the following lemma.

LEMMA 6.1. $Z_{2k,3k}(\vec{f}) = \text{Tr}_{\vec{g}}(\tilde{\gamma}_{2k,3k})$ does not depend on the choice of \vec{g} .

6.1. Boundary strata of $\overline{\mathcal{M}}_\Gamma$.

PROPOSITION 6.2. Suppose $d = 3$. Let Γ be a graph in $\mathcal{G}_{2k,3k,\Sigma(1,\dots,1)}^0(\vec{C})$ without bivalent vertices. For a permutation $\sigma \in \mathfrak{S}_{3k}$ and for a subset $\tau \subset E(\Gamma)$, let Γ_σ^τ denote the labeled graph obtained from Γ by permuting the labels of edges by σ and reversing the orientations of all the edges in τ . For \vec{f} generic, we have

$$\sum_{\sigma \in \mathfrak{S}_{3k}} \sum_{\tau \subset E(\Gamma)} (-1)^{|\tau|} \# \overline{\mathcal{M}}_{(d+d')\Gamma_\sigma^\tau}(\vec{f}) = \sum_{\sigma \in \mathfrak{S}_{3k}} \sum_{\tau \subset E(\Gamma)} (-1)^{|\tau|} \# \partial \overline{\mathcal{M}}_{\Gamma_\sigma^\tau}(\vec{f}) = 0. \quad (6.1)$$

The sum in the LHS of (6.1) can be considered as a part of the sum $\sum_{\Gamma} \# \overline{\mathcal{M}}_{(d+d')\Gamma}(\vec{f}) \Gamma$ because the sign $(-1)^{|\tau|}$ will be canceled out with the change of the graph orientation: $\Gamma_\sigma^\tau = (-1)^{|\tau|} \Gamma$. For the proof of Proposition 6.2, we need two lemmas, which are analogues of Kontsevich's lemma [Ko, Lemma 2.2]. In the following H is a subgraph of $\Gamma \in \mathcal{G}_{2k,3k,\Sigma(1,\dots,1)}^0(\vec{C})$ with only compact edges.

LEMMA 6.3. Suppose that H has a bivalent black vertex a and that the edges of H including the vertex a are (b, a) and (a, c) where b and c are both black vertices (it may happen that $b = c$). Let H' be the labeled graph obtained from H by exchanging labels for edges (b, a) and (a, c) . Let $\alpha(H)$ and $\alpha(H')$ be the chains of M given by the projections $\overline{\mathcal{M}}_H^{\text{local}}(\vec{\gamma}) \rightarrow M$ and $\overline{\mathcal{M}}_{H'}^{\text{local}}(\vec{\gamma}) \rightarrow M$, respectively. Then we have

$$\alpha(H) + \alpha(H') = 0.$$

Proof. Let $n = |V(H)|$ and let $(x_1, \dots, x_n) \in \overline{C}_n^{\text{local}}(\mathbb{R}^3)$ be a point on $\overline{\mathcal{M}}_H^{\text{local}}(\vec{\gamma})$. Suppose that the vertices a, b and c of H correspond to x_α, x_β and x_γ respectively. Then consider the automorphism $s : \overline{C}_n^{\text{local}}(\mathbb{R}^3) \rightarrow \overline{C}_n^{\text{local}}(\mathbb{R}^3)$ which sends x_α to $x_\beta + x_\gamma - x_\alpha$ and fixes other points. Then s exchanges $\overline{\mathcal{M}}_H^{\text{local}}(\vec{\gamma})$ and $\overline{\mathcal{M}}_{H'}^{\text{local}}(\vec{\gamma})$.

Put $y_\alpha = x_\beta + x_\gamma - x_\alpha$ and $\theta(\ell)_{(x,y)} = o_{\mathbb{R}^3 \times \mathbb{R}^3}^*(\Theta_\ell(\gamma\ell))_{(x,y)}$ (see Definition 2.7). Let $V_\alpha \in \wedge^3 T_{x_\alpha} \mathbb{R}^3$ and $V'_\alpha \in \wedge^3 T_{y_\alpha} \mathbb{R}^3$ be nontrivial elements that give the orientation of \mathbb{R}^3 . Then the evaluation with V_α (resp. with V'_α) gives a map $\wedge^k(T_{x_\alpha} \mathbb{R}^3 + T_{x_\beta} \mathbb{R}^3 + T_{x_\gamma} \mathbb{R}^3) \rightarrow \wedge^{k-3}(T_{x_\beta} \mathbb{R}^3 + T_{x_\gamma} \mathbb{R}^3)$ (resp. $\wedge^k(T_{y_\alpha} \mathbb{R}^3 + T_{x_\beta} \mathbb{R}^3 + T_{x_\gamma} \mathbb{R}^3) \rightarrow \wedge^{k-3}(T_{x_\beta} \mathbb{R}^3 + T_{x_\gamma} \mathbb{R}^3)$) and we have

$$\begin{aligned} \langle \theta(\ell)_{(x_\beta, x_\alpha)} \wedge \theta(\ell')_{(x_\alpha, x_\gamma)}, V_\alpha \rangle &= \langle s^*(\theta(\ell)_{(y_\alpha, x_\gamma)} \wedge \theta(\ell')_{(x_\beta, y_\alpha)}), V_\alpha \rangle \\ &= \langle \theta(\ell)_{(y_\alpha, x_\gamma)} \wedge \theta(\ell')_{(x_\beta, y_\alpha)}, ds_* V_\alpha \rangle = -\langle \theta(\ell')_{(x_\beta, y_\alpha)} \wedge \theta(\ell)_{(y_\alpha, x_\gamma)}, V'_\alpha \rangle. \end{aligned}$$

This implies that the projections $(x_\alpha, x_\beta, x_\gamma) \mapsto (x_\beta, x_\gamma)$ and $(y_\alpha, x_\beta, x_\gamma) \mapsto (x_\beta, x_\gamma)$, whose fiber in $\overline{\mathcal{M}}_H^{\text{local}}(\vec{\gamma})$ and $\overline{\mathcal{M}}_{H'}^{\text{local}}(\vec{\gamma})$ is at most 0-dimensional, induce opposite chains. \square

The following lemma can be proved in the same way as Lemma 6.3.

LEMMA 6.4. *Suppose that H has a bivalent black vertex a and that the edges of H including the vertex a are (a, b) and (a, c) where b and c are both black vertices (it may happen that $b = c$). Let H' be the labeled graph obtained from H by exchanging labels for edges (a, b) and (a, c) and reversing the orientations of both edges. Let $\alpha(H)$ and $\alpha(H')$ be the chains of M given by the projections $\overline{\mathcal{M}}_H^{\text{local}}(\vec{\gamma}) \rightarrow M$ and $\overline{\mathcal{M}}_{H'}^{\text{local}}(\vec{\gamma}) \rightarrow M$, respectively. Then we have*

$$\alpha(H) + \alpha(H') = 0.$$

LEMMA 6.5. *Suppose that H has a univalent black vertex a and $|V(H)| \geq 3$. Then $\overline{\mathcal{M}}_H^{\text{local}}(\vec{\gamma})$ admits a smooth free \mathbb{R} -action.*

Proof. Suppose that the edge of H including the vertex a is (a, b) where b is a black vertex. There is a dilation of the linear trajectory corresponding to (a, b) in $\overline{\mathcal{M}}_H^{\text{local}}(\vec{\gamma})$, which fixes points in $V(H) - \{a\}$. Since $|V(H)| \geq 3$, this \mathbb{R} -action is free in $\overline{\mathcal{C}}_n^{\text{local}}(\mathbb{R}^3)$ and gives a desired \mathbb{R} -action. \square

Proof of Proposition 6.2. The assumption $\Gamma \in \mathcal{G}_{2k, 3k, \Sigma(1, \dots, 1)}^0(\vec{C})$ implies that $\overline{\mathcal{M}}_\Gamma(\vec{f})$ is 1-dimensional by Proposition 2.4. Obviously, $\#\partial\overline{\mathcal{M}}_{\Gamma_\sigma}(\vec{f}) = 0$. Hence by Proposition 5.5, it suffices to prove that the contributions of the hidden faces cancel each other out in the sum. For a subset A of $V(\Gamma)$, let Γ_A denote the subgraph of Γ such that $V(\Gamma_A) = A$ and $E(\Gamma_A)$ consists of all edges of $E(\Gamma)$ between points in A . Suppose Γ and A are such that $E(\Gamma_A) = \text{Comp}(\Gamma_A)$. Let $\vec{f}_A \subset \vec{f}$ be the subsequence corresponding to the subset $E(\Gamma_A) \subset E(\Gamma)$ and let $-\text{grad} \vec{f}_A = (-\text{grad} f_{i_1}, \dots, -\text{grad} f_{i_{|A|}})$, where $i_1, \dots, i_{|A|}$ are the labels of the edges in Γ_A . According to the description of $\partial\overline{\mathcal{C}}_n(M)$ in §4.2, the face of $\partial\overline{\mathcal{M}}_\Gamma(\vec{f})$ coming from the face $\partial_A\overline{\mathcal{C}}_n(M)$ is diffeomorphic to the pullback of the diagram

$$\overline{\mathcal{M}}_{\Gamma/\Gamma_A}(\vec{f} \setminus \vec{f}_A) \rightarrow M \leftarrow \overline{\mathcal{M}}_{\Gamma_A}^{\text{local}}(-\text{grad} \vec{f}_A),$$

which is at most an oriented 0-manifold. Here, we consider $\overline{\mathcal{M}}_{\Gamma_A}^{\text{local}}(-\text{grad} \vec{f}_A)$ as a subspace of the $\overline{\mathcal{C}}_{|A|}^{\text{local}}(\mathbb{R}^3)$ -bundle over $B\ell(M, \bigcup_{i \in A} \Sigma(f_i))$. If $|A| \geq 3$, then since Γ is a graph in $\mathcal{G}_{2k, 3k, \Sigma(1, \dots, 1)}^0(\vec{C})$, the subgraph Γ_A must have bivalent or univalent black

vertices or none of them. If $|A| = 2$ and Γ_A is a ‘double-edge’, namely, consists of two black vertices and two compact edges connecting them, then Γ_A has a bivalent black vertex.

If Γ_A has a bivalent black vertex, then we have $\alpha(\Gamma_A) + \alpha(\Gamma'_A) = 0$ by Lemma 6.3 or 6.4. Hence by taking the sum over σ and τ , the contributions of Γ_A with bivalent vertex cancel with each other. If Γ_A has a univalent black vertex, then the dimension of the image of the projection $\overline{\mathcal{M}}_{\Gamma_A}^{\text{local}}(-\text{grad } \vec{f}_A) \rightarrow M$ decreases by 1 by Lemma 6.5 and the total dimension of the corresponding face is -1 , in which case the face is generically empty.

If $E(\Gamma_A) = \emptyset$, then Γ/Γ_A has a vertex of valence ≥ 6 . In this case, one can see by Proposition 2.4 that $\overline{\mathcal{M}}_{\Gamma/\Gamma_A}(\vec{f} \setminus \vec{f}_A) = \overline{\mathcal{M}}_{\Gamma/\Gamma_A}(\vec{f}) = \emptyset$ if \vec{f} is generic.

Finally, we must check that there are no contribution of $\partial_{A \cup \{\infty\}} \overline{\mathcal{C}}_{2k}(M)$ for generic \vec{f} . This has been checked in [Sh]. We outline the proof with our notations. We may identify the interior of $\partial_{A \cup \{\infty\}} \overline{\mathcal{C}}_{2k}(M)$ with $C_{2k-j}^\infty(M) \times C_j^\infty(\mathbb{R}^3)$, where

$$C_j^\infty(\mathbb{R}^3) = \left\{ (y_1, \dots, y_j) \in C_j(\mathbb{R}^3); \sum_{\ell=1}^j \|y_\ell\|^2 = 1 \right\}.$$

Let $f_j^\infty : \mathbb{R}^3 \rightarrow \mathbb{R}$ ($j = 1, 2, \dots, 3k$) be the linear map such that $\varphi_\infty^* f_j^\infty$ agrees with f_j near ∞_M . Let $\vec{f}^\infty = (f_1^\infty, \dots, f_{3k}^\infty)$ and let $B = V(\Gamma) \setminus A$. Suppose that $E(\Gamma/\Gamma_B) = \text{Comp}(\Gamma/\Gamma_B)$. Let $\mathcal{M}_{\Gamma/\Gamma_B}^\infty(\vec{f}^\infty \setminus \vec{f}_B^\infty)$ be the space of affine graphs $(\Gamma, \Gamma_B) \rightarrow (\mathbb{R}^3, \{0\})$ modulo the dilation of \mathbb{R}^3 whose edge not in $E(\Gamma_B)$ labeled ℓ follows the negative gradient of f_ℓ^∞ . Then (the interior of) the face of $\partial \overline{\mathcal{M}}_\Gamma(\vec{f})$ coming from $\partial_{A \cup \{\infty\}} \overline{\mathcal{C}}_{2k}(M)$ is diffeomorphic to $\mathcal{M}_{\Gamma_B}(\vec{f}_B) \times \mathcal{M}_{\Gamma/\Gamma_B}^\infty(\vec{f}^\infty \setminus \vec{f}_B^\infty)$. The configuration space $C_j^\infty(\mathbb{R}^3)$ is $(3j - 1)$ -dimensional. If the number of edges in $E(\Gamma)$ that intersect both $V(\Gamma_A)$ and $V(\Gamma_B)$ is m , then the codimension of $\mathcal{M}_{\Gamma/\Gamma_B}^\infty(\vec{f}^\infty \setminus \vec{f}_B^\infty)$ is $2 \times \frac{3j+m}{2} = 3j + m$. Since m is non-negative, the codimension exceeds $\dim C_j^\infty(\mathbb{R}^3) = 3j - 1$ and the moduli space $\mathcal{M}_{\Gamma/\Gamma_B}^\infty(\vec{f}^\infty \setminus \vec{f}_B^\infty)$ must be empty. Hence there are no face of $\partial \overline{\mathcal{M}}_\Gamma(\vec{f})$ in $\partial_{A \cup \{\infty\}} \overline{\mathcal{C}}_{2k}(M)$.

These together with Proposition 5.5 imply the proposition. \square

6.2. Independence of combinatorial propagator. Let $\partial^{(i)}(x, y)$ denote the graph $\begin{matrix} x^\circ \\ \curvearrowright \\ y^\circ \end{matrix}$ where $x, y \in P_*^{(i)}$. Let Γ be a \vec{C} -colored graph having a separated edge

$\beta(i) \in \text{Se}(\Gamma)$ such that basis elements x and $y \in P_*^{(i)}$ attached on the input and output white vertex, respectively. To specify that Γ has such an edge, we will write $\Gamma = \Gamma(x, y)_i$. This notation allows us to express the graph obtained from Γ by replacing x and y with x' and y' respectively, as $\Gamma(x', y')_i$. We will write $\Gamma(\emptyset, \emptyset)_i$ the graph obtained from Γ by replacing the separated edge $\beta(i)$ with a compact edge. We denote by $\partial^{(i)}(p_i, r_i) * \Gamma(r_i, q_i)_i$ or $\Gamma(p_i, r_i) * \partial^{(i)}(r_i, q_i)$ the composition (one point union) of two graphs at the univalent vertices on which r_i is attached, and let $\partial_{p_i r_i}^{(i)} \in \mathbb{Z}$ be the coefficient in $\partial^{(i)} p_i = \sum_{r_i} \partial_{p_i r_i}^{(i)} r_i$.

Proof of Lemma 6.1. We prove the assertion for $\vec{g} = (g, g^{(2)}, \dots, g^{(m)})$ and $\vec{g}' = (g', g^{(2)}, \dots, g^{(m)})$, where g and g' are two combinatorial propagators for $(C_*^{(1)}, \partial^{(1)})$. As mentioned in §C, there exists an endomorphism $h \in \text{End}_2(C_*^{(1)})$ such that $\partial^{(1)} h -$

$h\partial^{(1)} = g - g'$. Then the difference $\text{Tr}_{g,\dots}(\tilde{\gamma}_{2k,3k}) - \text{Tr}_{g',\dots}(\tilde{\gamma}_{2k,3k})$ equals

$$\begin{aligned}
& \text{Tr}_{g-g',\dots} \left[\sum_{\substack{\Gamma(p_1, q_1)_1 \\ i(p_1)=i(q_1)+1}} \# \mathcal{M}_{\Gamma(p_1, q_1)_1}(\vec{f}) \Gamma(p_1, q_1)_1 \right] \\
&= \text{Tr}_{\partial^{(1)}h - h\partial^{(1)},\dots} \left[\sum_{\Gamma(p_1, q_1)_1} \# \mathcal{M}_{\Gamma(p_1, q_1)_1}(\vec{f}) \Gamma(p_1, q_1)_1 \right] \\
&= \text{Tr}_{h,\dots} \left[\sum_{\Gamma(p_1, q_1)_1} \sum_{\substack{x_1 \in P_*^{(1)} \\ i(x_1)=i(p_1)+1}} \partial_{x_1 p_1}^{(1)} \cdot \# \mathcal{M}_{\Gamma(p_1, q_1)_1}(\vec{f}) \Gamma(x_1, q_1)_1 \right. \\
&\quad \left. - \sum_{\Gamma(p_1, q_1)_1} \sum_{\substack{y_1 \in P_*^{(1)} \\ i(y_1)=i(q_1)-1}} \partial_{q_1 y_1}^{(1)} \cdot \# \mathcal{M}_{\Gamma(p_1, q_1)_1}(\vec{f}) \Gamma(p_1, y_1)_1 \right] \tag{6.2} \\
&= \text{Tr}_{h,\dots} \left[\sum_{\Gamma(p_1, q_1)_1} \sum_{x_1} \# \mathcal{M}_{\partial^{(1)}(x_1, p_1) * \Gamma(p_1, q_1)_1}(\vec{f}) \Gamma(x_1, q_1)_1 \right. \\
&\quad \left. - \sum_{\Gamma(p_1, q_1)_1} \sum_{y_1} \# \mathcal{M}_{\Gamma(p_1, q_1)_1 * \partial^{(1)}(q_1, y_1)}(\vec{f}) \Gamma(p_1, y_1)_1 \right].
\end{aligned}$$

We show that (6.2) vanishes. We write $\vec{C}[j] = (C_*^{(1)}, \dots, \widehat{C}_*^{(j)}, \dots, C_*^{(m)})$ and $\vec{\eta}[j] = (\eta_1, \dots, \widehat{\eta}_j, \dots, \eta_m)$ for simplicity. If we define $d^* : \bigoplus_{j=1}^m \mathcal{G}_{n-1, m-1, \vec{\eta}[j]}(\vec{C}[j]) \rightarrow \mathcal{G}_{n, m, \vec{\eta}}(\vec{C})$ by the coefficient of $1 \otimes \Gamma$ in $\sum_{\Gamma' \in \mathcal{G}_{n, m, \vec{\eta}}(\vec{C})} \Gamma' \otimes d\Gamma'$, then $\text{Im } d^*$ is the span of the IHX-relation.

Let $p'_1, q'_1 \in P_*^{(1)}$ be such that $i(p'_1) = \ell$ and $i(q'_1) = \ell - 2$. Then we consider graphs of the form $\Gamma(p'_1, q'_1)_1$. We denote by $p_i = p_i(\Gamma(p'_1, q'_1)_1)$ and $q_i = q_i(\Gamma(p'_1, q'_1)_1)$ the critical points attached on the input and the output white vertex of the i -th edge of $\Gamma(p'_1, q'_1)_1$, respectively. By Proposition 6.2, the following expression vanishes:

$$\begin{aligned}
& \text{Tr}_{h,\dots} \left[\sum_{\substack{\Gamma(p'_1, q'_1)_1 \in \\ \mathcal{G}_{n, m, (2, 1, \dots, 1)}^0(\vec{C})}} \# \mathcal{M}_{(d+d')\Gamma(p'_1, q'_1)_1}(\vec{f}) \Gamma(p'_1, q'_1)_1 \right] \\
&= \text{Tr}_{h,\dots} \left[\sum_{\substack{\Gamma'(p'_1, q'_1)_1 \in \\ \text{Pj } \mathcal{G}_{n-1, m-1, (2, 1, \dots, 1)}^0[j](\vec{C}[j])}} \# \mathcal{M}_{\Gamma'(p'_1, q'_1)_1}(\vec{f}) d^* \Gamma'(p'_1, q'_1)_1 + \sum_{\substack{\Gamma(p'_1, q'_1)_1 \in \\ \mathcal{G}_{n, m, (2, 1, \dots, 1)}^0(\vec{C})}} \# \mathcal{M}_{d\Gamma(p'_1, q'_1)_1}(\vec{f}) \Gamma(p'_1, q'_1)_1 \right] \\
&= \text{Tr}_{h,\dots} \left[\sum_{\Gamma(p'_1, q'_1)_1} \left(\sum_{r'_1 \in P_{\ell-1}^{(1)}} (-1)^\ell \# \mathcal{M}_{\partial^{(1)}(p'_1, r'_1) * \Gamma(r'_1, q'_1)_1}(\vec{f}) \right. \right. \\
&\quad \left. \left. + (-1)^{\ell-1} \# \mathcal{M}_{\Gamma(p'_1, r'_1)_1 * \partial^{(1)}(r'_1, q'_1)}(\vec{f}) \right) \Gamma(p'_1, q'_1)_1 \right. \\
&\quad + \sum_{\Gamma(p'_1, q'_1)_1} \sum_{\substack{i \neq 1 \\ i \notin \text{Comp}(\Gamma(p'_1, q'_1)_1)}} \left(\sum_{r_i \in P_{i(p_i)-1}^{(i)}} (-1)^{i(p_i)-1} \# \mathcal{M}_{\partial^{(i)}(p_i, r_i) * \Gamma(p'_1, q'_1)_1(r_i, q_i)_i}(\vec{f}) \right. \\
&\quad \left. + \sum_{r_i \in P_{i(p_i)}^{(i)}} (-1)^{i(p_i)} \# \mathcal{M}_{\Gamma(p'_1, q'_1)_1(p_i, r_i) * \partial^{(i)}(r_i, q_i)}(\vec{f}) \right) \Gamma(p'_1, q'_1)_1 \\
&\quad \left. + \sum_{\Gamma(p'_1, q'_1)_1} \sum_{\substack{e \in \text{Comp}(\Gamma(p'_1, q'_1)_1) \\ e \neq 1}} \# \mathcal{M}_{d_e \Gamma(p'_1, q'_1)_1}(\vec{f}) \Gamma(p'_1, q'_1)_1 \right].
\end{aligned}$$

In this expression, the first line agrees with $(-1)^\ell$ times the part of (6.2) of $i(x_1) = i(y_1) = \ell - 1$. The vanishing of the last two lines can be shown as follows: for each

$p'_1, q'_1 \in P_*^{(1)}$ with $i(p'_1) = i(q'_1) + 2$ and for $i \neq 1$, we have

$$\begin{aligned}
& \mathrm{Tr}_{h, \dots, g^{(i)}, \dots} \left[\sum_{j=1}^3 \sum_{\substack{p_i \in P_j^{(i)} \\ q_i \in P_{j-1}^{(i)}}} \left(\sum_{r_i \in P_{j-1}^{(i)}} (-1)^{j-1} \# \mathcal{M}_{\partial^{(i)}(p_i, r_i) * \Gamma(p'_1, q'_1)_1(r_i, q_i)_i}(\vec{f}) \right. \right. \\
& \quad \left. \left. + \sum_{r_i \in P_j^{(i)}} (-1)^j \# \mathcal{M}_{\Gamma(p'_1, q'_1)_1(p_i, r_i)_i * \partial^{(i)}(r_i, q_i)}(\vec{f}) \Gamma(p'_1, q'_1)_1(p_i, q_i)_i \right] \\
&= \mathrm{Tr}_{h, \dots, \partial^{(i)}g^{(i)} + g^{(i)}\partial^{(i)}, \dots} \left[\sum_{j=0}^3 (-1)^j \sum_{p'_i, q'_i \in P_j^{(i)}} \# \mathcal{M}_{\Gamma(p'_1, q'_1)_1(p'_i, q'_i)_i}(\vec{f}) \Gamma(p'_1, q'_1)_1(p'_i, q'_i)_i \right] \\
&= \mathrm{Tr}_{h, \dots, \mathrm{id}, \dots} \left[\sum_{j=0}^3 (-1)^j \sum_{r'_i \in P_j^{(i)}} \# \mathcal{M}_{\Gamma(p'_1, q'_1)_1(r'_i, r'_i)_i}(\vec{f}) \Gamma(p'_1, q'_1)_1(r'_i, r'_i)_i \right].
\end{aligned}$$

This cancels with the corresponding term in

$$\mathrm{Tr}_{h, \dots} \left[\sum_{\substack{e \in \mathrm{Comp}(\Gamma(p'_1, q'_1)_1) \\ e \neq 1}} \# \mathcal{M}_{d_e \Gamma(p'_1, q'_1)_1}(\vec{f}) \Gamma(p'_1, q'_1)_1 \right].$$

This completes the proof. \square

7. Independence of 4-cobordism and sections on it.

7.1. Spin cobordism invariance of $Z_{2k, 3k}^{\mathrm{anomaly}}$. In this section we assume that M is a \mathbb{Z} -homology 3-sphere. We say that two compact spin 4-manifolds W and W' with $\partial W = \partial W' = M$ are *relatively spin cobordant* if there is a compact spin 5-manifold V with corners with $\partial V = (-W) \cup_{\partial} ([0, 1] \times M) \cup_{\partial} W'$ whose spin structure is an extension of those of $-W$ and W' .

PROPOSITION 7.1. *Let W and W' be two compact spin 4-manifolds with $\partial W = \partial W' = M$ and $\chi(W) = \chi(W') = 1$ as in Lemma 2.9 (1). If W and W' are relatively spin cobordant, then the following assertions hold.*

- (1) *There exists a framing τ_M of TM_0 such that the associated 4-framing τ'_M of Lemma 2.9 can be extended to 4-framings of both TW and TW' . Hence one can find sequences of GM sections $\vec{\gamma}_W \in \Gamma(T^v W)^{3k}$ and $\vec{\gamma}_{W'} \in \Gamma(T^v W')^{3k}$ with $\vec{\gamma}_W|_{M-U_\infty} = \vec{\gamma}_{W'}|_{M-U_\infty} = -\mathrm{grad} \vec{f}$.*
- (2) *For any such extensions $\vec{\gamma}_W$ and $\vec{\gamma}_{W'}$, which are generic in the sense of Proposition 2.12 (1), we have*

$$Z_{2k, 3k}^{\mathrm{anomaly}}(\vec{\gamma}_W) = Z_{2k, 3k}^{\mathrm{anomaly}}(\vec{\gamma}_{W'}). \quad (7.1)$$

Proof. (1) Put $X = (-W) \cup_g ([0, 1] \times M) \cup_{g'} W'$, where the gluing maps $g : -\partial W = -M \rightarrow \{0\} \times M$ and $g' : \partial W' = M \rightarrow \{1\} \times M$ are the natural ones. By assumption, we have $[X] = 0 \in \Omega_4^{\mathrm{spin}}$. There is a 5-dimensional compact spin manifold V with corners with $\partial V = X$ whose smooth structure near $[0, 1] \times M$ is isomorphic to that of $[0, 1] \times W$. Then TV restricts on the boundary to a vector bundle that is isomorphic to $\varepsilon^1 \oplus TX$.

By the isomorphism $\text{sign} : \Omega_4^{\text{spin}} \xrightarrow{\sim} 16\mathbb{Z}$ and by Hirzebruch's signature theorem $\text{sign } X = \frac{1}{3}\langle p_1(TX), [X] \rangle$ for X closed, it follows that

$$p_1(TW'; \tau'_M) - p_1(TW; \tau'_M) = \langle p_1(\varepsilon^1 \oplus TX), [X] \rangle = 3 \text{sign } X = 0$$

for any choice of τ_M . By choosing τ_M suitably, we may assume that $p_1(TW; \tau'_M) = p_1(TW'; \tau'_M) = 0$ by Lemma 2.9 (2). By Lemma 2.9 (2), such a 4-framing τ'_M extends to 4-framings on both W and W' .

(2) Since the 4-framings τ_W and $\tau_{W'}$ obtained in (1) above are extensions of τ'_M , they can be trivially extended to a sub 4-framing τ_X of $\varepsilon^1 \oplus TX$ by the product structure of $[0, 1] \times M$. The sub 3-framing of τ_X whose restriction to $\{0\} \times (M - U'_\infty)$ agrees with τ_M spans a rank 3 subbundle $T^v X$ of $\varepsilon^1 \oplus TX$. Then there is a piecewise smooth GM sections $\vec{\gamma}_X$ of $T^v X$, which is a gluing of $\vec{\gamma}_W, \vec{\gamma}_{W'}$ and $\text{pr}^{-1}\vec{\gamma}_W|_{M-U'_\infty} \in \Gamma(T^v([0, 1] \times (M - U'_\infty)))^{3k}$ together at the boundary. By definition of $Z_{2k,3k}^{\text{anomaly}}$,

$$Z_{2k,3k}^{\text{anomaly}}(\vec{\gamma}_X) = Z_{2k,3k}^{\text{anomaly}}(\vec{\gamma}_{W'}) - Z_{2k,3k}^{\text{anomaly}}(\vec{\gamma}_W). \tag{7.2}$$

Then Lemma 7.2 below completes the proof. \square

LEMMA 7.2. *Let X and $\vec{\gamma}_X$ be as in the proof of Proposition 7.1 (2). Then we have $Z_{2k,3k}^{\text{anomaly}}(\vec{\gamma}_X) = 0$.*

We use the following lemma in the proof of Lemma 7.2.

LEMMA 7.3. *Let X be as in the proof of Proposition 7.1 (2) and τ_X be as above. Then $X \amalg X$ bounds a compact connected parallelizable 5-manifold V on which the stabilization of the 4-framing $\tau_X \amalg \tau_X$ extends as a 5-framing.*

Proof. Since X is spin null-cobordant, there exists a compact connected spin 5-manifold V with corners with $\partial V = X$. We first consider the obstruction to extending the stable framing $n \oplus \tau_X$ of $\varepsilon^1 \oplus TX$ to a 5-framing on TV , where n is the unit vector field normal to the span of τ_X with respect to a metric of V .

Since V is spin and since $\pi_2(SO_5) = 0$ and $\pi_3(SO_5) \cong \mathbb{Z}$, the first obstruction $\mathfrak{o}_1(V; n \oplus \tau_X)$ to the extension lies in the group $H^4(V, \partial V; \pi_3(SO_5)) \cong H_1(V; \mathbb{Z})$. We shall see that we may assume that this group is trivial after changing V by surgery. It is easy to see that any class in $H_1(V; \mathbb{Z})$ can be realized by an embedding $f : S^1 \rightarrow \text{Int } V$. Since V is oriented, the normal bundle N_f of the image of f is trivial. By a surgery along a framed embedding (f, τ_f) , i.e., attaching of a 6-dimensional 2-handle along a tubular neighborhood of $\text{Im } f$ through the trivialization, the homology class $[f]$ can be eliminated. Moreover, by replacing the 4-framing τ_f suitably, we may assume that the resulting 5-manifold of the surgery is spin since $\pi_1(SO_4) \rightarrow \pi_1(SO_5)$ and $\pi_1(SO_4) \rightarrow \pi_1(SO_6)$ are isomorphisms. Namely, choose a 5-framing τ_2 on an open neighborhood U of the 2-skeleton of a CW structure on V . We may assume after an isotopy that the image of f is included in U . Since $\pi_1(SO_5, SO_4) = 0$, τ_2 can be deformed to a 5-framing τ'_2 whose restriction to $\text{Im } f$ consists of tangent vectors of f and a normal 4-framing of $\text{Im } f$. The obstruction to extending a stabilization of τ'_2 to a 6-framing on the 2-handle $D^2 \times D^4$ lies in $H^2(D^2, \partial D^2; \pi_1(SO_6)) \cong \mathbb{Z}_2$, which can be removed by a $\pi_1(SO_4)$ -twist of the attaching map. Since $\pi_2(SO_6, SO_5) = 0$, the 6-framing on the 2-handle can be modified so that its restriction to the 2-skeleton of the boundary of the 6-dimensional 2-handle is a stabilization of a 5-framing. Now the 2-skeleton of the result of the surgery is framed. Hence the result of the surgery is spin again.

Now we assume $H_1(V; \mathbb{Z}) = 0$ by doing surgeries as above if necessary. Then the next obstruction $\mathfrak{o}_2(V; n \oplus \tau_X)$ for the extension lies in the group $H^5(V, \partial V; \pi_4(SO_5)) \cong \mathbb{Z}_2$ since $\pi_4(SO_5) = \mathbb{Z}_2$. To eliminate $\mathfrak{o}_2(V; n \oplus \tau_X)$, we consider the connected sum $V' = V \# V$ taken between the interiors. Then one can check that the obstruction $\mathfrak{o}_2(V'; n \oplus \tau_X \amalg n \oplus \tau_X) \in H^5(V', \partial V'; \pi_4(SO_5))$ vanishes in any case. This completes the proof. \square

Proof of Lemma 7.2. We prove $Z_{2k, 3k}^{\text{anomaly}}(\vec{\gamma}_X) = 0$ by constructing cobordisms of moduli spaces. Let V be a compact parallelizable 5-manifold with $\partial V = X \amalg X$ as in Lemma 7.3. Roughly, we will construct 1-dimensional moduli spaces $\mathcal{M}_\Gamma^{\text{local}}(\vec{\gamma})$ in a fiber bundle over V for each 3-valent graph Γ and we will see that

$$2Z_{2k, 3k}^{\text{anomaly}}(\vec{\gamma}_X) = \sum_{\Gamma \in \mathcal{G}_{2k, 3k}} \# \partial \overline{\mathcal{M}}_\Gamma^{\text{local}}(\vec{\gamma})[\Gamma] = 0.$$

Since the replacement of X with $X \amalg X$ and V with $V \# V$ changes $Z_{2k, 3k}^{\text{anomaly}}(\vec{\gamma}_X)$ just by a multiple of 2, it is enough for our purpose to assume that the obstruction $\mathfrak{o}_2(V; n \oplus \tau_X)$ vanishes in advance. Because of this we assume for simplicity that we have a framed 5-manifold (V, τ_V) that extends $(X, n \oplus \tau_X)$.

We shall now define the moduli space $\mathcal{M}_\Gamma^{\text{local}}$ extended over V . Let Γ be a labeled graph in $\mathcal{G}_{2k, 3k}^0$. Since we assume that the 5-framing τ_V extends $n \oplus \tau_X$, we have a sub 3-framing of τ_V that is an extension of the 3-framing of $T^v X$ and it spans a rank 3 subbundle $T^v V$ of TV . Moreover by Lemma 2.10 there is a GM extension $\vec{\gamma} = (\gamma_1, \dots, \gamma_{3k}) \in \Gamma(T^v V)^{3k}$ of $\vec{\gamma}_X$. Since for each j , $\Sigma(\gamma_j)$ is a compact 2-submanifold of V , we may arrange that $\Sigma(\gamma_j)$'s are disjoint from each other by a general position argument. Then we consider the blow-up $q: \overline{V} \rightarrow V$, where

$$\overline{V} = B\ell(V, \amalg_{\ell=1}^{3k} \Sigma(\gamma_\ell)).$$

We identify $\text{Int } \overline{V}$ with $V - \amalg_{\ell} \Sigma(\gamma_\ell)$ by q . Consider the pullback bundle q^*TV over \overline{V} and we set $T^v \overline{V} = q^*T^v V$. Note that $T^v \overline{V}$ is not a subbundle of $T\overline{V}$. We identify the total space of the $\overline{C}_{2k}^{\text{local}}(\mathbb{R}^3)$ -bundle associated to $T^v \overline{V}$ with $\overline{V} \times \overline{C}_{2k}^{\text{local}}(\mathbb{R}^3)$ via the trivialization τ_V . The nowhere zero sections $\gamma_1, \dots, \gamma_{3k}$ of $T^v(V - \amalg_{\ell} \Sigma(\gamma_\ell))$ extends smoothly to nowhere zero sections of $T^v \overline{V}$. We denote by $\overline{\Theta}_\ell(\gamma_\ell)$ the closure of $\Theta_\ell(\gamma_\ell)$ in $\overline{V} \times \overline{C}_{2k}^{\text{local}}(\mathbb{R}^3)$, which is a compact oriented submanifold with boundary. Then we may define the compact moduli space

$$\overline{\mathcal{M}}_\Gamma^{\text{local}}(\vec{\gamma}) = \bigcap_{\ell=1}^{3k} \overline{\Theta}_\ell(\gamma_\ell) \subset \overline{V} \times \overline{C}_{2k}^{\text{local}}(\mathbb{R}^3). \quad (7.3)$$

We shall see that this gives a desired 1-cobordism. We need two lemmas.

CLAIM 1. *After a C^0 -small perturbation of $\vec{\gamma}$ in $\Gamma(T^v V)^{3k}$ without affecting the general (disjoint) positions for $\Sigma(\gamma_j)$'s, we may arrange that $\overline{\mathcal{M}}_\Gamma^{\text{local}}(\vec{\gamma})$ is a compact smooth 1-submanifold of $\overline{V} \times \overline{C}_{2k}^{\text{local}}(\mathbb{R}^3)$ and that the 1-manifold $\overline{\mathcal{M}}_\Gamma^{\text{local}}(\vec{\gamma})$ is transversal to $\partial \overline{V} \times \overline{C}_{2k}^{\text{local}}(\mathbb{R}^3)$.*

Proof. The restriction for the singularities of GM sections γ_j given in §2.8.2 is used here. Let Γ' be the graph obtained from Γ by replacing $E(\Gamma)$ with $E(\Gamma) - \{\beta(j)\}$, let $V_j = V - \amalg_{\ell \neq j} \Sigma(\gamma_\ell)$ and $\overline{V}_j = B\ell(V, \amalg_{\ell \neq j} \Sigma(\gamma_\ell))$. Let $\pi' : \overline{V} \times \overline{C}_{2k}^{\text{local}}(\mathbb{R}^3) \rightarrow \overline{V}$

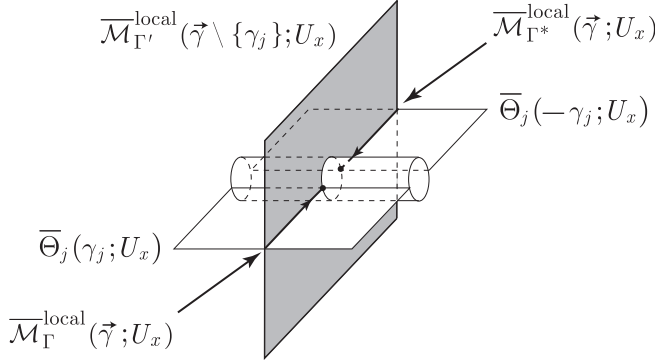
 FIG. 5. The intersection in $\pi_j'^{-1}(Bl(U_x, U_x \cap \Sigma(\gamma_i)))$

and $\pi_j' : \overline{V}_j \times \overline{\mathcal{C}}_{2k}^{\text{local}}(\mathbb{R}^3) \rightarrow \overline{V}_j$ be the projections. Then as mentioned in the proof of Proposition 2.12 (1), $\overline{\mathcal{M}}_{\Gamma'}^{\text{local}}(\tilde{\gamma} \setminus \{\gamma_j\})$ is a submanifold of $\overline{V}_j \times \overline{\mathcal{C}}_{2k}^{\text{local}}(\mathbb{R}^3)$ of codimension $6k - 2$, i.e., 3-dimensional, and we may define its compactification $\overline{\overline{\mathcal{M}}}_{\Gamma'}^{\text{local}}(\tilde{\gamma} \setminus \{\gamma_j\})$ as the closure of $\overline{\mathcal{M}}_{\Gamma'}^{\text{local}}(\tilde{\gamma} \setminus \{\gamma_j\})$ in $\overline{V}_j \times \overline{\mathcal{C}}_{2k}^{\text{local}}(\mathbb{R}^3)$.

We denote by $\overline{\overline{\mathcal{M}}}_{\Gamma'}^{\text{local}}(\tilde{\gamma} \setminus \{\gamma_j\}; \overline{V})$ the closure of $\overline{\mathcal{M}}_{\Gamma'}^{\text{local}}(\tilde{\gamma} \setminus \{\gamma_j\}) \cap \pi'^{-1}(V - \coprod_{\ell=1}^{3k} \Sigma(\gamma_\ell))$ in $\overline{V} \times \overline{\mathcal{C}}_{2k}^{\text{local}}(\mathbb{R}^3)$. This can be obtained from $\overline{\overline{\mathcal{M}}}_{\Gamma'}^{\text{local}}(\tilde{\gamma} \setminus \{\gamma_j\})$ by blowing-up $\pi'^{-1}\Sigma(\gamma_j)$ in $\overline{V}_j \times \overline{\mathcal{C}}_{2k}^{\text{local}}(\mathbb{R}^3)$. Then we have

$$\overline{\overline{\mathcal{M}}}_{\Gamma}^{\text{local}}(\tilde{\gamma}) = \overline{\Theta}_j(\gamma_j) \cap \overline{\overline{\mathcal{M}}}_{\Gamma'}^{\text{local}}(\tilde{\gamma} \setminus \{\gamma_j\}; \overline{V}) \subset \overline{V} \times \overline{\mathcal{C}}_{2k}^{\text{local}}(\mathbb{R}^3).$$

$\overline{\overline{\mathcal{M}}}_{\Gamma}^{\text{local}}(\tilde{\gamma})$ may have boundary points on $\pi'^{-1}q^{-1}(\Sigma(\gamma_j))$. Such boundary points cannot always be avoided since the 3-manifold $\overline{\overline{\mathcal{M}}}_{\Gamma'}^{\text{local}}(\tilde{\gamma} \setminus \{\gamma_j\})$ may intersect the codimension 3 submanifold $\pi_j'^{-1}(\Sigma(\gamma_j))$ of $\overline{V}_j \times \overline{\mathcal{C}}_{2k}^{\text{local}}(\mathbb{R}^3)$. After a small perturbation of γ_j in a small neighborhood of $\Sigma(\gamma_j)$, we may arrange that the intersection of the two submanifolds is transversal and that $\pi_j'(\overline{\overline{\mathcal{M}}}_{\Gamma'}^{\text{local}}(\tilde{\gamma} \setminus \{\gamma_j\}))$ and $\Sigma(\gamma_j)$ are transversal.

We shall give a local description of $\overline{\overline{\mathcal{M}}}_{\Gamma'}^{\text{local}}(\tilde{\gamma} \setminus \{\gamma_j\}; \overline{V})$ near the transversal intersection. Take a point $x \in \overline{\overline{\mathcal{M}}}_{\Gamma'}^{\text{local}}(\tilde{\gamma} \setminus \{\gamma_j\}) \cap \pi_j'^{-1}(\Sigma(\gamma_j))$ and a small open neighborhood U'_x of x in $\overline{V}_j \times \overline{\mathcal{C}}_{2k}^{\text{local}}(\mathbb{R}^3)$ so that U'_x contains exactly one intersection point. Let $U_x = \pi_j'(U'_x)$. After a suitable C^0 -small perturbation of $\tilde{\gamma} \setminus \{\gamma_j\}$ in a small neighborhood of $\Sigma(\gamma_j)$, we may arrange that

- (i) $\pi_j'(x)$ is a Morse singularity of γ_j and $U_x \cap \Sigma^2(\gamma_j) = \emptyset$,
- (ii) $\pi_j'(\overline{\overline{\mathcal{M}}}_{\Gamma'}^{\text{local}}(\tilde{\gamma} \setminus \{\gamma_j\}))$ is tangent to $T^v\overline{V}_j$ at $\pi_j'(x)$. (This is possible since $\Sigma(\gamma_j)$ is transversal to both $T^v\overline{V}_j$ and $\pi_j'(\overline{\overline{\mathcal{M}}}_{\Gamma'}^{\text{local}}(\tilde{\gamma} \setminus \{\gamma_j\}))$.)

We consider the blow-up $Bl(U_x, U_x \cap \Sigma(\gamma_j))$ and let

$$\overline{\overline{\mathcal{M}}}_{\Gamma'}^{\text{local}}(\tilde{\gamma} \setminus \{\gamma_j\}; U_x) = \overline{\overline{\mathcal{M}}}_{\Gamma'}^{\text{local}}(\tilde{\gamma} \setminus \{\gamma_j\}) \cap \pi_j'^{-1}(U_x - \Sigma(\gamma_j)) \quad (\text{the closure})$$

in $Bl(U_x, U_x \cap \Sigma(\gamma_j)) \times \overline{\mathcal{C}}_{2k}^{\text{local}}(\mathbb{R}^3)$. Since $\overline{\overline{\mathcal{M}}}_{\Gamma'}^{\text{local}}(\tilde{\gamma} \setminus \{\gamma_j\})$ is transversal to $\pi_j'^{-1}(\Sigma(\gamma_j)) \cap U'_x$, $\overline{\overline{\mathcal{M}}}_{\Gamma'}^{\text{local}}(\tilde{\gamma} \setminus \{\gamma_j\}; U_x)$ is a submanifold of $Bl(U_x, U_x \cap \Sigma(\gamma_j)) \times \overline{\mathcal{C}}_{2k}^{\text{local}}(\mathbb{R}^3)$ with boundary that meets $\partial Bl(U_x, U_x \cap \Sigma(\gamma_j)) \times \overline{\mathcal{C}}_{2k}^{\text{local}}(\mathbb{R}^3)$ transversally.

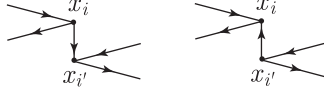

FIG. 6.

On the other hand, $\Theta_j(\gamma_j) \subset (V - \coprod_{\ell=1}^{3k} \Sigma(\gamma_\ell)) \times \overline{C}_{2k}^{\text{local}}(\mathbb{R}^3)$ has the closure $\overline{\Theta}_j(\gamma_j; U_x)$ in $B\ell(U_x, U_x \cap \Sigma(\gamma_j)) \times \overline{C}_{2k}^{\text{local}}(\mathbb{R}^3)$ that is a submanifold with boundary that meets $\partial B\ell(U_x, U_x \cap \Sigma(\gamma_j)) \times \overline{C}_{2k}^{\text{local}}(\mathbb{R}^3)$ transversally since $U_x \cap \Sigma(\gamma_j)$ consists only of Morse singularities. By the assumption (ii), the intersection of $\overline{\Theta}_j(\gamma_j; U_x)$ and $\overline{\mathcal{M}}_{\Gamma'}^{\text{local}}(\vec{\gamma} \setminus \{\gamma_j\}; U_x)$ is transversal even on the boundary and forms a 1-submanifold of $B\ell(U_x, U_x \cap \Sigma(\gamma_j)) \times \overline{C}_{2k}^{\text{local}}(\mathbb{R}^3)$ with boundary. Let

$$\overline{\mathcal{M}}_{\Gamma}^{\text{local}}(\vec{\gamma}; U_x) = \overline{\Theta}_j(\gamma_j; U_x) \pitchfork \overline{\mathcal{M}}_{\Gamma'}^{\text{local}}(\vec{\gamma} \setminus \{\gamma_j\}; U_x).$$

See Fig. 5 for a schematic illustration. $\overline{\mathcal{M}}_{\Gamma}^{\text{local}}(\vec{\gamma}; U_x)$ is a local model of $\overline{\mathcal{M}}_{\Gamma}^{\text{local}}(\vec{\gamma})$. Clearly $\overline{\mathcal{M}}_{\Gamma}^{\text{local}}(\vec{\gamma}; U_x)$ is transversal to $\partial B\ell(U_x, U_x \cap \Sigma(\gamma_j)) \times \overline{C}_{2k}^{\text{local}}(\mathbb{R}^3)$. By similar arguments for other intersection points x and for other j , we may arrange that $\overline{\mathcal{M}}_{\Gamma}^{\text{local}}(\vec{\gamma})$ is transversal to the boundary. \square

CLAIM 2. *If $\vec{\gamma}$ is as in Claim 1, then the boundary contribution of $\overline{\mathcal{M}}_{\Gamma}^{\text{local}}(\vec{\gamma})$ at the ‘inner’ boundary $(\partial\overline{V} - \partial V) \times \overline{C}_{2k}^{\text{local}}(\mathbb{R}^3)$ is canceled with that of some other graph Γ^* by symmetry, namely,*

$$\#\partial\overline{\mathcal{M}}_{\Gamma}^{\text{local}}(\vec{\gamma}; U_x) [\Gamma] + \#\partial\overline{\mathcal{M}}_{\Gamma^*}^{\text{local}}(\vec{\gamma}; U_x) [\Gamma^*] = 0.$$

Proof. By the assumption (ii) in the proof of Claim 1, the boundary of $\pi'_j(\overline{\mathcal{M}}_{\Gamma}^{\text{local}}(\vec{\gamma}; U_x))$ lies in the fiber S_x^2 of the unit sphere bundle $S(T^vV)$ at $\pi'_j(x)$. Let Γ^* denote the graph obtained from Γ by reversing the orientation of the edge labeled j . Notice that there are individual terms for Γ and Γ^* in the formula of $Z_{2k,3k}^{\text{anomaly}}(\vec{\gamma}_X)$ in Definition 2.11. Since $\overline{\mathcal{M}}_{\Gamma}^{\text{local}}(\vec{\gamma}; U_x) \amalg \overline{\mathcal{M}}_{\Gamma^*}^{\text{local}}(\vec{\gamma}; U_x)$ is transversal to $\partial B\ell(U_x, U_x \cap \Sigma(\gamma_j)) \times \overline{C}_{2k}^{\text{local}}(\mathbb{R}^3)$ by Claim 1 and since on a neighborhood of $\Sigma(\gamma_j)$ there is a symmetry between the moduli spaces $\overline{\mathcal{M}}_{\Gamma}^{\text{local}}(\vec{\gamma}; U_x)$ and $\overline{\mathcal{M}}_{\Gamma^*}^{\text{local}}(\vec{\gamma}; U_x)$ by the assumption (i) and by the symmetry of the standard model around a Morse point, the intersection of $\pi'_j(\overline{\mathcal{M}}_{\Gamma}^{\text{local}}(\vec{\gamma}; U_x) \amalg \overline{\mathcal{M}}_{\Gamma^*}^{\text{local}}(\vec{\gamma}; U_x))$ with $\partial B\ell(U_x, U_x \cap \Sigma(\gamma_j))$ consists of two points in S_x^2 that are in an antipodal position. Hence one may see that

$$\begin{aligned} & \#\partial\overline{\mathcal{M}}_{\Gamma}^{\text{local}}(\vec{\gamma}; U_x) [\Gamma] + \#\partial\overline{\mathcal{M}}_{\Gamma^*}^{\text{local}}(\vec{\gamma}; U_x) [\Gamma^*] \\ &= \left(\#\partial\overline{\mathcal{M}}_{\Gamma}^{\text{local}}(\vec{\gamma}; U_x) - \#\partial\overline{\mathcal{M}}_{\Gamma^*}^{\text{local}}(\vec{\gamma}; U_x) \right) [\Gamma] \\ &= \left(\#\partial\overline{\mathcal{M}}_{\Gamma}^{\text{local}}(\vec{\gamma}; U_x) - \#\partial\overline{\mathcal{M}}_{\Gamma}^{\text{local}}(\vec{\gamma}; U_x) \right) [\Gamma] = 0. \end{aligned}$$

Here, the second equality follows by the facts that the symmetry reverses the orientation of $\overline{\Theta}_j$, and that the inward normal vectors at $\partial\overline{\mathcal{M}}_{\Gamma}^{\text{local}}(\vec{\gamma}; U_x)$ and $\partial\overline{\mathcal{M}}_{\Gamma^*}^{\text{local}}(\vec{\gamma}; U_x)$ are opposite. See Fig. 5 and 6. \square

We continue the proof of Lemma 7.2. Now by Claims 1 and 2,

$$0 = \sum_{\Gamma \in \mathcal{G}_{2k,3k}^0} \# \partial \overline{\mathcal{M}}_{\Gamma}^{\text{local}}(\vec{\gamma})[\Gamma] = Z_{2k,3k}^{\text{anomaly}}(\vec{\gamma}_X) - \sum_{\Gamma \in \mathcal{G}_{2k,3k}^0} \# \overline{\mathcal{M}}_{d\Gamma}^{\text{local}}(\vec{\gamma})[\Gamma].$$

The second term in the RHS vanishes by the IHX relation of $\mathcal{A}_{2k,3k}$. \square

REMARK 7.4. Proposition 7.1 shows that $Z_{2k,3k}^{\text{anomaly}}(\vec{\gamma}_W)$ does not depend on the GM extension $\vec{\gamma}_W$ of $-\text{grad } \vec{f}$. However, we fixed a diffeomorphism $\varphi_{\infty} : U'_{\infty} \rightarrow U_{\infty}$ and extension τ'_M of $n \oplus \tau_M$, so we must check that $Z_{2k,3k}^{\text{anomaly}}(\vec{\gamma}_W)$ does not depend on these choices. It will be checked in Lemma 10.1.

7.2. Well-definedness of the correction term. To prove Proposition 2.12 (2), we consider general pairs of spin 4-manifolds W and W' with $\partial W = \partial W' = M$, $\chi(W) = \chi(W') = 1$ which may not be relatively spin cobordant. We choose 3-framings σ_M and τ_M on TM_0 so that

$$p_1(TW; \tau'_M) = p_1(TW'; \sigma'_M) = 0,$$

which are canonical up to homotopy. Then by Lemma 2.9, τ'_M extends to a 4-framing of W and σ'_M extends to a 4-framing of W' . But τ_M may not be homotopic to σ_M , so we may not have a stable framing of $\varepsilon^1 \oplus TX$, $X = (-W) \cup_g ([0, 1] \times M) \cup_{g'} W'$, namely, X may be just almost parallelizable. Although we do not have a stable framing of $\varepsilon^1 \oplus TX$, we have a rank 3 (possibly nontrivial) subbundle $T^v X$ of $\varepsilon^1 \oplus TX$ that agrees with $\text{pr}_1^* TM_0$ on $[0, 1] \times M_0$, which extends those spanned by σ_M and τ_M . By Lemma 2.10, there exists a GM sections $\vec{\gamma}_X \in \Gamma(T^v X)^{3k}$ extending $-\text{grad } \vec{f}$ and one can define $Z_{2k,3k}^{\text{anomaly}}(\vec{\gamma}_X) \in \mathcal{A}_{2k,3k}$.

More generally, one can also define $Z_{2k,3k}^{\text{anomaly}}(\vec{\gamma}_X)$ for any almost parallelizable, closed, connected, spin 4-manifold⁴ with $\chi(X) = 2$. Namely, by a straightforward analogue of [KM, Theorem 2.2], the restriction of a framing on $X - \text{Int}([0, 1] \times D^3)$ to $\partial([0, 1] \times D^3)$ can be deformed to a framing of the form $\text{pr}_1^{-1} \tau_{D^3} \oplus \text{pr}_2^{-1} \tau_{[0,1]}$ if and only if $\chi(X) = 2$.

Let $\Omega_4^{\text{spin}}(2)$ denote the set of spin cobordism classes of closed, connected, spin 4-manifolds X with $\chi(X) = 2$. By the same argument as in the proof of Lemma 7.2, one may see that the assignment $X \mapsto Z_{2k,3k}^{\text{anomaly}}(\vec{\gamma}_X)$ for generic $\vec{\gamma}_X$ defines a well-defined map

$$Z_{2k,3k}^{\text{anomaly}} : \Omega_4^{\text{spin}}(2) \rightarrow \mathcal{A}_{2k,3k}.$$

The set $\Omega_4^{\text{spin}}(2)$ has a group structure given by connected sum. More precisely, if X is a closed, connected, spin 4-manifold with $\chi(X) = 2$, then there is a framing on $X - [0, 1] \times D^3$. If X' is another closed, connected, spin 4-manifold with $\chi(X') = 2$, then by forming the boundary connected sum $X - [0, 1] \times D^3 \natural X' - [0, 1] \times D^3$ and capping by $[0, 1] \times D^3$ along the boundary in a natural way, we will obtain an almost parallelizable, closed, connected, spin 4-manifold X'' with $\chi(X'') = 2$ that is diffeomorphic to $X \# X'$. This defines an abelian group structure on $\Omega_4^{\text{spin}}(2)$ on which the inverse of X is given by $-X$.

⁴Note that any compact connected spin 4-manifold is almost parallelizable. Thus the assumption of almost parallelizability is unnecessary.

LEMMA 7.5. *The map $Z_{2k,3k}^{\text{anomaly}} : \Omega_4^{\text{spin}}(2) \rightarrow \mathcal{A}_{2k,3k}$ is a group homomorphism.*

Proof. If $[X] = 0 \in \Omega_4^{\text{spin}}(2)$, then we have $0 = \text{sign } X = \frac{1}{3} \langle p_1(\varepsilon_X^1 \oplus TX), [X] \rangle$ and $\chi(X) = 2$, thus by Lemma 2.9, the stabilization of the 4-framing on $\partial X - [0, 1] \times D^3$ induced from that of $X - [0, 1] \times D^3$ extends over X . Namely, X is stably parallelizable. Then by the same argument as in the proof of Lemma 7.2, we have $Z_{2k,3k}^{\text{anomaly}}(\vec{\gamma}_X) = 0$ for any generic GM sections $\vec{\gamma}_X \in (\Gamma(T^v X))^{3k}$. The additivity of $Z_{2k,3k}^{\text{anomaly}}$ follows from the fact that $Z_{2k,3k}^{\text{anomaly}}$ is invariant under spin cobordism as shown in Proposition 7.1, and that $X \amalg X'$ and $X \# X'$ are spin cobordant. Hence $Z_{2k,3k}^{\text{anomaly}}$ is a homomorphism. \square

Proof of Proposition 2.12 (2). By Lemma 7.5, $Z_{2k,3k}^{\text{anomaly}}$ is a restriction of a group homomorphism $\Omega_4^{\text{spin}} \rightarrow \mathcal{A}_{2k,3k}$. So there exists a constant $\mu_k \in \mathcal{A}_{2k,3k}$ such that

$$Z_{2k,3k}^{\text{anomaly}}(\vec{\gamma}_X) = \mu_k \text{sign } X,$$

for $X = (-W) \cup_g ([0, 1] \times M) \cup_{g'} W'$. By (7.2) and by the additivity of the signature,

$$Z_{2k,3k}^{\text{anomaly}}(\vec{\gamma}_{W'}) - Z_{2k,3k}^{\text{anomaly}}(\vec{\gamma}_W) = \mu_k \text{sign } X = \mu_k \text{sign } W' - \mu_k \text{sign } W.$$

This completes the proof. \square

8. Moduli space of gradient flow graphs in 1-parameter family. The next two sections contain preliminaries for the proof of the main Theorem 2.13, which are 1-parameter analogues of the results in §3 to §5. We consider generic 1-parameter families of smooth functions $f_s : M_0 \rightarrow \mathbb{R}$ and metrics μ_s on M_0 parametrized by $s \in [0, 1]$, and see what happens to the moduli spaces of flow graphs during the homotopy $\{(f_s, \mu_s)\}_{s \in [0, 1]}$. We shall extend the definition of the moduli spaces $\mathcal{M}_2(f)$ and $\mathcal{M}_\Gamma(\vec{f})$ to those for 1-parameter families (§8.2) and give their compactifications to smooth manifolds with corners. Proofs of some lemmas that are analogous to the lemmas appeared previously will be a bit brief to make the paper not too long.

8.1. Bifurcations in 1-parameter family of smooth functions and metrics. Let $f, f' : M_0 \rightarrow \mathbb{R}$ be two Morse functions. Then there exists a smooth 1-parameter family $\{f_s : M_0 \rightarrow \mathbb{R}\}_{s \in [0, 1]}$ of functions on M_0 such that $f_0 = f$ and $f_1 = f'$ and f_s is standard near ∞_M with respect to a chart $\varphi_{\infty_s} : U'_{\infty_s} \rightarrow U_\infty$ ($\infty_M \in U'_{\infty_s}$), where we say that a 1-parameter family $\{f_s\}_{s \in [0, 1]}$ is smooth if the map $F : [0, 1] \times M_0 \rightarrow \mathbb{R}$, $F(s, x) = f_s(x)$ is smooth. It is known that F can be chosen so that for all $s \in [0, 1]$, f_s does not have higher singularities.

LEMMA 8.1 ([Ce]). *Two Morse functions on a manifold can be connected by a smooth 1-parameter family of smooth functions with only Morse or birth-death (A_2) singularities.*

The proof of the lemma can be found in [Lau, §4.3].

In the following, we will often identify a smooth 1-parameter family $\{f_s\}_{s \in [a, b]}$ of functions on M_0 with the smooth map $F : [0, 1] \times M_0 \rightarrow \mathbb{R}$, $F(s, x) = f_s(x)$. Under this identification, we consider f_s as both a map $M_0 \rightarrow \mathbb{R}$ and a map $\{s\} \times M_0 \rightarrow \mathbb{R}$. We will consider $\mathcal{D}_p(f_s)$ etc as subsets of M_0 or $M_0 \times \{s\}$, depending on the context.

Let $\{(f_s, \mu_s)\}_{s \in [0, 1]}$ be a smooth 1-parameter family of smooth functions and metrics such that (f_0, μ_0) and (f_1, μ_1) are Morse–Smale. Here we say that the family $\{\mu_s\}_{s \in [0, 1]}$ of metrics is smooth if it is the restriction of a smooth metric on $[0, 1] \times M_0$

that is standard near $[0, 1] \times \infty_M$. We will sometimes call $s \in [0, 1]$ a *time* and we say that a time $s_0 \in [0, 1]$ is a *bifurcation* if (f_{s_0}, μ_{s_0}) is not Morse–Smale or not ordered.

LEMMA 8.2 ([HW](p. 42), Lemma 2.11 of [Hu]). *After a perturbation of $\{(f_s, \mu_s)\}_{s \in [0, 1]}$ fixing endpoints, we may arrange that there are finitely many bifurcation times in $[0, 1]$ each of which is one of the following.*

- (1) *Level exchange, i.e., a time where the order of the critical values changes.*
- (2) *Birth-death bifurcation, i.e., a time s where $\Sigma(f_s)$ consists of Morse singularities and one birth-death singularity.*
- (3) *i/i -intersection ([HW]), i.e., a time where a family of descending manifolds and a family of ascending manifolds of the same index i intersect transversally in $[0, 1] \times M$.*
- (4) *A time where the intersection of a descending manifold and an ascending manifold is not transversal.*

We may assume that no two different bifurcations overlap on a single time. (We will call such a 1-parameter family a generic 1-parameter family.)

At a bifurcation, the topologies of the moduli spaces $\mathcal{M}'(f_s; p_s, q_s)$, $p_s, q_s \in \Sigma(f_s)$, may change.

Lemma 8.2 can be proved as follows. By Lemma 8.1 and by definition of bifurcations, it is enough to prove (3) and (4) of the lemma in the case where f_s is ordered Morse for all $s \in [0, 1]$ (see Lemma 3.1 for the definition of ordered Morse function). Put $J = [0, 1]$. It suffices to prove that for a pair of critical loci $p = \{p_s\}_{s \in J}$ and $q = \{q_s\}_{s \in J}$, the submanifolds $\widetilde{\mathcal{A}}_p(f_J) = \bigcup_{s \in J} \mathcal{A}_{p_s}(f_s)$ and $\widetilde{\mathcal{D}}_q(f_J) = \bigcup_{s \in J} \mathcal{D}_{q_s}(f_s)$ of $J \times M_0$ can be made transversal. They are indeed submanifolds of $J \times M_0$ for a similar reason as the descending and ascending manifolds are submanifolds of M_0 . Namely, by the parametrized Morse lemma ([Ig2, Appendix]) one may see that they are submanifolds on a neighborhood of the critical locus and then extended by the gradient flow without changing its diffeomorphism type. By modifying the 1-parameter family $\{\mu_s\}_{s \in J}$ of metrics on M_0 suitably, one can show, by a similar argument as the proof of the genericity of the Morse–Smale condition (see e.g. [Pe]), that $\widetilde{\mathcal{A}}_p(f_J)$ ’s and $\widetilde{\mathcal{D}}_q(f_J)$ ’s intersect mutually transversal in the trivial M_0 -bundle over J after a fiberwise small perturbation of the metrics. Note that even if so, it may not be true that $\mathcal{A}_{p_s}(f_s)$ and $\mathcal{D}_{q_s}(f_s)$ are transversal for every s . If the transversality of $\mathcal{A}_{p_s}(f_s)$ and $\mathcal{D}_{q_s}(f_s)$ for $i(p_s) = i(q_s)$ fails, then s is of type (3). For other indices, the intersection $\mathcal{A}_p(f_J) \cap \mathcal{D}_q(f_J)$ is a submanifold of $J \times M_0$. Let \widetilde{L} be a level surface locus for f_J such that for each $s \in J$, $\widetilde{L} \cap (\{s\} \times M)$ is a level surface of f_s that lies between $f_s(p_s)$ and $f_s(q_s)$. We may assume that the map $\text{pr} : (\widetilde{\mathcal{A}}_p(f_J) \cap \widetilde{\mathcal{D}}_q(f_J)) \cap \widetilde{L} \rightarrow J$ induced from the projection $J \times M_0 \rightarrow J$ is Morse for every pair (p, q) of distinct critical loci⁵. There are finitely many⁶ critical values of pr , which are bifurcations of type (4).

We say that a 1-parameter family $(f_J, \mu_J) = \{(f_s, \mu_s)\}_{s \in J}$ of Morse pairs satisfies the *parametrized Morse–Smale condition* if for every pair (p, q) of critical loci of f_J the intersection of $\widetilde{\mathcal{A}}_p(f_J)$ and $\widetilde{\mathcal{D}}_q(f_J)$ is transversal.

⁵If $\widetilde{\mathcal{A}}_p(f_J)$ and $\widetilde{\mathcal{D}}_q(f_J)$ are transversal, then that $\mathcal{A}_{p_s}(f_s)$ and $\mathcal{D}_{q_s}(f_s)$ are transversal is equivalent to that s is a regular value of $\text{pr} : \widetilde{\mathcal{A}}_p(f_J) \cap \widetilde{\mathcal{D}}_q(f_J) \rightarrow J$. This can be checked by applying the formula $\dim V + W = \dim V + \dim W - \dim V \cap W$ for vector spaces twice.

⁶The finiteness is proved by using compactifications of $\widetilde{\mathcal{A}}_p(f_J)$ and $\widetilde{\mathcal{D}}_q(f_J)$ given later. Although we use Lemma 8.2 in the construction of the compactification, there is no problem in this because we do not use the finiteness of the bifurcations for the compactifications.

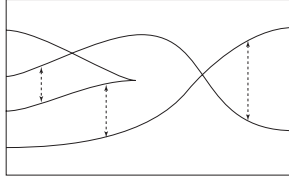

FIG. 7. Cerf's graphic equipped with the information of i/i -intersections

It is convenient to represent bifurcations in a 1-parameter family by the graph of critical values, equipped with the information of i/i -intersections. See Fig. 7 for an example. Such a diagram is called Cerf's *graphic* ([Ce]). In a graphic, a level exchange corresponds to a crossing of two curves, an i/i -intersection between a pair of critical points is represented by a dotted arrow, and a birth-death bifurcation corresponds to beaks.

8.2. Moduli space \mathcal{M}_Γ in 1-parameter family and transversality. Let $\{(f_s, \mu_s)\}_{s \in [0,1]}$ be a generic 1-parameter family. Let $J = [s_0, s_1]$ be a closed interval in $[0, 1]$ on which $\{(f_s, \mu_s)\}_{s \in J}$ does not have birth-death bifurcation. We consider a 1-parameter family $\vec{f}_s = (f_s, f_2, \dots, f_m)$, $s \in J$, and extend the definition of the moduli space $\mathcal{M}_\Gamma(\vec{f})$ to the family $\vec{f}_J = \{\vec{f}_s\}_{s \in J}$.

The moduli space $\mathcal{M}_\Gamma(\vec{f}_s)$ for a generic parameter $s \in J$ is defined similarly as $\mathcal{M}_\Gamma(\vec{f})$ by replacing f_1 in the definition of $\mathcal{M}_\Gamma(\vec{f})$ (§2.4) with f_s, μ_1 with μ_s and critical points with critical loci. For graphs Γ with $\dim \mathcal{M}_\Gamma < 0$ with respect to the formula of Proposition 2.4, the moduli space $\mathcal{M}_\Gamma(\vec{f}_s)$ is empty at a generic parameter s , but we will see that $\mathcal{M}_\Gamma(\vec{f}_s)$ may be non-empty at finitely many non-generic parameters in J if the formula of Proposition 2.4 gives $\dim \mathcal{M}_\Gamma(\vec{f}_s) = -1$.

PROPOSITION 8.3. *Let $\{(f_s, \mu_s)\}_{s \in J}$ be a generic 1-parameter family with no birth-death bifurcation as above and let \vec{C} be the sequence $(C^{(s_0)}, C^{(2)}, C^{(3)}, \dots, C^{(m)})$ of acyclic complexes, where $C^{(s_0)}$ is the Morse complex for (f_{s_0}, μ_{s_0}) . Suppose that $\Gamma \in \mathcal{G}_{n,m,\vec{\eta}}^0(\vec{C})$ has no bivalent vertex. For a generic choice of $\{(f_s, \mu_s)\}_{s \in J}$, the space $\mathcal{M}_\Gamma(\vec{f}_J) = \bigcup_{s \in J} \mathcal{M}_\Gamma(\vec{f}_s)$, $\vec{f}_J = \{(f_s, f_2, \dots, f_m)\}_{s \in J}$, is a smooth submanifold of $J \times C_n(M)$ of dimension $(n - m)d + \sum_{i=1}^m \eta_i + 1$.*

For simplicity, we only check the transversality on the moduli space $\mathcal{M}_\Gamma(\vec{f}_J)$ for the special graph

$$\Gamma = \begin{array}{c} p \circ \xrightarrow{(1)} 1 \\ \qquad \searrow \quad \nearrow \quad \searrow \quad \nearrow \\ \qquad \qquad \quad 2 \quad \quad \quad 3 \\ \qquad \qquad \quad \nearrow \quad \searrow \quad \nearrow \quad \searrow \\ q \circ \xrightarrow{(1)} 4 \end{array} \in \mathcal{G}_{4,6}^0(\vec{C}) \tag{8.1}$$

since other cases are similar. Suppose that $\vec{f}_{s_0} = (f_{s_0}, f_2, \dots, f_6) \in (C_{\varphi_\infty}^r(M_0))^6$ is generic in the sense of Proposition 2.4. We decompose Γ into two parts:

$$\Gamma' = \begin{array}{c} p \circ \xrightarrow{(1)} 1 \\ \qquad \searrow \quad \nearrow \\ \qquad \qquad \quad 4 \end{array}, \text{ and } \Gamma'' = \begin{array}{c} 1 \\ \quad \searrow \quad \nearrow \quad \searrow \quad \nearrow \\ \quad \quad \quad 2 \quad \quad \quad 3 \\ \quad \quad \quad \nearrow \quad \searrow \quad \nearrow \quad \searrow \\ 4 \end{array}.$$

The moduli space $\mathcal{M}_{\Gamma''}(\vec{f}'') \subset C_4(M)$, $\vec{f}'' = (f_2, \dots, f_6)$, is given by $\mathcal{M}_{\Gamma''}(\vec{f}'') = \text{pr}_1(\Phi_{\vec{f}''}^{-1}(\Delta''))$, where $\Phi_{\vec{f}''} : C_4(M) \times \mathbb{R}_+^5 \rightarrow M_0^9$ is defined by

$$\begin{aligned} \Phi_{\vec{f}''}(x_1, \dots, x_4, t_2, \dots, t_6) \\ = (x_1, x_2, \Phi_{f_2}^{t_2}(x_1), x_3, \Phi_{f_4}^{t_4}(x_1), \Phi_{f_5}^{t_5}(x_2), x_4, \Phi_{f_3}^{t_3}(x_2), \Phi_{f_6}^{t_6}(x_3)), \end{aligned}$$

and $\Delta'' = \{(x_1, x_2, x_2, x_3, x_3, x_3, x_4, x_4, x_4) ; x_1, x_2, x_3, x_4 \in M_0\}$. By the genericity of \vec{f}_{s_0} , we may assume that $\mathcal{M}_{\Gamma''}(\vec{f}'')$ is a submanifold of $C_4(M)$ of dimension $(4d + 5) + 4d - 9d = 5 - d$. On the other hand, the moduli space $\mathcal{M}_{\Gamma'}(f_J) = \bigcup_{s \in J} \mathcal{M}_{\Gamma'}(f_s)$ is given by the $(d + \eta_1 + 1)$ -dimensional manifold $\mathcal{N}_{pq}(f_J) = \bigcup_{s \in J} \mathcal{N}_{pq}(f_s) \subset J \times C_2(M)$. Then we have $\mathcal{M}_{\Gamma}(\vec{f}_J) = \tilde{\pi}_{14}^{-1}(\mathcal{M}_{\Gamma'}(f_J) \cap (J \times \mathcal{M}_{\Gamma''}(\vec{f}'')))$, where $\tilde{\pi}_{14} : J \times C_4(M) \rightarrow J \times C_2(M)$ is the projection $(s, x_1, x_2, x_3, x_4) \mapsto (s, x_1, x_4)$. By the transversality theorem, we may assume after a small perturbation like Lemma 4.1 of the family $\{(f_s, \mu_s)\}_{s \in J}$ that the intersection is transversal, and hence $\mathcal{M}_{\Gamma}(\vec{f}_J) = \bigcup_{s \in J} \mathcal{M}_{\Gamma}(f_s)$ is a submanifold of dimension $(d + \eta_1 + 1 + 2d) + (5 - d + 1) - (4d + 1) = -2d + (\eta_1 + 5) + 1$. If the first edge of Γ were a compact edge, then $\mathcal{M}_{\Gamma}(f_J)$ would be replaced with $\mathcal{M}_2(f_J) = \bigcup_{s \in J} \mathcal{M}_2(f_s)$.

8.3. Compactification of the moduli space \mathcal{M}_2 of trajectories in 1-parameter family of Morse pairs. Let $J \subset [0, 1]$ be a compact interval and let $\{(f_J, \mu_J)\}_{s \in J}$ be a generic 1-parameter family without birth-death bifurcation, namely, f_J is a 1-parameter family of Morse functions. We construct compactifications of the spaces

$$\mathcal{M}_2(f_J) = \bigcup_{s \in J} \mathcal{M}_2(f_s), \quad \mathcal{N}_{pq}(f_J) = \bigcup_{s \in J} \mathcal{N}_{pq}(f_s) \subset J \times M_0^2.$$

The goal of this subsection is to prove the following proposition.

PROPOSITION 8.4. *Let $(f_J, \mu_J) = \{(f_s, \mu_s)\}_{s \in J}$ be a generic 1-parameter family of Morse pairs that satisfies the parametrized Morse–Smale condition. There is a natural compactification $\overline{\mathcal{M}}_2(f_J)$ of $\mathcal{M}_2(f_J) = \bigcup_{s \in J} \mathcal{M}_2(f_s)$ such that*

- (1) *The complement of $\bar{b}^{-1}(\widehat{\Delta}_M)$ in $\overline{\mathcal{M}}_2(f_J)$, where $\bar{b} : \overline{\mathcal{M}}_2(f_J) \rightarrow M \times M$ is the smooth extension of the evaluation map $\mathcal{M}_2(f_J) \rightarrow M_0 \times M_0$, is a smooth manifold with corners.*
- (2) *The codimension k stratum of $\mathcal{M}_2(f_J) - \bar{b}^{-1}(\widehat{\Delta}_M)$ for $k \geq 1$ consists of families of k times broken trajectories and $\partial_{k-1} \overline{\mathcal{M}}_2(f_{\partial J})$, the codimension $k - 1$ stratum of $\overline{\mathcal{M}}_2(f_{\partial J}) - \bar{b}^{-1}(\widehat{\Delta}_M)$ in $\partial J \times M$.*

Let $\bar{b}_J : \overline{\mathcal{M}}_2(f_J) \rightarrow (J \times M) \times (J \times M)$ be the evaluation map with time, which is defined for a possibly broken trajectory γ in $\{s\} \times M$ with $\bar{b}(\gamma) = (x, y)$ to be $\bar{b}_J(\gamma) = (s, x) \times (s, y)$. For a critical locus $p = \{p_s\}_{s \in J}$ of f_J , we write

$$\mathcal{E}\widetilde{\mathcal{A}}_p(f_J) = \bar{b}_J^{-1}((J \times M) \times p), \quad \mathcal{E}\widetilde{\mathcal{D}}_p(f_J) = \bar{b}_J^{-1}(p \times (J \times M)).$$

Let $\bar{b}_{\mathcal{A}} : \mathcal{E}\widetilde{\mathcal{A}}_q(f_J) \rightarrow J \times M$ (resp. $\bar{b}_{\mathcal{D}} : \mathcal{E}\widetilde{\mathcal{D}}_p(f_J) \rightarrow J \times M$) be the map that assigns the initial endpoint (resp. terminal endpoint) of a possibly broken flow line. Let $\Delta_J \times M^2$ be the subset of $(J \times M)^2$ consisting of points of the form $(s, x) \times (s, y)$ and let

$$\overline{\mathcal{N}}_{pq}(f_J) = (\bar{b}_{\mathcal{A}} \times \bar{b}_{\mathcal{D}})^{-1}(\Delta_J \times M^2) \subset \mathcal{E}\widetilde{\mathcal{A}}_q(f_J) \times \mathcal{E}\widetilde{\mathcal{D}}_p(f_J).$$

Let $\bar{b}b : \mathcal{C}\widetilde{\mathcal{A}}_q(f_J) \times \mathcal{C}\widetilde{\mathcal{D}}_p(f_J) \rightarrow M \times M$ be the composition of $\bar{b}_{\mathcal{A}} \times \bar{b}_{\mathcal{D}}$ and the projection $(J \times M)^2 \rightarrow M \times M$. For subsets $\tilde{A}, \tilde{B} \subset J \times M$, let $\tilde{A} \times_J \tilde{B} = (\tilde{A} \times \tilde{B}) \cap (\Delta_J \times M^2)$ and let

$$\mathcal{M}_2(f_J; \tilde{A}, \tilde{B}) = \mathcal{M}_2(f_J) \cap (\tilde{A} \times_J \tilde{B}).$$

The following corollaries are immediate consequences (analogue of Proposition 3.14) of Proposition 8.4.

COROLLARY 8.5. *Let $(f_J, \mu_J) = \{(f_s, \mu_s)\}_{s \in J}$ be a generic 1-parameter family of Morse pairs as in Proposition 8.4 and let p be a critical locus of f_J . Then $\mathcal{C}\widetilde{\mathcal{D}}_p(f_J)$ (resp. $\mathcal{C}\widetilde{\mathcal{A}}_p(f_J)$) is a compactification of $\widetilde{\mathcal{D}}_p(f_J)$ (resp. $\widetilde{\mathcal{A}}_p(f_J)$) such that the complement of $\bar{b}^{-1}(\widehat{\Delta}_M)$ in $\mathcal{C}\widetilde{\mathcal{D}}_p(f_J)$ (resp. $\mathcal{C}\widetilde{\mathcal{A}}_p(f_J)$) is a smooth manifold with corners whose codimension k stratum for $k \geq 1$ consists of families of k times broken trajectories and $\partial_{k-1}\overline{\mathcal{D}}_p(f_{\partial J})$ (resp. $\partial_{k-1}\overline{\mathcal{A}}_p(f_{\partial J})$).*

COROLLARY 8.6. *Let $(f_J, \mu_J) = \{(f_s, \mu_s)\}_{s \in J}$ be a generic 1-parameter family of Morse pairs as in Proposition 8.4 and let p, q be critical loci of f_J . Then $\overline{\mathcal{N}}_{pq}(f_J)$ is a compactification of $\mathcal{N}_{pq}(f_J)$ such that the complement of $\bar{b}b^{-1}(\widehat{\Delta}_M)$ in $\overline{\mathcal{N}}_{pq}(f_J)$ is a smooth manifold with corners whose codimension k stratum for $k \geq 1$ consists of families of k times broken trajectories and $\partial_{k-1}\overline{\mathcal{N}}_{pq}(f_{\partial J})$.*

8.3.1. The moduli space $\overline{\mathcal{M}}_2(f_J)$ around a level exchange bifurcation.

We first construct the compactification of $\mathcal{M}_2(f_J)$ around level exchange bifurcations (Lemma 8.2 (1)) and then extend to whole of J . In the construction of $\overline{\mathcal{M}}_2(f)$ (in §3.3), we assumed that the critical values of f are all distinct (Lemma 3.1). However, this is not the case for a 1-parameter family, due to level exchange bifurcations. We consider the space of ‘semi-short’ trajectories that are close to an exchanging pair of critical loci to construct a compact space of trajectories around the level exchange bifurcation. Let $u \in J$ be a level exchange bifurcation and choose a small compact interval $J_u = [u - \varepsilon, u + \varepsilon]$ so that there are no other bifurcations over J_u . We shall prove the following lemma.

LEMMA 8.7. *Let J_u be as above and suppose that μ_{J_u} is such that μ_s is Euclidean near $\Sigma(f_s)$ for each $s \in J_u$. If ε is sufficiently small, then there is a natural compactification $\overline{\mathcal{M}}_2(f_{J_u})$ of $\mathcal{M}_2(f_{J_u})$ such that $\overline{\mathcal{M}}_2(f_{J_u}) - \bar{b}^{-1}(\widehat{\Delta}_M)$ is a smooth manifold with corners whose codimension k stratum for $k \geq 1$ consists of families of k times broken trajectories and $\partial_{k-1}\overline{\mathcal{M}}_2(f_{u \pm \varepsilon})$.*

Let $p = \{p_s\}_{s \in J_u}, q = \{q_s\}_{s \in J_u}$ be the pair of critical loci of $f_{J_u} = \{f_s\}_{s \in J_u}$ that are in a level exchange position. Then there exist smooth functions $\gamma_a, \gamma_b : J_u \rightarrow \mathbb{R}$ such that

- (1) $\gamma_a(s) < \gamma_b(s)$ for all $s \in J_u$,
- (2) $f_s(p_s), f_s(q_s) \in (\gamma_a(s), \gamma_b(s))$ for all $s \in J_u$,
- (3) for each $s \in J_u$, there are no critical points of f_s in $f_s^{-1}[\gamma_a(s), \gamma_b(s)]$ except p_s and q_s .

We put $\tilde{L}_a = \bigcup_{s \in J_u} f_s^{-1}(\gamma_a(s)), \tilde{L}_b = \bigcup_{s \in J_u} f_s^{-1}(\gamma_b(s)), W_{pq}(s) = f_s^{-1}[\gamma_a(s), \gamma_b(s)],$

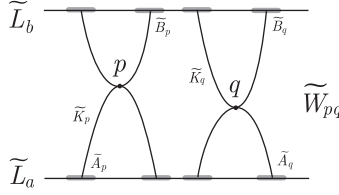

FIG. 8.

$\tilde{W}_{pq} = \bigcup_{s \in J_u} W_{pq}(s)$, all considered as subsets of $J_u \times M_0$. We define

$$\begin{aligned} \overline{\mathcal{M}}_2(f_{J_u}; \tilde{L}_b, \tilde{L}_a) &= \text{Closure}(\mathcal{M}_2(f_{J_u}; \tilde{L}_b, \tilde{L}_a)) \subset \tilde{L}_b \times_{J_u} \tilde{L}_a, \\ \overline{\mathcal{M}}_2(f_{J_u}; \tilde{L}_b, \tilde{W}_{pq}) &= \text{Closure}(\mathcal{M}_2(f_{J_u}; \tilde{L}_b, \tilde{W}_{pq})) \subset \tilde{L}_b \times_{J_u} \tilde{W}_{pq}, \\ \overline{\mathcal{M}}_2(f_{J_u}; \tilde{W}_{pq}, \tilde{L}_a) &= \text{Closure}(\mathcal{M}_2(f_{J_u}; \tilde{W}_{pq}, \tilde{L}_a)) \subset \tilde{W}_{pq} \times_{J_u} \tilde{L}_a, \\ \overline{\mathcal{M}}_2(f_{J_u}; \tilde{W}_{pq}, \tilde{W}_{pq}) &= \text{Closure}(\mathcal{M}_2(f_{J_u}; \tilde{W}_{pq}, \tilde{W}_{pq})) \subset \tilde{W}_{pq} \times_{J_u} \tilde{W}_{pq}. \end{aligned}$$

LEMMA 8.8. *Suppose that $\tilde{\mathcal{D}}_p(f_{J_u}) \cap \tilde{\mathcal{A}}_q(f_{J_u}) = \emptyset$. Then the following hold.*

- (i) $\overline{\mathcal{M}}_2(f_{J_u}; \tilde{L}_b, \tilde{L}_a) - \Delta_J \times \{\infty_M^2\}$ is a submanifold of $\tilde{L}_b \times_{J_u} \tilde{L}_a$ with boundary whose boundary consists of once broken flow sequences and the moduli spaces at endpoints of J_u .
- (ii) $\overline{\mathcal{M}}_2(f_{J_u}; \tilde{L}_b, \tilde{W}_{pq}) - \Delta_J \times \{\infty_M^2\}$ is a submanifold of $\tilde{L}_b \times_{J_u} \tilde{W}_{pq}$ with corners whose boundary consists of once broken flow sequence and of points in $\tilde{L}_b \times_{J_u} \partial \tilde{W}_{pq}$ and the moduli spaces at endpoints of J_u .
- (iii) $\overline{\mathcal{M}}_2(f_{J_u}; \tilde{W}_{pq}, \tilde{L}_a) - \Delta_J \times \{\infty_M^2\}$ is a submanifold of $\tilde{W}_{pq} \times_{J_u} \tilde{L}_a$ with corners whose boundary consists of once broken flow sequences and of points in $\partial \tilde{W}_{pq} \times_{J_u} \tilde{L}_a$ and the moduli spaces at endpoints of J_u .
- (iv) $\overline{\mathcal{M}}_2(f_{J_u}; \tilde{W}_{pq}, \tilde{W}_{pq}) - \hat{\Delta}_{\tilde{W}_{pq}}$ is a submanifold of $\tilde{W}_{pq} \times_{J_u} \tilde{W}_{pq}$ with corners whose boundary consists of once broken flow sequences and of points in $\partial(\tilde{W}_{pq} \times_{J_u} \tilde{W}_{pq}) \cup \hat{\Delta}_{\tilde{W}_{pq}}$ and the moduli spaces at endpoints of J_u .

Proof. First, we prove (i). We assume for simplicity that both p and q are neither maximal nor minimal for all $s \in J_u$. Let $\tilde{K}_p = \bigcup_{s \in J_u} (\mathcal{D}_{p_s}(f_s) \cup \mathcal{A}_{p_s}(f_s)) \cap W_{pq}(s)$ and $\tilde{K}_q = \bigcup_{s \in J_u} (\mathcal{D}_{q_s}(f_s) \cup \mathcal{A}_{q_s}(f_s)) \cap W_{pq}(s)$. See Fig. 8. Take small compact neighborhoods \tilde{B}_p and \tilde{B}_q of $\tilde{K}_p \cap \tilde{L}_b$ and $\tilde{K}_q \cap \tilde{L}_b$ respectively in \tilde{L}_b . Let $\tilde{A}_p \subset \tilde{L}_a$ be the union of $\tilde{K}_p \cap \tilde{L}_a$ and the subset of \tilde{L}_a consisting of points (s, ℓ) such that $\ell = \Phi_{f_s}^t(x)$ for a point $x \in \tilde{B}_p \cap (\{s\} \times M_0)$ and for some $t > 0$. In other words, \tilde{A}_p be the union of $\tilde{K}_p \cap \tilde{L}_a$ and the image of the negative gradient flow from $\tilde{B}_p \cap \tilde{L}_b$. $\tilde{A}_q \subset \tilde{L}_a$ is defined similarly for $\tilde{K}_q \cap \tilde{L}_a$. Let \tilde{C}_p be the subset of \tilde{W}_{pq} consisting of points (s, x) such that either $(s, x) \in \tilde{K}_p$ or such that the integral curve γ_x of $\text{grad}_{\mu_s} f_s$ in $\{s\} \times M_0$ with $\gamma_x(0) = (s, x)$ intersects \tilde{B}_p . $\tilde{C}_q \subset \tilde{W}_{pq}$ is defined similarly for \tilde{K}_q and \tilde{B}_q .

Since $\tilde{K}_p \cap \tilde{K}_q = \emptyset$, we may assume that any trajectory starting from \tilde{B}_p (resp. \tilde{B}_q) are disjoint from trajectories starting from the complement of \tilde{B}_p (resp. \tilde{B}_q). Thus we have

$$\mathcal{M}_2(f_{J_u}; \tilde{B}_p, \tilde{L}_a) = \mathcal{M}_2(f_{J_u}; \tilde{B}_p, \tilde{A}_p), \quad \mathcal{M}_2(f_{J_u}; \tilde{B}_q, \tilde{L}_a) = \mathcal{M}_2(f_{J_u}; \tilde{B}_q, \tilde{A}_q), \quad (8.2)$$

and in particular, the two moduli spaces are disjoint in $\mathcal{M}_2(f_{J_u}; \tilde{L}_b, \tilde{L}_a)$. Since each of \tilde{C}_p and \tilde{C}_q has only one critical locus, the compactifications $\overline{\mathcal{M}}_2(f_{J_u}; \tilde{B}_p, \tilde{A}_p)$, $\overline{\mathcal{M}}_2(f_{J_u}; \tilde{B}_q, \tilde{A}_q)$ can be defined in a similar way as Lemma 3.7 (using parametrized Morse lemma [Ig2, Appendix], assuming μ_s is Euclidean with respect to the local coordinate). They are smooth manifolds with boundary and are closures of $\mathcal{M}_2(f_{J_u}; \tilde{B}_p, \tilde{A}_p)$ and $\mathcal{M}_2(f_{J_u}; \tilde{B}_q, \tilde{A}_q)$ in $\tilde{L}_b \times_{J_u} \tilde{L}_a$. In accordance with (8.2), we define

$$\overline{\mathcal{M}}_2(f_{J_u}; \tilde{B}_p, \tilde{L}_a) = \overline{\mathcal{M}}_2(f_{J_u}; \tilde{B}_p, \tilde{A}_p), \quad \overline{\mathcal{M}}_2(f_{J_u}; \tilde{B}_q, \tilde{L}_a) = \overline{\mathcal{M}}_2(f_{J_u}; \tilde{B}_q, \tilde{A}_q).$$

We construct an extension of $\overline{\mathcal{M}}_2(f_{J_u}; \tilde{B}_p, \tilde{L}_a) \amalg \overline{\mathcal{M}}_2(f_{J_u}; \tilde{B}_q, \tilde{L}_a)$ to $\overline{\mathcal{M}}_2(f_{J_u}; \tilde{L}_b, \tilde{L}_a)$ as follows. Let $\tilde{X} \subset \tilde{L}_b$ be the closure of the complement of $\tilde{B}_p \cup \tilde{B}_q$. Since there is no critical loci except p and q in \tilde{W}_{pq} , the negative gradient flow carries \tilde{X} diffeomorphically onto a compact subset \tilde{Y} of \tilde{L}_a , where \tilde{Y} is the closure of the complement of $\tilde{A}_p \cup \tilde{A}_q$. Hence $\mathcal{M}_2(f_{J_u}; \tilde{X}, \tilde{L}_a) = \mathcal{M}_2(f_{J_u}; \tilde{X}, \tilde{Y}) \approx \tilde{X}$, which is compact. The union $\overline{\mathcal{M}}_2(f_{J_u}; \tilde{B}_p, \tilde{L}_a) \cup \mathcal{M}_2(f_{J_u}; \tilde{X}, \tilde{L}_a) \cup \overline{\mathcal{M}}_2(f_{J_u}; \tilde{B}_q, \tilde{L}_a)$ is a smooth manifold with boundary and is the closure of $\mathcal{M}_2(f_{J_u}; \tilde{L}_b, \tilde{L}_a)$ in $\tilde{L}_b \times_{J_u} \tilde{L}_a$, namely, agrees with $\overline{\mathcal{M}}_2(f_{J_u}; \tilde{L}_b, \tilde{L}_a)$.

For the compactifications $\overline{\mathcal{M}}_2(f_{J_u}; \tilde{L}_b, \tilde{W}_{pq})$, $\overline{\mathcal{M}}_2(f_{J_u}; \tilde{W}_{pq}, \tilde{L}_a)$, $\overline{\mathcal{M}}_2(f_{J_u}; \tilde{W}_{pq}, \tilde{W}_{pq})$ etc. we consider $\overline{\mathcal{M}}_2(f_{J_u}; \tilde{L}_b, \tilde{C}_p)$, $\overline{\mathcal{M}}_2(f_{J_u}; \tilde{C}_p, \tilde{L}_a)$, $\overline{\mathcal{M}}_2(f_{J_u}; \tilde{C}_p, \tilde{C}_p)$ etc. by a similar way as the unparametrized case and extend them as previous paragraph. \square

Proof of Lemma 8.7. We may assume that all the critical loci except p and q are ordered over the interval J_u and according to Lemma 8.2, we may assume that (f_s, μ_s) is Morse–Smale for all $s \in J_s$ if ε is sufficiently small. Thus fiber-product construction similar to Lemma 3.13 can be applied with the moduli spaces in Lemma 8.8 and we will finally get a compactification $\overline{\mathcal{M}}_2(f_{J_u})$ of $\mathcal{M}_2(f_{J_u})$. Then straightforward analogues of Lemmas 3.11, 3.12 and 3.13 show that $\overline{\mathcal{M}}_2(f_{J_u}) - \bar{b}^{-1}(\hat{\Delta}_M)$ is a smooth manifold with corners satisfying the conditions of the lemma. \square

By the same construction at all the level exchange points $u_1, u_2, \dots, u_r \in J_u$, we will obtain a compactification $\overline{\mathcal{M}}_2$ on $\amalg_{j=1}^r J_{u_j}$.

REMARK 8.9. We assumed in Lemma 8.7 that μ_s is Euclidean near critical loci with respect to the local coordinate of parametrized Morse lemma. However, this assumption is not essential because if μ_s is not Euclidean near critical loci, then the flow lines near a critical locus are the images of flow lines in $J_u \times \mathbb{R}^3$ for the standard quadratic form with respect to the Euclidean metric of \mathbb{R}^3 under a fiber-preserving diffeomorphism defined on a neighborhood of $J_u \times \{0\}$. This remark will be taken into account to make sure that the compactification $\overline{\mathcal{M}}_2(f_J)$ in Proposition 8.4 is consistent with that at a birth-death bifurcation.

8.3.2. The moduli space $\overline{\mathcal{M}}_2(f_J)$ on ordered 1-parameter family of Morse pairs. Next, we extend the compactifications of moduli spaces on $\amalg_{j=1}^r J_{u_j}$, given in §8.3.1, over the whole of J . We assume $u_1 < u_2 < \dots < u_r$. Let $I_j \subset J$, $j = 0, 1, 2, \dots, r$ be a sequence of mutually disjoint compact intervals such that

- (1) $\bigcup_{j=0}^r I_j \cup \bigcup_{j=1}^r J_{u_j} = J$,
- (2) $\text{Int } I_j \cap \text{Int } J_{u_j} \neq \emptyset$ if $j > 0$, and $\text{Int } I_j \cap \text{Int } J_{u_{j+1}} \neq \emptyset$ if $j < r$,
- (3) $(\amalg_{j=0}^r I_j) \cap \{u_1, \dots, u_r\} = \emptyset$,

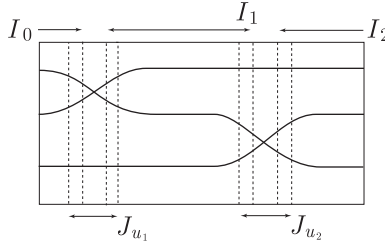

FIG. 9.

(4) $I_j \subset (u_j, u_{j+1})$ if $1 \leq j < r$.

See Fig. 9. We shall construct a compactification $\overline{\mathcal{M}}_2(f_{I_j})$ of $\mathcal{M}_2(f_{I_j})$, which connects $\overline{\mathcal{M}}_2(f_{J_{u_j}})$ and $\overline{\mathcal{M}}_2(f_{J_{u_{j+1}}})$.

LEMMA 8.10. *Let I_j be as above. Then there is a natural compactification $\overline{\mathcal{M}}_2(f_{I_j})$ of $\mathcal{M}_2(f_{I_j})$ such that $\overline{\mathcal{M}}_2(f_{I_j}) - \bar{b}^{-1}(\widehat{\Delta}_M)$ is a smooth manifold with corners whose codimension k stratum for $k \geq 1$ consists of families of k times broken trajectories and $\partial_{k-1}\overline{\mathcal{M}}_2(f_{\partial I_j})$.*

Proof. For each j , the critical values are consistently ordered over I_j , so we can separate critical loci by families of level surfaces of f_s . The compactification of the moduli space of trajectories that lie in a piece between level surfaces can be done as before, by means of the parametrized Morse lemma (e.g., [Ig2, Appendix]) and by the same argument as §3.3.

Recall that in Lemma 3.11, the Morse–Smale condition is required. However, the Morse–Smale condition may not be satisfied for all $s \in I_j$. For example, it fails at an i/i -intersection bifurcation, as we have seen at Lemma 8.2. Instead, we require the parametrized Morse–Smale condition and this suffices for the moduli space to be a smooth submanifold of a fiber bundle over I_j (with fiber $C_2(M)$), though the moduli space may not be a subbundle. Using the parametrized Morse–Smale condition in the fiber-product constructions by straightforward analogues of Lemmas 3.11, 3.12 and 3.13, we may get a compactification $\overline{\mathcal{M}}_2(f_{I_j})$ as desired. \square

Proof of Proposition 8.4. It remains to check that the compactifications obtained on J_{u_j} and I_j in Lemmas 8.7 and 8.10 respectively can be glued smoothly on the overlapping intervals $I_j \cap J_{u_j}$ and $I_j \cap J_{u_{j+1}}$. Let $\tilde{L}_1, \dots, \tilde{L}_{N-2}$ be the loci of level surfaces for $f_{J_{u_j}}$ that are used to define $\overline{\mathcal{M}}_2(f_{u_j})$ and let $\tilde{L}'_1, \dots, \tilde{L}'_{N-1}$ be the loci of level surfaces for f_{I_j} that are used to define $\overline{\mathcal{M}}_2(f_{I_j})$. We may assume without loss of generality that \tilde{L}_i and \tilde{L}'_j are disjoint for any i, j (see Remark 3.5(3)). Let $\overline{\mathcal{M}}_2^\cap(f_{J_{u_j} \cap I_j})$ be the compactification of $\mathcal{M}_2(f_{J_{u_j} \cap I_j})$ defined by using the loci of level surfaces $\tilde{L}_1, \dots, \tilde{L}_{N-2}, \tilde{L}'_1, \dots, \tilde{L}'_{N-1}$. Note that there may be intervals of heights between level surfaces that do not have critical loci. The fiber product construction as Lemma 3.11 with $\overline{\mathcal{M}}_2$ for such an interval does not yield new corners. The forgetful maps give natural embeddings

$$\overline{\mathcal{M}}_2^\cap(f_{J_{u_j} \cap I_j}) \rightarrow \overline{\mathcal{M}}_2(f_{J_{u_j}}), \quad \overline{\mathcal{M}}_2^\cap(f_{J_{u_j} \cap I_j}) \rightarrow \overline{\mathcal{M}}_2(f_{I_j})$$

which gives a strata preserving gluing map between $\overline{\mathcal{M}}_2(f_{J_{u_j}})$ and $\overline{\mathcal{M}}_2(f_{I_j})$. We consider $\overline{\mathcal{M}}_2^\cap(f_{J_{u_j} \cap I_j})$ as a subspace of both $\overline{\mathcal{M}}_2(f_{J_{u_j}})$ and $\overline{\mathcal{M}}_2(f_{I_j})$. Let

$$\overline{\mathcal{M}}_2(f_{J_{u_j} \cup I_j}) = \overline{\mathcal{M}}_2(f_{J_{u_j}}) \cup_{\overline{\mathcal{M}}_2^\cap(f_{J_{u_j} \cap I_j})} \overline{\mathcal{M}}_2(f_{I_j}).$$

For other overlapping intervals, we also glue compactifications similarly. By Lemmas 8.7 and 8.10, the result is as desired. \square

8.4. Gluing of a separated trajectory at birth-death bifurcation. Let $I = [0, 1]$ and let $s_0 \in I$ be a birth-death bifurcation in a generic 1-parameter family $(f_I, \mu_I) = \{(f_s, \mu_s)\}_{s \in I}$. Let p_+ and p_- be the critical loci of f_I that are involved in the birth or death bifurcation s_0 , such that $i(p_-) = i(p_+) + 1$. The space $\mathcal{N}_{p_- p_+}(f_I) \subset [0, 1] \times C_2(M)$ can be considered as the moduli space of ‘separated’ trajectories. In this subsection we shall see that $\mathcal{N}_{p_- p_+}(f_I)$ and $\mathcal{M}_2(f_I)$ are smoothly glued together at the time $s = s_0$. Here, we shall only study a death point since a birth point is symmetric.

Let $s_0 \in [0, 1]$ be a death parameter in a generic 1-parameter family and let $J_{s_0} \subset [0, 1]$ be a small open interval including s_0 . Let $v \in M_0$ be the death point at s_0 . By the normal form lemma for an unfolding of a birth-death singularity (e.g., [Ig2, Appendix], [Ce]), there is a local coordinate on a neighborhood M_v of v in $J_{s_0} \times M$ on which f_s agrees with

$$h_u(x) = c(u) + \frac{x_1^3}{3} + ux_1 - \frac{x_2^2}{2} - \dots - \frac{x_i^2}{2} + \frac{x_{i+1}^2}{2} + \dots + \frac{x_d^2}{2}, \quad u \in \mathbb{R},$$

where u is a reparametrization of s such that $s = s_0$ corresponds to $u = 0$, and $c(u)$ is a smooth function of u , and one can choose a metric on $J_{s_0} \times M_0$ whose restriction on M_v agrees with the restriction of the standard metric on $\mathbb{R} \times \mathbb{R}^d$. The negative gradient of h_u with respect to the standard metric is

$$-\text{grad } h_u = (-x_1^2 - u, x_2, \dots, x_i, -x_{i+1}, \dots, -x_d).$$

On $u > 0$, there are no critical points of h_u . At $u = 0$, there is only one critical point of h_u at the origin, and on $u < 0$, there are exactly two critical points $p_\pm = (\pm\sqrt{|u|}, 0, \dots, 0)$ of h_u . From now on we shall describe how a pair of trajectories going from/to critical points of h_u on $u < 0$ are glued together into a single trajectory on $u > 0$. It gives a gluing of a moduli space of a separated edge and that of a compact edge.

8.4.1. Gradient trajectories of h_u in $u > 0$. Here, we may assume for simplicity that $c(u) = 0$ for $u \in \mathbb{R}$, without changing the gradients. The integral curve $\gamma : \mathbb{R} \rightarrow \mathbb{R}^d$, $\gamma(t) = (\gamma_1(t), \dots, \gamma_d(t))$ of $-\text{grad } h_u$ is determined by the system of differential equations:

$$\begin{aligned} \dot{\gamma}_1(t) &= -\gamma_1(t)^2 - u, \quad \dot{\gamma}_2(t) = \gamma_2(t), \quad \dots, \quad \dot{\gamma}_i(t) = \gamma_i(t), \\ \dot{\gamma}_{i+1}(t) &= -\gamma_{i+1}(t), \quad \dots, \quad \dot{\gamma}_d(t) = -\gamma_d(t), \end{aligned} \tag{8.3}$$

for each given initial point $(\gamma_1(0), \dots, \gamma_d(0))$. In $u > 0$, the solution of (8.3) is given explicitly by

$$\begin{aligned} \gamma_1(t) &= \frac{\sqrt{u} \gamma_1(0) - u \tan \sqrt{u} t}{\sqrt{u} + \gamma_1(0) \tan \sqrt{u} t}, \quad \gamma_2(t) = \gamma_2(0)e^t, \quad \dots, \quad \gamma_i(t) = \gamma_i(0)e^t, \\ \gamma_{i+1}(t) &= \gamma_{i+1}(0)e^{-t}, \quad \dots, \quad \gamma_d(t) = \gamma_d(0)e^{-t}. \end{aligned} \tag{8.4}$$

For a small number $\varepsilon > 0$, let L_ε and $L_{-\varepsilon}$ be the subsets of \mathbb{R}^d given by

$$L_\varepsilon = \{(\varepsilon, x_2, \dots, x_d) \in \mathbb{R}^d; x_2, \dots, x_d \in \mathbb{R}\},$$

$$L_{-\varepsilon} = \{(-\varepsilon, x_2, \dots, x_d) \in \mathbb{R}^d; x_2, \dots, x_d \in \mathbb{R}\}.$$

These are approximations of level surfaces at the levels $\pm\varepsilon$ in a neighborhood of the origin. Since $(-\text{grad } h_u)_{(0, x_2, \dots, x_d)} = (-u, x_2, \dots, x_i, -x_{i+1}, \dots, -x_d)$, one may see that any trajectory of h_u in $u > 0$ and in M_v intersects both L_ε and $L_{-\varepsilon}$. Conversely, for any point a of $L_\varepsilon \cap M_v$ (resp. $L_{-\varepsilon} \cap M_v$), there exists a unique (shift equivalence class of) gradient trajectory of h_u which intersects L_ε (resp. $L_{-\varepsilon}$) at a . So there is a one-to-one correspondence between a point on L_ε or $L_{-\varepsilon}$ and a gradient trajectory of h_u that is close to the origin. We identify a gradient trajectory with the pair of its intersection points with $L_{-\varepsilon} \amalg L_\varepsilon$.

Now suppose that an integral curve $\gamma(t)$ of $-\text{grad } h_u$ starts at a point of L_ε . We shall describe the point $\text{Im } \gamma \cap L_{-\varepsilon}$. If $\gamma(t_{-\varepsilon}) \in L_{-\varepsilon}$ at $t_{-\varepsilon} > 0$, then by (8.3),

$$t_{-\varepsilon} = - \int_\varepsilon^{-\varepsilon} \frac{dx}{x^2 + u} = \frac{2}{\sqrt{u}} \text{Tan}^{-1} \frac{\varepsilon}{\sqrt{u}}$$

for $0 < u < \varepsilon^2$. We put $\tau_\varepsilon(u) = \frac{2}{\sqrt{u}} \text{Tan}^{-1} \frac{\varepsilon}{\sqrt{u}}$. The point $\gamma(t_{-\varepsilon})$ can be expressed by using $\tau_\varepsilon(u)$ as follows.

$$\gamma(t_{-\varepsilon}) = (-\varepsilon, \gamma_2(0)e^{\tau_\varepsilon(u)}, \dots, \gamma_i(0)e^{\tau_\varepsilon(u)}, \gamma_{i+1}(0)e^{-\tau_\varepsilon(u)}, \dots, \gamma_d(0)e^{-\tau_\varepsilon(u)}).$$

If we put $\varepsilon_2 = \gamma_2(0)e^{\tau_\varepsilon(u)}, \dots, \varepsilon_i = \gamma_i(0)e^{\tau_\varepsilon(u)}, \varepsilon_{i+1} = \gamma_{i+1}(0), \dots, \varepsilon_d = \gamma_d(0)$, then the integral curve starting at the point

$$(\varepsilon, \varepsilon_2 e^{-\tau_\varepsilon(u)}, \dots, \varepsilon_i e^{-\tau_\varepsilon(u)}, \varepsilon_{i+1}, \dots, \varepsilon_d) \in L_\varepsilon \tag{8.5}$$

intersects $L_{-\varepsilon}$ at the point

$$(-\varepsilon, \varepsilon_2, \dots, \varepsilon_i, \varepsilon_{i+1} e^{-\tau_\varepsilon(u)}, \dots, \varepsilon_d e^{-\tau_\varepsilon(u)}) \in L_{-\varepsilon}. \tag{8.6}$$

This observation motivates the gluing formula below.

8.4.2. Gradient trajectories of h_u going from/to critical points in $u \leq 0$.

In $u < 0$, the ascending and descending manifolds of h_u are described as follows.

$$\begin{aligned} \mathcal{A}_{p_+}(h_u) &= \{(x_1, \dots, x_d) \in \mathbb{R}^d; x_2 = \dots = x_i = 0, x_1 \geq -\sqrt{|u|}\}, \\ \mathcal{D}_{p_+}(h_u) &= \{(x_1, \dots, x_d) \in \mathbb{R}^d; x_{i+1} = \dots = x_d = 0, x_1 = \sqrt{|u|}\}, \\ \mathcal{A}_{p_-}(h_u) &= \{(x_1, \dots, x_d) \in \mathbb{R}^d; x_2 = \dots = x_i = 0, x_1 = -\sqrt{|u|}\}, \\ \mathcal{D}_{p_-}(h_u) &= \{(x_1, \dots, x_d) \in \mathbb{R}^d; x_{i+1} = \dots = x_d = 0, x_1 \leq \sqrt{|u|}\}. \end{aligned}$$

See Fig. 10. Hence

$$\begin{aligned} L_\varepsilon \cap \mathcal{A}_{p_+}(h_u) &= \{(\varepsilon, 0, \dots, 0, \varepsilon_{i+1}, \dots, \varepsilon_d) \in \mathbb{R}^d; \varepsilon_{i+1}, \dots, \varepsilon_d \in \mathbb{R}\}, \\ L_{-\varepsilon} \cap \mathcal{D}_{p_-}(h_u) &= \{(-\varepsilon, \varepsilon_2, \dots, \varepsilon_i, 0, \dots, 0) \in \mathbb{R}^d; \varepsilon_2, \dots, \varepsilon_i \in \mathbb{R}\}. \end{aligned} \tag{8.7}$$

One may check that this also holds for $u = 0$, in which case $p_+ = p_- = v$.

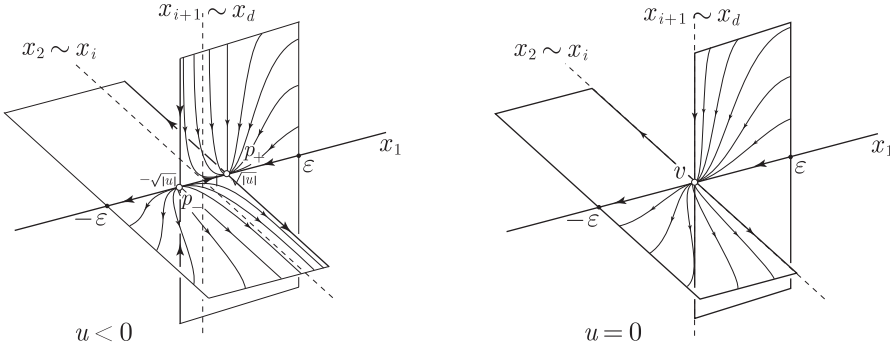

FIG. 10.

8.4.3. Gluing formula at $u = 0$. We define an injective map

$$\varphi : (-\varepsilon^2, \varepsilon^2) \times \mathbb{R}^{d-1} \rightarrow (-\varepsilon^2, \varepsilon^2) \times \mathbb{R}^{d-1} \times \mathbb{R}^{d-1} \quad \text{by}$$

$$\varphi(u; \varepsilon_2, \dots, \varepsilon_d) = \begin{cases} u \times (\varepsilon_2 e^{-\tau_\varepsilon(u)}, \dots, \varepsilon_i e^{-\tau_\varepsilon(u)}, \varepsilon_{i+1}, \dots, \varepsilon_d) \\ \quad \times (\varepsilon_2, \dots, \varepsilon_i, \varepsilon_{i+1} e^{-\tau_\varepsilon(u)}, \dots, \varepsilon_d e^{-\tau_\varepsilon(u)}), & \text{if } u > 0 \\ u \times (0, \dots, 0, \varepsilon_{i+1}, \dots, \varepsilon_d) \times (\varepsilon_2, \dots, \varepsilon_i, 0, \dots, 0), & \text{if } u \leq 0 \end{cases}$$

For any u we may identify the space of gradient trajectories of h_u or pairs of gradient trajectories of h_u intersecting both L_ε and $L_{-\varepsilon}$, with a subspace of $L_\varepsilon \times L_{-\varepsilon}$ through φ . By (8.7), the non-positive part $\varphi((-\varepsilon^2, 0] \times \mathbb{R}^{d-1})$ is the space of pairs $(\gamma_{p_+}(t), \gamma_{p_-}(t))$ of integral curves of $-\text{grad } h_u$ satisfying the conditions

$$\lim_{t \rightarrow \infty} \gamma_{p_+}(t) = p_+, \quad \gamma_{p_+}(0) \in L_\varepsilon, \quad \lim_{t \rightarrow -\infty} \gamma_{p_-}(t) = p_-, \quad \gamma_{p_-}(0) \in L_{-\varepsilon}. \quad (8.8)$$

On the other hand, by (8.5) and (8.6), the positive part $\varphi((0, \varepsilon^2) \times \mathbb{R}^{d-1})$ is the space of negative gradient trajectories of h_u , $u > 0$, near the origin. In other words,

$$\begin{aligned} \varphi((-\varepsilon^2, 0] \times \mathbb{R}^{d-1}) &= \mathcal{N}_{p_- p_+}(\{h_u\}_{u \in (-\varepsilon^2, 0]}) \cap (-\varepsilon^2, 0] \times (L_\varepsilon \times L_{-\varepsilon}), \\ \varphi((0, \varepsilon^2) \times \mathbb{R}^{d-1}) &= \mathcal{M}_2(\{h_u\}_{u \in (0, \varepsilon^2)}) \cap (0, \varepsilon^2) \times (L_\varepsilon \times L_{-\varepsilon}). \end{aligned}$$

The following proposition gives a gluing of moduli spaces of short trajectories.

PROPOSITION 8.11. *The map φ is smooth and is an embedding. Hence $\text{Im } \varphi$ is a smooth submanifold of $(-\varepsilon^2, \varepsilon^2) \times (L_\varepsilon \times L_{-\varepsilon})$ without boundary.*

Proof. Let $\sigma_\varepsilon : (-\varepsilon^2, \varepsilon^2) \rightarrow \mathbb{R}$ be the function defined by

$$\sigma_\varepsilon(u) = \begin{cases} e^{-\tau_\varepsilon(u)} & \text{if } u > 0 \\ 0 & \text{if } u \leq 0 \end{cases}$$

The map φ can be rewritten as

$$\begin{aligned} \varphi(u; \varepsilon_2, \dots, \varepsilon_d) &= u \times (\varepsilon_2 \sigma_\varepsilon(u), \dots, \varepsilon_i \sigma_\varepsilon(u), \varepsilon_{i+1}, \dots, \varepsilon_d) \\ &\quad \times (\varepsilon_2, \dots, \varepsilon_i, \varepsilon_{i+1} \sigma_\varepsilon(u), \dots, \varepsilon_d \sigma_\varepsilon(u)). \end{aligned}$$

One may see that σ_ε is C^∞ differentiable (see [Wa1] for the proof). Hence φ is C^∞ differentiable. That the Jacobian matrix has full rank is obvious from the definition of φ on $u \leq 0$. Hence φ is an embedding. \square

8.5. Compactification of $\mathcal{M}_\Gamma(\vec{f}_J)$ in generic 1-parameter family.

8.5.1. Compactification of the moduli space $\mathcal{M}_\Gamma(\vec{f}_J)$ in 1-parameter family of Morse pairs. By using the compactification $\overline{\mathcal{M}}_2(f_J)$ and $\overline{\mathcal{N}}_{pq}(f_J)$ given in §8.3, one can also define the compactification $\overline{\mathcal{M}}_\Gamma(f_J)$ of $\mathcal{M}_\Gamma(f_J)$ in a similar way as §4.3. We have the following proposition.

PROPOSITION 8.12. *Suppose $d = 3$, $\Gamma \in \mathcal{G}_{2k,3k}^0(\vec{C})$ and that Γ does not have a bivalent vertex. After a small perturbation of the family $(f_J, \mu_J) = \{(f_s, \mu_s)\}_{s \in J}$ of Morse pairs fixing the endpoints, we may arrange that $\overline{\mathcal{M}}_\Gamma(\vec{f}_J)$ is a compact smooth 1-manifold with boundary. The boundary consists of flow graphs with a once broken trajectory or with a subgraph collapsed to a point.*

The proof of Proposition 8.12 is analogous to Proposition 2.5 (proof in §4.3). Namely, we construct a singular compactification $\overline{\mathcal{M}}_\Gamma^\times(\vec{f}_J)$ of $\mathcal{M}_\Gamma(\vec{f}_J)$ in $\prod_{j=1}^{3k} \tilde{Q}_j$, where \tilde{Q}_j is either $\overline{\mathcal{M}}_2(\vec{f}_J)$ or $\overline{\mathcal{N}}_{pq}(\vec{f}_J)$. Then a sequence of blowing-ups along the diagonals yields $\overline{\mathcal{M}}_\Gamma(\vec{f}_J)$.

8.5.2. Gluing of $\overline{\mathcal{M}}_\Gamma(\vec{f}_J)$ at birth-death point. Let $s_0 \in [0, 1]$ be a death parameter in a generic 1-parameter family $\{(f_s, \mu_s)\}_{s \in [0,1]}$. For sufficiently small number $\varepsilon' > 0$, let (p_1, q_1) be the pair of critical points of $f_{s_0-\varepsilon'}$, such that $i(p_1) = i(q_1) + 1$ and such that they are eliminated on $s > s_0$ after passing through the death point v . Then we have the following proposition.

PROPOSITION 8.13. *Suppose $d = 3$ and that s_0 is as above. Let $\Gamma(p_1, q_1)_1 \in \mathcal{G}_{2k,3k}(\vec{C}^{(s_0-\varepsilon')})$ be a graph with no bivalent vertices and let $\Gamma(\emptyset, \emptyset)_1$ be the graph obtained from $\Gamma(p_1, q_1)_1$ by replacing the separated edge $\beta(1)$ with a compact edge. If ε' is sufficiently small, then the embedding φ of Proposition 8.11 induces a smooth compact 1-dimensional cobordism between*

$$\overline{\mathcal{M}}_{\Gamma(\emptyset, \emptyset)_1}(\vec{f}_{s_0+\varepsilon'}) \text{ and } \overline{\mathcal{M}}_{\Gamma(p_1, q_1)_1}(\vec{f}_{s_0-\varepsilon'}) \amalg \overline{\mathcal{M}}_{\Gamma(\emptyset, \emptyset)_1}(\vec{f}_{s_0-\varepsilon'}).$$

Proof. If $d = 3$, then by Proposition 2.4, $\dim \overline{\mathcal{M}}_\Gamma(\vec{f}_s) = 0$ for $\Gamma \in \mathcal{G}_{2k,3k}^0(\vec{C}^{(s)})$ and for generic parameter s . If ε' is sufficiently small, there exists $\varepsilon > 0$ such that the pair of half trajectories that converge to p_1 and q_1 at $s = s_0 - \varepsilon'$ intersects $M_v \cap L_{-\varepsilon}$ and $M_v \cap L_\varepsilon$ respectively, since the broken trajectory at $s = s_0$ satisfies this property. Thus we may use $\text{Im } \varphi$ of Proposition 8.11 to construct the desired cobordism by a fiber-product construction similar to Lemma 3.11, 3.12 and 3.13. \square

9. (Co)orientation of the moduli spaces in 1-parameter family.

9.1. Convention for (co)orientations in 1-parameter family. Let $J = [s_0, s_1]$ and let (f_J, μ_J) be a 1-parameter family of Morse pairs. In this section, we assume without loss of generality that $f_s = f_{s_0}$ for all $s \in [s_0, s_0 + \varepsilon]$ ($\varepsilon > 0$ small) and $f_s = f_{s_1}$ for all $s \in [s_1 - \varepsilon, s_1]$. We orient $J \times M$ and $J \times \overline{C}_{2k}(M)$ by

$$o(J \times M)_{(s,x)} = ds \wedge o(M)_x, \quad o(J \times M^{2k})_{(s,\vec{x})} = ds \wedge o(M^{2k})_{\vec{x}}.$$

We define the coorientations $o_{J \times M}^*(\tilde{\mathcal{D}}_p(f_J))$ and $o_{J \times M}^*(\tilde{\mathcal{A}}_p(f_J))$ so that their restrictions to $\{s_0\} \times M$ are equivalent to $o_{\{s_0\} \times M}^*(\mathcal{D}_p(f_{s_0}))$ and $o_{\{s_0\} \times M}^*(\mathcal{A}_p(f_{s_0}))$ respectively. Similarly, we define the coorientations $o_{J \times M^2}^*(\mathcal{M}_2(f_J))$ and $o_{J \times M^2}^*(\mathcal{N}_{pq}(f_J))$

so that their restrictions to $\{s_0\} \times M^2$ are equivalent to $o_{\{s_0\} \times M^2}^*(\mathcal{M}_2(f_{s_0}))$ and $o_{\{s_0\} \times M^2}^*(\mathcal{N}_{pq}(f_{s_0}))$ respectively. Thus

$$o_{J \times M^2}^*(\mathcal{N}_{pq}(f_J)) = o_{J \times M}^*(\widetilde{\mathcal{A}}_q(f_J)) \wedge o_{J \times M}^*(\widetilde{\mathcal{D}}_p(f_J)).$$

For $\Gamma \in \mathcal{G}_{2k,3k}^0(\vec{C})$, we define the coorientation $o_{J \times M^{2k}}^*(\mathcal{M}_\Gamma(\vec{f}_J))$ so that its restriction to $\{s_0\} \times M^{2k}$ is equivalent to $o_{\{s_0\} \times M^{2k}}^*(\mathcal{M}_\Gamma(\vec{f}_{s_0}))$.

If p and r are critical loci of f_J such that $i(p) = i(r)$, then the moduli space

$$\mathcal{M}'(f_J; p, r) = (\widetilde{\mathcal{D}}_p(f_J) \pitchfork \widetilde{\mathcal{A}}_r(f_J)) \pitchfork \widetilde{L},$$

where \widetilde{L} is the level surface locus that lies just below p , is a compact 0-manifold in $\text{Int } J \times M$ for a generic family f_J . At each point $b \in \mathcal{M}'(f_J; p, r)$, the wedge product $o_{J \times M}^*(\widetilde{\mathcal{D}}_p(f_J))_b \wedge o_{J \times M}^*(\widetilde{\mathcal{A}}_r(f_J))_b \in \bigwedge^d T_b^* \widetilde{L} \subset \bigwedge^d T_b^*(J \times M)$ defines a coorientation of the flow line passing through b (see Appendix B (B.4)). We define the sign $\varepsilon_{f_J}(p, r)_b = \pm 1$ so that the following equivalence holds.

$$o_{J \times M}^*(\widetilde{\mathcal{D}}_p(f_J))_b \wedge o_{J \times M}^*(\widetilde{\mathcal{A}}_r(f_J))_b \sim \varepsilon_{f_J}(p, r)_b \iota(-\text{grad } f_{s_0}) o(J \times M)_b.$$

9.2. (Co)orientations induced on the boundaries of $\widetilde{\mathcal{D}}$, $\widetilde{\mathcal{A}}$ at i/i -intersection. Suppose that an i/i -intersection occurs at $s = u$. For a small number $\varepsilon > 0$, let $J = [u - \varepsilon, u + \varepsilon]$. For a parametrized Morse–Smale pair (f_J, μ_J) and its critical loci p, q , we shall describe the induced (co)orientations of the faces $\mathcal{F}_r \mathcal{C} \widetilde{\mathcal{D}}_p(f_J)$ (resp. $\mathcal{F}_r \mathcal{C} \widetilde{\mathcal{A}}_q(f_J)$) of $\partial_1 \mathcal{C} \widetilde{\mathcal{D}}_p(f_J)$ (resp. $\partial_1 \mathcal{C} \widetilde{\mathcal{A}}_q(f_J)$) of flow lines broken at a critical locus r , which are induced from the (co)orientation of $\mathcal{C} \widetilde{\mathcal{D}}_p(f_J)$ (resp. $\mathcal{C} \widetilde{\mathcal{A}}_q(f_J)$).

We consider coorientations of the faces $\mathcal{F}_r \mathcal{C} \widetilde{\mathcal{D}}_p(f_J)$ and $\mathcal{F}_r \mathcal{C} \widetilde{\mathcal{A}}_q(f_J)$ as follows. Let $\bar{b} : \mathcal{C} \widetilde{\mathcal{D}}_p(f_J) \rightarrow J \times M$ be the map that assigns to each (possibly broken) flow sequence the terminal endpoint. If $i(p) - i(r) = 0$ and if a is a point of $J \times M$ that is the image of \bar{b} from a once broken flow sequence \hat{a} in $\partial_1 \mathcal{C} \widetilde{\mathcal{D}}_p(f_J)$ broken at a critical locus r , then by Corollary 8.5 there is an open neighborhood N_a of a in $J \times M$ such that $\bar{b}^{-1}(N_a)$ is a disjoint union of finitely many half-disks whose set of components naturally corresponds to the finite set $\mathcal{M}'(f_J; p, r)$. Let \widehat{N}_a be the component of $\bar{b}^{-1}(N_a)$ on which \hat{a} lies. The restriction of \bar{b} to \widehat{N}_a is an embedding and hence the coorientation $o_{J \times M}^*(\partial_1 \mathcal{C} \widetilde{\mathcal{D}}_p(f_J))_a$ makes sense by identifying \widehat{N}_a with $\bar{b}(\widehat{N}_a)$. The same is also true for $\partial_1 \mathcal{C} \widetilde{\mathcal{A}}_q(f_J)$ at a once broken flow sequence broken at r such that $i(r) - i(q) = 0$.

Note that $\text{Int } \bar{b}(\widehat{N}_a)$ is an open subset of $\widetilde{\mathcal{D}}_p(f_J)$ and its closure in N_a is $\bar{b}(\widehat{N}_a)$. Hence the (co)orientation of $\widetilde{\mathcal{D}}_p(f_J)$ induces a (co)orientation of the boundary $\partial \bar{b}(\widehat{N}_a)$ at a . We define $o_{J \times M}^*(\partial_1 \mathcal{C} \widetilde{\mathcal{D}}_p(f_J))_a$ to be the one induced in this way. We also define $o_{J \times M}^*(\partial_1 \mathcal{C} \widetilde{\mathcal{A}}_q(f_J))_a$ similarly.

LEMMA 9.1. *Under the assumption above, let p, r be critical loci of f_J such that $f_J(p) > f_J(r)$ and $i(p) - i(r) = 0$. Let N_a and $a \in \bar{b}(\widehat{N}_a)$ be as above. Let b be a point of $\mathcal{M}'(f_J; p, r)$ such that \widehat{N}_a corresponds to b . Then the following identity in $\bigwedge^\bullet T_a^*(J \times M)$ holds.*

$$o_{J \times M}^*(\partial_1 \mathcal{C} \widetilde{\mathcal{D}}_p(f_J))_a = (-1)^{i(r)} \varepsilon_{f_J}(p, r)_b ds \wedge o_{J \times M}^*(\widetilde{\mathcal{D}}_r(f_J))_a.$$

Proof. Let $i = i(r)$. By assumptions $f_J(p) > f_J(r)$ and $i(p) - i(r) = 0$, the index of r is in $1 \leq i(r) \leq d - 1$. It suffices to check the assertion for one broken flow line. By parametrized Morse Lemma there is a local coordinate (x_1, \dots, x_d) around r on which f_s agrees with $f_s(r) - \frac{x_1^2}{2} - \dots - \frac{x_i^2}{2} + \frac{x_{i+1}^2}{2} + \dots + \frac{x_d^2}{2}$. In this coordinate, $\tilde{\mathcal{D}}_r(f_J)$ agrees with $\{(s, x_1, \dots, x_d) \in J \times \mathbb{R}^d; x_{i+1} = \dots = x_d = 0\}$ and $\tilde{\mathcal{A}}_r(f_J)$ agrees with $\{(s, x_1, \dots, x_d) \in J \times \mathbb{R}^d; x_1 = \dots = x_i = 0\}$. By convention of §9.1, we may put

$$o(\tilde{\mathcal{D}}_r(f_J)) = \beta ds dx_1 \cdots dx_i, \quad o(\mathcal{D}_r(f_s)) = \beta dx_1 \cdots dx_i \quad (\beta = \pm 1)$$

By the transversality theorem, we may assume that the intersection of $\tilde{\mathcal{D}}_p(f_J)$ with the plane $\{(s, x_1, \dots, x_d) \in J \times \mathbb{R}^d; x_d = 1\}$ agrees with the set

$$\{(s, (s - u)\lambda, a_2, \dots, a_i, 0, \dots, 0, 1); s \in J, a_2, \dots, a_i \in \mathbb{R}\}$$

for some $\lambda \neq 0$. Hence $\tilde{\mathcal{D}}_p(f_J)$ agrees locally with the set of points

$$(s, (s - u)\lambda e^t, a_2 e^t, \dots, a_i e^t, 0, \dots, 0, e^{-t}), \quad t \in \mathbb{R}.$$

By putting $a'_1 = (s - u)\lambda e^t$, $a'_2 = a_2 e^t, \dots, a'_i = a_i e^t$, $s' = (s - u)/a'_1$, one may see that the closure of this agrees with the set of points

$$(s' a'_1 + u, a'_1, a'_2, \dots, a'_i, 0, \dots, 0, s' \lambda), \quad a'_1, a'_2, \dots, a'_i \in \mathbb{R}, s' \in [-\varepsilon/a'_1, \varepsilon/a'_1],$$

whose first order approximation is $(u, a'_1, a'_2, \dots, a'_i, 0, \dots, 0, s' \lambda)$. Hence for $a = (u, 0, \dots, 0) \in J \times \mathbb{R}^d$, we may put

$$o(\bar{b}(\widehat{N}_{\bar{a}}))_a = \alpha \lambda dx_1 dx_2 \cdots dx_i dx_d \quad (\alpha = \pm 1).$$

Then we have

$$o(\partial \bar{b}(\widehat{N}_{\bar{a}}))_a = \iota \left(-\frac{\partial}{\partial x_d} \right) \alpha \lambda dx_1 \cdots dx_i dx_d = (-1)^{i+1} \alpha \lambda dx_1 \cdots dx_i = (-1)^{i+1} \alpha \beta \lambda o(\mathcal{D}_r(f_u))_a.$$

On the other hand, by assumption we have

$$\begin{aligned} o_{J \times M}^*(\tilde{\mathcal{D}}_p(f_J))_b &= (-1)^d \alpha \lambda ds dx_{i+1} \cdots dx_{d-1}, \\ o_{J \times M}^*(\tilde{\mathcal{A}}_r(f_J))_b &= (-1)^{i(d-i)} \beta dx_1 \cdots dx_i \end{aligned}$$

for $b = (0, \dots, 0, 1)$. Hence

$$\begin{aligned} o_{J \times M}^*(\tilde{\mathcal{D}}_p(f_J))_b \wedge o_{J \times M}^*(\tilde{\mathcal{A}}_r(f_J))_b &= (-1)^{i+d} \alpha \beta \lambda ds dx_1 \cdots dx_{d-1} \\ &= (-1)^{i+1} \alpha \beta \lambda \iota \left(-\frac{\partial}{\partial x_d} \right) o(J \times M) \end{aligned}$$

and $\varepsilon_{f_J}(p, r)_b = (-1)^{i+1} \alpha \beta \lambda$. This together with the equality above, we obtain

$$\begin{aligned} o(\partial_1 \mathcal{E} \tilde{\mathcal{D}}_p(f_J))_a &= o(\partial \bar{b}(\widehat{N}_{\bar{a}}))_a = \varepsilon_{f_J}(p, r)_b o(\mathcal{D}_r(f_u))_a, \\ o_{J \times M}^*(\partial_1 \mathcal{E} \tilde{\mathcal{D}}_p(f_J))_a &= \varepsilon_{f_J}(p, r)_b o_{J \times M}^*(\mathcal{D}_r(f_u))_a = \varepsilon_{f_J}(p, r)_b (-1)^i \beta ds dx_{i+1} \cdots dx_d \\ &= (-1)^i \varepsilon_{f_J}(p, r)_b ds \wedge o_{J \times M}^*(\tilde{\mathcal{D}}_r(f_J))_a. \end{aligned}$$

□

LEMMA 9.2. *Under the assumption above, let q, r be critical points of f such that $f_J(q) < f_J(r)$ and $i(r) - i(q) = 0$. Let N_a and $a \in \bar{b}(\widehat{N}_a)$ be as above. Let b be a point of $\mathcal{M}'(f; r, q)$ such that \widehat{N}_a corresponds to b . Then the following identity in $\bigwedge^\bullet T_a^*(J \times M)$ holds.*

$$o_{J \times M}^*(\partial_1 \mathcal{C} \widetilde{\mathcal{A}}_q(f_J))_a = (-1)^{i(r)+d+1} \varepsilon_{f_J}(r, q)_b ds \wedge o_{J \times M}^*(\widetilde{\mathcal{A}}_r(f_J))_a.$$

The proof of Lemma 9.2 is similar to that of Lemma 9.1. See [Wa1] for the proof.

9.3. Change of combinatorial propagator at i/i -intersection. Suppose that an i/i -intersection between critical points (loci) p and q occurs at $s = u \in I$ in a generic 1-parameter family (f_I, μ_I) . For a small number $\varepsilon > 0$, we may identify the underlying \mathbb{Z} -modules of $C_*^{(u-\varepsilon)}$ and $C_*^{(u+\varepsilon)}$ and moreover we identify critical points and critical loci as bases of \mathbb{Z} -modules. We put $J = [u - \varepsilon, u + \varepsilon]$, $C_*^{(J)} = C_*^{(u-\varepsilon)} = C_*^{(u+\varepsilon)}$ and $P_*^{(J)} = P_*^{(u-\varepsilon)} = P_*^{(u+\varepsilon)}$. Let $h : C_*^{(J)} \rightarrow C_*^{(J)}$ be the homomorphism of homogeneous degree 0, defined for each critical point (locus) $x \in P_i^{(J)}$ by

$$h(x) = \sum_{y \in P_i^{(J)}} \# \mathcal{M}'(f_J; x, y) \cdot y, \quad \# \mathcal{M}'(f_J; x, y) = \sum_{b \in \mathcal{M}'(f_J; x, y)} \varepsilon_{f_J}(x, y)_b.$$

Since the moduli space $\mathcal{M}'(f_J; x, y)$ corresponds to an i/i -intersection, h is non-zero only if $x = p$. Then for $b \in \mathcal{M}'(f_J; p, q)$, we have $h(p) = \varepsilon_{f_J}(p, q)_b \cdot q$. We denote the boundary operators of $C_*^{(u-\varepsilon)}$ and $C_*^{(u+\varepsilon)}$ by ∂ and ∂' respectively. The following lemma describes the bifurcation of Morse complex at the i/i -intersection and is stated in several papers (e.g. [Lau, Hu] and [Fuk2, Lemma 5.1]).

LEMMA 9.3. *Under the assumption above, we have*

$$\partial - \partial' = \partial h - h \partial' = \partial' h - h \partial,$$

or equivalently, $(1 - h) \circ \partial' = \partial \circ (1 - h)$ and $(1 + h) \circ \partial = \partial' \circ (1 + h)$, or $1 + h : C_^{(u-\varepsilon)} \rightarrow C_*^{(u+\varepsilon)}$ is a chain map.*

Proof. Let p, q be critical loci of f_J such that $i(p) - i(q) = 0$. We check the identities

$$\partial' - \partial + \partial h - h \partial' = 0, \quad \partial' - \partial + \partial' h - h \partial = 0.$$

We consider the boundary of the moduli spaces $\mathcal{M}'(f_J; p, r)$ and $\mathcal{M}'(f_J; r', q)$ compactified using the compactifications $\mathcal{C} \widetilde{\mathcal{D}}$ and $\mathcal{C} \widetilde{\mathcal{A}}$. The contribution of ∂J is $\partial' - \partial$. The other contributions come from the broken flow lines of the i/i -intersection at $s = u$. For a critical locus r with $i(r) = i(p) - 1$, the broken flow line from p to r broken at q contributes as $-\varepsilon_{f_J}(p, q)_b \varepsilon_{f_u}(q, r)_a$. Indeed, the coorientation of the boundary of $\mathcal{M}'(f_J; p, r)$ is

$$\begin{aligned} & (-1)^{i(r)} o_{J \times M}^*(\partial \mathcal{C} \widetilde{\mathcal{D}}_p(f_J))_a \wedge o_{J \times M}^*(\widetilde{\mathcal{A}}_r(f_J))_a \\ &= (-1)^{i(r)} (-1)^{i(q)} \varepsilon_{f_J}(p, q)_b ds \wedge o_{J \times M}^*(\widetilde{\mathcal{D}}_q(f_J))_a \wedge o_{J \times M}^*(\widetilde{\mathcal{A}}_r(f_J))_a \\ &= (-1)^{i(r)+i(q)} \varepsilon_{f_J}(p, q)_b ds \wedge \varepsilon_{f_u}(q, r)_a \iota(-\text{grad } f_u) o(M)_a \\ &= (-1)^{i(r)+i(q)+1} \varepsilon_{f_J}(p, q)_b \varepsilon_{f_u}(q, r)_a \iota(-\text{grad } f_u) o(J \times M)_a \\ &= \varepsilon_{f_J}(p, q)_b \varepsilon_{f_u}(q, r)_a \iota(-\text{grad } f_u) o(J \times M)_a. \end{aligned}$$

Here we have used (B.5) and Lemma 9.1. This gives rise to $+\partial h (= +\partial' h)$. For a critical locus r' with $i(r') = i(q) + 1$, the broken flow line from r' to q broken at p contributes as $\varepsilon_{f_u}(r', p)_a \varepsilon_{f_J}(p, q)_b$. Indeed, the coorientation of the boundary of $\mathcal{M}'(f_J; r', q)$ is

$$\begin{aligned} & o_{J \times M}^*(\widetilde{\mathcal{D}}_{r'}(f_J))_a \wedge o_{J \times M}^*(\partial \mathcal{C} \widetilde{\mathcal{A}}_p(f_J))_a \\ &= (-1)^{i(p)+d+1} \varepsilon_{f_J}(p, q)_b o_{J \times M}^*(\widetilde{\mathcal{D}}_{r'}(f_J))_a \wedge ds \wedge o_{J \times M}^*(\widetilde{\mathcal{A}}_p(f_J))_a \\ &= (-1)^{i(p)+d+1} (-1)^{d-i(r')} \varepsilon_{f_J}(p, q)_b ds \wedge o_{J \times M}^*(\widetilde{\mathcal{D}}_{r'}(f_J))_a \wedge o_{J \times M}^*(\widetilde{\mathcal{A}}_p(f_J))_a \\ &= (-1)^{i(r')+i(p)+1} \varepsilon_{f_u}(r', p)_a ds \wedge \varepsilon_{f_J}(p, q)_b \iota(-\text{grad } f_u) o(M)_a \\ &= (-1)^{i(r')+i(p)} \varepsilon_{f_u}(r', p)_a \varepsilon_{f_J}(p, q)_b \iota(-\text{grad } f_u) o(J \times M)_a \\ &= -\varepsilon_{f_u}(r', p)_a \varepsilon_{f_J}(p, q)_b \iota(-\text{grad } f_u) o(J \times M)_a. \end{aligned}$$

Here we have used (B.5) and Lemma 9.2. This gives rise to $-h\partial' (= -h\partial)$. \square

The following corollary follows immediately from Lemma 9.3.

COROLLARY 9.4 (Lemma 5.7 of [Fuk2]). *Let g be a combinatorial propagator for $(C_*^{(u-\varepsilon)}, \partial)$. Then the endomorphism*

$$g' = (1 + h) \circ g \circ (1 - h) \in \text{End}_1(C_*^{(u+\varepsilon)})$$

is a combinatorial propagator for $(C_^{(u+\varepsilon)}, \partial')$. Moreover, by $hgh = hg'h = 0$,*

$$g' - g = hg - gh = hg' - g'h.$$

9.4. Orientations of some faces of $J \times \partial \overline{C}_{2k}(M)$. The orientations of the faces $J \times \partial_{\{i,j\}} \overline{C}_{2k}(M)$ and $J \times \partial_{\{1,2,\dots,2k\}} \overline{C}_{2k}(M)$ induced from the standard orientation $ds \wedge o(M)_{x_1} \wedge \dots \wedge o(M)_{x_{2k}}$ of $J \times M^{2k}$ are given as follows. Let $\Delta_a = \{(x_1, \dots, x_{2k}) \in M^{2k}; x_1 = \dots = x_{2k}\}$. We have

$$\begin{aligned} o(J \times \partial B\ell_{\Delta_{ij}}(M^{2k})) &= -\omega_2 \wedge ds \wedge o(\Delta_{ij}), \\ o(J \times \partial B\ell_{\Delta_a}(M^{2k})) &= -\omega_{6k-4} \wedge ds \wedge o(\Delta_a), \end{aligned} \tag{9.1}$$

where $o(\Delta_a)_{\vec{x}} = \bigwedge_{\ell=1}^3 (du_1^{(\ell)} + du_2^{(\ell)} + \dots + du_{2k}^{(\ell)})$ and $(u_i^{(1)}, u_i^{(2)}, u_i^{(3)})$ is a local coordinate around x_i . This can be checked as follows. For $\vec{x} = (x_1, x_2, \dots, x_{2k}) \in \Delta_a$, we have

$$\begin{aligned} & ds \wedge o(\Delta_a)_{\vec{x}} \wedge \bigwedge_{i=2}^{2k} (du_i^{(1)} - du_1^{(1)}) \wedge (du_i^{(2)} - du_1^{(2)}) \wedge (du_i^{(3)} - du_1^{(3)}) \\ &= (2k)^3 ds \wedge o(M^{2k})_{\vec{x}}. \end{aligned}$$

The part $\bigwedge_{i=2}^{2k} (du_i^{(1)} - du_1^{(1)}) \wedge (du_i^{(2)} - du_1^{(2)}) \wedge (du_i^{(3)} - du_1^{(3)})$ gives an orientation of the fiber of the normal bundle $N_{\Delta_a} \rightarrow \Delta_a$ and the part $ds \wedge o(\Delta_a)_{\vec{x}}$ is a 4-form. Hence the orientation of the unit sphere bundle of N_{Δ_a} induced from the left hand side of the above expression is $-ds \wedge o(\Delta_a) \wedge \omega_{6k-4}$. The orientation of $J \times \partial B\ell_{\Delta_{ij}}(M^{2k})$ is similar to that of $\partial B\ell_{\Delta_{ij}}(M^{2k})$ given in §5.4.

Now the integer $\#\mathcal{M}_T^{\text{local}}(-\text{grad } \vec{f}_J)$ is defined by the sum of signs determined by exterior products of coorientations of submanifolds of the $\overline{C}_{2k}^{\text{local}}(\mathbb{R}^3)$ -bundle over $J \times M_0$ as in Definition 2.7 and by (9.1).

9.5. Standard co-orientations of \mathcal{M}_Γ in 1-parameter family. Let Γ be a trivalent graph with $2k$ vertices and without bivalent vertices such that $0 \leq 3(2k - 3k) + \sum_{i=1}^{3k} \eta_i + 1 \leq 1$, according to Proposition 8.3. In a generic 1-parameter family (f_J, μ_J) , the moduli space $\mathcal{M}_\Gamma(\vec{f}_J)$ is a smooth manifold of dimension $3(2k - 3k) + \sum_{i=1}^{3k} \eta_i + 1$ and is the transversal intersection of the preimages of $\mathcal{M}_2(f_j)$'s and $\mathcal{N}_{pq}(f_j)$'s in $J \times C_{2k}(M)$. We may define $\sigma_{J \times C_{2k}(M)}^*(\mathcal{M}_\Gamma(\vec{f}_J))$ by the exterior product of coorientations of the preimages of $\mathcal{M}_2(f_j)$'s and $\mathcal{N}_{pq}(f_j)$'s in $J \times C_{2k}(M)$ as in §5.5.

9.6. (Co)orientations induced on $\partial \overline{\mathcal{M}}_\Gamma$. Let $(f_J, \mu_J) = \{(f_s, \mu_s)\}_{s \in J}$ be a generic 1-parameter family of Morse pairs. Let \vec{f}_J be a sequence of 1-parameter families of Morse pairs that is obtained from the tuple \vec{f} of generic Morse–Smale pairs (in the sense of Proposition 2.4) by replacing f_1 with f_J . For a graph $\Gamma \in \mathcal{G}_{2k, 3k}^0(\vec{C})$, we consider the co-orientation of $\partial \overline{\mathcal{M}}_\Gamma(\vec{f}_J)$ induced from $\sigma_{J \times M^{2k}}^*(\mathcal{M}_\Gamma(\vec{f}_J))$ defined above. Let $d''\Gamma = \sum_{e \in \text{Se}(\Gamma)} d''_e \Gamma$, where

$$d''_e \begin{array}{c} p_i \circ \\ \diagdown \quad \diagup \\ \square \\ \diagup \quad \diagdown \\ q_i \circ \end{array} = \sum_{\substack{r_i \in P_*^{(i)} \\ i(r_i) = i(p_i)}} \begin{array}{c} p_i \circ \\ \diagdown \quad \diagup \\ \square \\ \diagup \quad \diagdown \\ q_i \circ \end{array} - \sum_{\substack{s_i \in P_*^{(i)} \\ i(s_i) = i(q_i)}} \begin{array}{c} p_i \circ \\ \diagdown \quad \diagup \\ \square \\ \diagup \quad \diagdown \\ q_i \circ \end{array} \quad (\beta(i) = e)$$

and $(d''_e \Gamma)$ is the induced one. As before, we call a face of $\overline{\mathcal{M}}_\Gamma(\vec{f}_J)$ corresponding to a degeneration of one of the terms in $d\Gamma$, $d'\Gamma$, $d''\Gamma$ a *principal face*. We call a face of $\overline{\mathcal{M}}_\Gamma(\vec{f}_J)$ that is not principal a *hidden face*. When Γ consists only of compact edges, we define the *anomalous face* of $\overline{\mathcal{M}}_\Gamma(\vec{f}_J)$ as the hidden face corresponding to the collapse of all the $2k$ points. The following proposition is an analogue of Proposition 6.2.

PROPOSITION 9.5. *Suppose that $d = 3$ and that $(\vec{f}_J, \vec{\mu}_J)$ is generic as in Proposition 8.12. Let Γ be a graph in $\mathcal{G}_{2k, 3k}^0(\vec{C})$. We have*

$$\begin{aligned} & \sum_{\sigma \in \mathfrak{S}_{3k}} \sum_{\tau \subset E(\Gamma)} (-1)^{|\tau|} (\#\mathcal{M}_{\Gamma_\sigma}(\vec{f}_{s_1}) - \#\mathcal{M}_{\Gamma_\sigma}(\vec{f}_{s_0})) \\ &= \begin{cases} \sum_{\sigma, \tau} (-1)^{|\tau|} (\#\mathcal{M}_{(d-d'-d'')\Gamma_\sigma}(\vec{f}_J) + \#\mathcal{M}_{\Gamma_\sigma}^{\text{local}}(-\text{grad } \vec{f}_J)) & \text{if } E(\Gamma) = \text{Comp}(\Gamma) \\ \sum_{\sigma, \tau} (-1)^{|\tau|} \#\mathcal{M}_{(d-d'-d'')\Gamma_\sigma}(\vec{f}_J) & \text{if } E(\Gamma) \neq \text{Comp}(\Gamma) \end{cases} \end{aligned}$$

Proof. By Proposition 8.12, we know the types of the graphs that may occur at the boundary of $\overline{\mathcal{M}}_\Gamma(\vec{f}_J)$. We check that $0 = \#\partial \overline{\mathcal{M}}_\Gamma(\vec{f}_J)$ is the sum of $\#\mathcal{M}_{\Gamma_\sigma}(\vec{f}_{s_1}) - \#\mathcal{M}_{\Gamma_\sigma}(\vec{f}_{s_0}) + \#\mathcal{M}_{(-d+d'+d'')\Gamma_\sigma}(\vec{f}_J)$ and the contribution of the hidden faces.

First, we consider the contribution of $J \times \partial \overline{C}_{2k}(M)$. The vanishing of the contributions of the hidden faces that are not anomalous follows from Lemmas 6.3, 6.4 and 6.5. The contributions of the collapse of a compact edge or of the anomalous face are $-\#\mathcal{M}_{d\Gamma}(\vec{f}_J)$ and $-\#\mathcal{M}_\Gamma^{\text{local}}(-\text{grad } \vec{f}_J)$ respectively. This is immediate from the sign convention and from (9.1). The contribution of the faces $\partial_{A \cup \{\infty\}} \overline{C}_{2k}(M)$ are as follows. Recall that the interior of the face $\partial_{A \cup \{\infty\}} \overline{C}_{2k}(M)$ is diffeomorphic to the space $C_{2k-j}(M) \times C_j^\infty(\mathbb{R}^3)$ (Proof of Proposition 6.2). Let $f_j^\infty : \mathbb{R}^3 \rightarrow \mathbb{R}$ ($j = 2, \dots, 3k$) be the linear map such that $\varphi_\infty^* f_j^\infty$ agrees with f_j near ∞_M and let $f_s^\infty : \mathbb{R}^3 \rightarrow \mathbb{R}$ ($s \in J$) be the linear map such that $\varphi_{\infty s}^* f_s^\infty$ agrees with f_s near ∞_M .

Let $\vec{f}_s^\infty = (f_s^\infty, f_2^\infty, \dots, f_{3k}^\infty)$, $\vec{f}_J^\infty = \{\vec{f}_s^\infty\}_s$ and let $B = V(\Gamma) \setminus A$. Suppose that $E(\Gamma/\Gamma_B) = \text{Comp}(\Gamma/\Gamma_B)$. Let $\mathcal{M}_{\Gamma/\Gamma_B}^\infty(\vec{f}_J^\infty \setminus (\vec{f}_J^\infty)_B)$ be the space of affine graphs in $J \times \mathbb{R}^3$ modulo the dilation of \mathbb{R}^3 whose edge labeled $\ell \neq 1$ (resp. $\ell = 1$) follows the negative gradient of f_ℓ^∞ (resp. f_s^∞). Let $\pi_1 : J \times C_{2k-j}(M) \times C_j^\infty(\mathbb{R}^3) \rightarrow J \times C_{2k-j}(M)$ and $\pi_2 : J \times C_{2k-j}(M) \times C_j^\infty(\mathbb{R}^3) \rightarrow J \times C_j^\infty(\mathbb{R}^3)$ be the projections. Then the face of $\partial \overline{\mathcal{M}}_\Gamma(\vec{f}_J)$ coming from $\partial_{A \cup \{\infty\}} \overline{C}_{2k}(M)$ is diffeomorphic to

$$\pi_1^{-1} \mathcal{M}_{\Gamma_B}^\infty((\vec{f}_J)_B) \cap \pi_2^{-1} \mathcal{M}_{\Gamma/\Gamma_B}^\infty(\vec{f}_J^\infty \setminus (\vec{f}_J^\infty)_B).$$

If the number of edges in $E(\Gamma)$ that intersect both $V(\Gamma_A)$ and $V(\Gamma_B)$ is m , then the codimension of $\mathcal{M}_{\Gamma/\Gamma_B}^\infty(\vec{f}_J^\infty \setminus (\vec{f}_J^\infty)_B)$ is $3j + m$. Since $\dim J \times C_j^\infty(\mathbb{R}^3) = 3j$, m must be zero if $\mathcal{M}_{\Gamma/\Gamma_B}^\infty(\vec{f}_J^\infty \setminus (\vec{f}_J^\infty)_B) \neq \emptyset$. That $m = 0$ implies that $A = \{1, 2, \dots, 2k\}$. But in such a case Γ_B is empty and the translation in \mathbb{R}^3 acts on $\mathcal{M}_{\Gamma/\Gamma_B}^\infty(\vec{f}_J^\infty \setminus (\vec{f}_J^\infty)_B)$ freely. By a dimensional reason, this shows that $\mathcal{M}_{\Gamma/\Gamma_B}^\infty(\vec{f}_J^\infty \setminus (\vec{f}_J^\infty)_B)$ must be empty.

Next, we consider the contributions of the inner boundaries. Suppose for simplicity that separated edges of Γ are labeled $1, 2, \dots, a$. For a number ℓ in $1 \leq \ell \leq 3k$, put

$$\tilde{\Sigma}_\ell = \begin{cases} \bigcap_{\substack{1 \leq j \leq a \\ j \neq \ell}} \tilde{H}_j \cap \bigcap_{j=a+1}^{3k} \tilde{\Theta}_j & \text{if } 1 \leq \ell \leq a \\ \bigcap_{j=1}^a \tilde{H}_j \cap \bigcap_{\substack{a+1 \leq j \leq 3k \\ j \neq \ell}} \tilde{\Theta}_j & \text{if } a+1 \leq \ell \leq 3k \end{cases}$$

Then $\text{codim } \tilde{\Sigma}_\ell = \text{codim } \mathcal{M}_\Gamma(\vec{f}_J) - \text{codim } \tilde{H}_\ell = 6k - 4 \equiv 0 \pmod{2}$. Let X be a graph obtained from Γ by replacing an edge labeled ℓ with a broken edge such that $\mathcal{M}_X(\vec{f}_J)$ is 0-dimensional. We shall describe the co-orientation of the face \mathcal{S}_X of $\partial \overline{\mathcal{M}}_\Gamma(\vec{f}_J)$ corresponding to X induced from the standard co-orientation of $\mathcal{M}_\Gamma(\vec{f}_J)$ using (B.3) and (B.5). In the following, we let $\ell = 1$.

$$(1) \quad X = \begin{array}{c} p_\ell \\ \swarrow \\ r_\ell \circlearrowleft \\ \searrow \\ q_\ell \end{array} \begin{array}{c} \circlearrowright \\ \circlearrowright \\ \circlearrowright \\ \circlearrowright \end{array} \begin{array}{c} \circlearrowright \\ \circlearrowright \\ \circlearrowright \\ \circlearrowright \end{array}. \quad \text{For } \mathcal{M}_X(\vec{f}_J) \text{ to be 0-dimensional, } i(r_\ell) = i(p_\ell) - 1 \text{ or}$$

$i(r_\ell) = i(p_\ell)$. When $i(r_\ell) = i(p_\ell)$, the co-orientation of $\mathcal{F}_{r_\ell} \overline{\mathcal{M}}_\Gamma(\vec{f}_J)$ induced from the standard one

$$o_{J \times M^{2k}}^*(\mathcal{M}_\Gamma(\vec{f}_J)) = o_{J \times M}^*(\tilde{\mathcal{D}}_{p_\ell}(f_\ell)) \wedge o_{J \times M}^*(\tilde{\mathcal{A}}_{q_\ell}(f_\ell)) \wedge o_{J \times M^{2k}}^*(\tilde{\Sigma}_\ell) \quad (9.2)$$

is given by

$$\begin{aligned} & (-1)^{(d+1)-1} (-1)^{(2kd+1)-1} o_{J \times M}^*(\tilde{\mathcal{A}}_{q_\ell}(f_J)) \\ & \wedge (-1)^{i(r_\ell)} \varepsilon_{f_J}(p_\ell, r_\ell) ds \wedge o_{J \times M}^*(\tilde{\mathcal{D}}_{r_\ell}(f_J)) \wedge o_{J \times M^{2k}}^*(\tilde{\Sigma}_\ell) \\ & = (-1)^{i(q_\ell) + i(r_\ell) + d} \varepsilon_{f_J}(p_\ell, r_\ell) ds \wedge o_{J \times M}^*(\tilde{\mathcal{A}}_{q_\ell}(f_J)) \wedge o_{J \times M}^*(\tilde{\mathcal{D}}_{r_\ell}(f_J)) \wedge o_{J \times M^{2k}}^*(\tilde{\Sigma}_\ell) \\ & = \varepsilon_{f_J}(p_\ell, r_\ell) ds \wedge o_{J \times M}^*(\tilde{\mathcal{A}}_{q_\ell}(f_J)) \wedge o_{J \times M}^*(\tilde{\mathcal{D}}_{r_\ell}(f_J)) \wedge o_{J \times M^{2k}}^*(\tilde{\Sigma}_\ell). \end{aligned}$$

Here we used Lemma 9.1 and (B.3). This agrees with the standard co-orientation $o_{J \times M^{2k}}^*(\mathcal{M}_X(\vec{f}_J))$.

When $i(r_\ell) = i(p_\ell) - 1$, the co-orientation of $\mathcal{F}_{r_\ell} \overline{\mathcal{M}}_\Gamma(\vec{f}_J)$ induced from the stan-

dard one is given by

$$\begin{aligned} & (-1)^{d-1}(-1)^{(2kd+1)-1}\varepsilon_{f_{s_0}}(p_\ell, r_\ell) o_{J \times M}^*(\widetilde{\mathcal{A}}_{q_\ell}(f_J)) \\ & \quad \wedge (-1)^{i(r_\ell)} o_{J \times M}^*(\widetilde{\mathcal{D}}_{r_\ell}(f_J)) \wedge o_{J \times M^{2k}}^*(\widetilde{\Sigma}_\ell) \\ & = (-1)^{i(r_\ell)} \varepsilon_{f_{s_0}}(p_\ell, r_\ell) o_{J \times M}^*(\widetilde{\mathcal{A}}_{q_\ell}(f_J)) \wedge o_{J \times M}^*(\widetilde{\mathcal{D}}_{r_\ell}(f_J)) \wedge o_{J \times M^{2k}}^*(\widetilde{\Sigma}_\ell) \\ & = (-1)^{i(q_\ell)} \varepsilon_{f_{s_0}}(p_\ell, r_\ell) o_{J \times M}^*(\widetilde{\mathcal{A}}_{q_\ell}(f_J)) \wedge o_{J \times M}^*(\widetilde{\mathcal{D}}_{r_\ell}(f_J)) \wedge o_{J \times M^{2k}}^*(\widetilde{\Sigma}_\ell). \end{aligned}$$

Here we used Lemma 5.1 and (B.3). The sign $(-1)^{i(q_\ell)}$ agrees with the coefficient of X in $d'\Gamma$.

(2) $X = \begin{array}{c} p_\ell \\ \circ \\ \swarrow \searrow \\ s_\ell \quad \circ \\ \downarrow \uparrow \\ q_\ell \end{array} \square$. For $\mathcal{M}_X(\vec{f}_J)$ to be 0-dimensional, $i(s_\ell) = i(q_\ell) + 1$ or

$i(s_\ell) = i(q_\ell)$. When $i(s_\ell) = i(q_\ell)$, the co-orientation of $\mathcal{F}_{s_\ell} \overline{\mathcal{M}}_\Gamma(\vec{f}_J)$ induced from the standard one (9.2) is given by

$$\begin{aligned} & (-1)^{(d+1)-1}(-1)^{(2kd+1)-1}(-1)^{d-i(p_\ell)}(-1)^{i(s_\ell)+d+1} \varepsilon_{f_J}(s_\ell, q_\ell) ds \wedge o_{J \times M}^*(\widetilde{\mathcal{A}}_{s_\ell}(f_J)) \\ & \quad \wedge o_{J \times M}^*(\widetilde{\mathcal{D}}_{p_\ell}(f_J)) \wedge o_{J \times M^{2k}}^*(\widetilde{\Sigma}_\ell) \\ & = (-1)^{i(p_\ell)+i(s_\ell)+d+1} \varepsilon_{f_J}(s_\ell, q_\ell) ds \wedge o_{J \times M}^*(\widetilde{\mathcal{A}}_{s_\ell}(f_J)) \wedge o_{J \times M}^*(\widetilde{\mathcal{D}}_{p_\ell}(f_J)) \wedge o_{J \times M^{2k}}^*(\widetilde{\Sigma}_\ell) \\ & = -\varepsilon_{f_J}(s_\ell, q_\ell) ds \wedge o_{J \times M}^*(\widetilde{\mathcal{A}}_{s_\ell}(f_J)) \wedge o_{J \times M}^*(\widetilde{\mathcal{D}}_{p_\ell}(f_J)) \wedge o_{J \times M^{2k}}^*(\widetilde{\Sigma}_\ell). \end{aligned}$$

Here we used Lemma 9.2 and (B.3). This is opposite to the standard co-orientation.

When $i(s_\ell) = i(q_\ell) + 1$, the co-orientation of $\mathcal{F}_{s_\ell} \overline{\mathcal{M}}_\Gamma(\vec{f}_J)$ induced from the standard one is given by

$$\begin{aligned} & -(-1)^{d-1}(-1)^{(2kd+1)-1}(-1)^{d-i(p_\ell)} \varepsilon_{f_{s_0}}(s_\ell, q_\ell) o_{J \times M}^*(\widetilde{\mathcal{A}}_{s_\ell}(f_J)) \\ & \quad \wedge o_{J \times M}^*(\widetilde{\mathcal{D}}_{p_\ell}(f_J)) \wedge o_{J \times M^{2k}}^*(\widetilde{\Sigma}_\ell) \\ & = (-1)^{i(s_\ell)} \varepsilon_{f_{s_0}}(s_\ell, q_\ell) o_{J \times M}^*(\widetilde{\mathcal{A}}_{s_\ell}(f_J)) \wedge o_{J \times M}^*(\widetilde{\mathcal{D}}_{p_\ell}(f_J)) \wedge o_{J \times M^{2k}}^*(\widetilde{\Sigma}_\ell). \end{aligned}$$

Here, we used Lemma 5.2 and (B.3). The sign $(-1)^{i(s_\ell)}$ agrees with the coefficient of X in $d'\Gamma$.

(3) $X = \begin{array}{c} \diagup \quad \diagdown \\ \circ \\ \diagdown \quad \diagup \\ \circ \\ \diagup \quad \diagdown \end{array} r_\ell$. The induced co-orientation on the boundary is as in Lemma 5.4,

which differs from the standard co-orientation by $(-1)^{2d-1}(-1)^{(2kd+1)-1}(-1)^{i(r_\ell)+1} = (-1)^{i(r_\ell)}$.

Now we have seen that the signs in the formula of the definitions of d' and d'' are consistent with the induced co-orientations on the boundary of $\overline{\mathcal{M}}_\Gamma(\vec{f}_J)$. \square

10. Proof of main theorem. We shall prove that $\widehat{Z}_{2k,3k}(\vec{f})$ is invariant under bifurcations of types (1), (2), (3), (4) in Lemma 8.2 and complete the proof of Theorem 2.13.

10.1. Invariance on ordered 1-parameter family without i/i -intersections. We check the invariance of $\widehat{Z}_{2k,3k}(\vec{f})$ with respect to bifurcations of type (4) for different Morse indices in Lemma 8.2.

LEMMA 10.1. *Suppose that a generic 1-parameter family $\{(f_s, \mu_s)\}_{s \in J}$, $J = [s_0, s_1]$, of Morse pairs is ordered and has no i/i -intersections over J . Then*

$$\widehat{Z}_{2k,3k}(\vec{f}_{s_0}) = \widehat{Z}_{2k,3k}(\vec{f}_{s_1}).$$

Proof. Note that the moduli space $\mathcal{M}_{d'\Gamma}(\vec{f}_J)$ is empty since f_J has no i/i -intersections. By Proposition 9.5, the difference $Z_{2k,3k}(\vec{f}_{s_1}) - Z_{2k,3k}(\vec{f}_{s_0})$ equals

$$\mathrm{Tr}_{\vec{g}} \left[\sum_{\Gamma \in \mathcal{G}_{2k,3k}^0(\vec{C})} \# \mathcal{M}_{(d-d')\Gamma}(\vec{f}_J) \Gamma \right] + Z_{2k,3k}^{\mathrm{anomaly}}(-\mathrm{grad} \vec{f}_J).$$

As in the proof of Lemma 6.1, the sum $\mathrm{Tr}_{\vec{g}} \left[\sum_{\Gamma \in \mathcal{G}_{2k,3k}^0(\vec{C})} \# \mathcal{M}_{d\Gamma}(\vec{f}_J) \Gamma \right]$ vanishes by the IHX relation. Moreover, $\mathrm{Tr}_{\vec{g}} \left[\sum_{\Gamma \in \mathcal{G}_{2k,3k}^0(\vec{C})} \# \mathcal{M}_{d\Gamma}(\vec{f}_J) \Gamma \right]$ equals

$$\mathrm{Tr}_{\vec{g}} \left[\sum_{i=1}^{3k} \sum_{\substack{\Gamma'(\tilde{p}_i, \tilde{q}_i)_i \\ i(\tilde{p}_i)=i(\tilde{q}_i)}} (-1)^{i(\tilde{p}_i)} \# \mathcal{M}_{\Gamma'(\tilde{p}_i, \tilde{q}_i)_i}(\vec{f}_J) d^* \Gamma'(\tilde{p}_i, \tilde{q}_i)_i \right],$$

where the second sum is taken over graphs of degree $(\eta_1, \dots, \eta_{3k})$, $\eta_j = 1$ ($j \neq i$), $\eta_i = 0$, such that $\beta(i) \in \mathrm{Se}(\Gamma)$, and $d^* \Gamma'(\tilde{p}_i, \tilde{q}_i)_i$ denotes

$$\sum_{\substack{x_i \in P_*^{(i)} \\ i(x_i)=i(\tilde{p}_i)+1}} \partial_{x_i \tilde{p}_i}^{(i)} \Gamma'(x_i, \tilde{q}_i)_i + \sum_{\substack{y_i \in P_*^{(i)} \\ i(y_i)=i(\tilde{q}_i)-1}} \partial_{\tilde{q}_i y_i}^{(i)} \Gamma'(\tilde{p}_i, y_i)_i + \delta_{\tilde{p}_i \tilde{q}_i} \Gamma'(\emptyset, \emptyset)_i.$$

For each fixed pair $\tilde{p}_i, \tilde{q}_i \in P_*^{(i)}$ with $i(\tilde{p}_i) = i(\tilde{q}_i)$, we have

$$\begin{aligned} & \mathrm{Tr}_{\vec{g}} \left[\sum_{\substack{x_i \in P_*^{(i)} \\ i(x_i)=i(\tilde{p}_i)+1}} \partial_{x_i \tilde{p}_i}^{(i)} \Gamma'(x_i, \tilde{q}_i)_i + \sum_{\substack{y_i \in P_*^{(i)} \\ i(y_i)=i(\tilde{q}_i)-1}} \partial_{\tilde{q}_i y_i}^{(i)} \Gamma'(\tilde{p}_i, y_i)_i + \delta_{\tilde{p}_i \tilde{q}_i} \Gamma'(\emptyset, \emptyset)_i \right] \\ &= \mathrm{Tr}_{\dots, \partial^{(i)} g^{(i)} + g^{(i)} \partial^{(i)}, \dots} \left[\Gamma'(\tilde{p}_i, \tilde{q}_i)_i \right] + \mathrm{Tr}_{\vec{g}} \left[\delta_{\tilde{p}_i \tilde{q}_i} \Gamma'(\emptyset, \emptyset)_i \right] \\ &= \mathrm{Tr}_{\dots, \mathrm{id}, \dots} \left[\Gamma'(\tilde{p}_i, \tilde{q}_i)_i \right] + \mathrm{Tr}_{\vec{g}} \left[\delta_{\tilde{p}_i \tilde{q}_i} \Gamma'(\emptyset, \emptyset)_i \right] = \delta_{\tilde{p}_i \tilde{q}_i} \mathrm{Tr}_{\vec{g}} \left[-\Gamma'(\emptyset, \emptyset)_i + \Gamma'(\emptyset, \emptyset)_i \right] = 0. \end{aligned}$$

Hence we have

$$Z_{2k,3k}(\vec{f}_{s_1}) - Z_{2k,3k}(\vec{f}_{s_0}) = Z_{2k,3k}^{\mathrm{anomaly}}(-\mathrm{grad} \vec{f}_J).$$

For the correction terms of $\widehat{Z}_{2k,3k}(\vec{f}_{s_0})$ and $\widehat{Z}_{2k,3k}(\vec{f}_{s_1})$, we may choose the same spin 4-manifold W . Then we choose generic GM sections $\vec{\gamma}_W$ and $\vec{\gamma}'_W$ of $\Gamma(T^v W)^{3k}$ as in §2.8.1 that are extensions of $-\mathrm{grad} \vec{f}_{s_0}$ and $-\mathrm{grad} \vec{f}_{s_1}$ respectively. Then it follows from Lemma 7.2 that

$$Z_{2k,3k}^{\mathrm{anomaly}}(\vec{\gamma}'_W) - Z_{2k,3k}^{\mathrm{anomaly}}(\vec{\gamma}_W) - Z_{2k,3k}^{\mathrm{anomaly}}(-\mathrm{grad} \vec{f}_J) = 0.$$

This completes the proof. \square

10.2. Invariance at level exchange bifurcation. We check the invariance of $\widehat{Z}_{2k,3k}(\vec{f})$ with respect to bifurcations of type (1) in Lemma 8.2.

LEMMA 10.2. *Suppose that $s_0 \in J$ is a level exchange bifurcation for the generic 1-parameter family $\{(f_s, \mu_s)\}_{s \in J}$ of Morse pairs. If ε is sufficiently small,*

$$\widehat{Z}_{2k,3k}(\vec{f}_{s_0-\varepsilon}) = \widehat{Z}_{2k,3k}(\vec{f}_{s_0+\varepsilon}).$$

The proof is the same as Lemma 10.1.

10.3. Invariance at birth-death bifurcation. We check the invariance of $\widehat{Z}_{2k,3k}(\vec{f})$ with respect to bifurcations of type (2) in Lemma 8.2.

We say that a birth-death point v in a 1-parameter family $\{(f_s, \mu_s)\}_{s \in [0,1]}$, say at $s = s_0$, is *independent* if on a neighborhood of s_0 in $[0,1]$ the descending and the ascending manifold of v are disjoint from all the other descending and ascending manifolds of critical points. The following lemma is an immediate consequence of [HW, page 62].

LEMMA 10.3. *A 1-parameter family $\{(f_s, \mu_s)\}_{s \in [0,1]}$ of pairs of generalized Morse functions and metrics on M_0 can be deformed so that every birth-death points are independent.*

LEMMA 10.4. *Suppose that $s_0 \in J$ is a parameter on which an independent birth-death point v occurs in a generic 1-parameter family. If ε is sufficiently small,*

$$\widehat{Z}_{2k,3k}(\vec{f}_{s_0-\varepsilon}) = \widehat{Z}_{2k,3k}(\vec{f}_{s_0+\varepsilon}).$$

Proof. We prove the lemma only for death point since the case of birth point is symmetric. If (p, q) is the critical point pair at $s = s_0 - \varepsilon$ that disappears on $s > s_0$, then the Morse complex at $s = s_0 - \varepsilon$ is the direct sum $C_*^{(s_0+\varepsilon)} \oplus C_*^{\text{elem}}$, where $C_*^{(s_0+\varepsilon)} = (C_*^{(s_0+\varepsilon)}, \partial^{(s_0+\varepsilon)})$ is the Morse complex at $s = s_0 + \varepsilon$ and

$$C_*^{\text{elem}} = \{0 \rightarrow C_{i+1}^{\text{elem}} = \mathbb{Z}\{p\} \xrightarrow{\cong} C_i^{\text{elem}} = \mathbb{Z}\{q\} \rightarrow 0\}.$$

Choose a combinatorial propagator g of $C_*^{(s_0+\varepsilon)}$. The acyclic complex C_*^{elem} has a unique combinatorial propagator g^{elem} defined by $g^{\text{elem}}(q) = p$. We consider g and g^{elem} as homogeneous degree 1 maps of $C_*^{(s_0+\varepsilon)} \oplus C_*^{\text{elem}}$ by setting $g(C_*^{\text{elem}}) = 0$ and $g^{\text{elem}}(C_*^{(s_0+\varepsilon)}) = 0$. Then one can check that $g' = g + g^{\text{elem}}$ is a combinatorial propagator for $C_*^{(s_0+\varepsilon)} \oplus C_*^{\text{elem}}$.

Since v is independent, we need only to check the identity of the lemma in the case where a gluing of trajectories happens at v . Suppose that the separated edge labeled by 1 in a flow graph of $\Gamma(p, q)_1 \in \mathcal{G}_{2k,3k}^0(\vec{C}^{(s_0-\varepsilon)})$ converges to a broken edge as $s \rightarrow s_0$ and that p and q converges to v . Then by Proposition 8.13 we have

$$\begin{aligned} & \text{Tr}_{g', \dots}(\Gamma(p, q)_1) \cdot \#\overline{\mathcal{M}}_{\Gamma(p, q)_1}(\vec{f}_{s_0-\varepsilon}) + \text{Tr}_{g', \dots}(\Gamma(\emptyset, \emptyset)_1) \cdot \#\overline{\mathcal{M}}_{\Gamma(\emptyset, \emptyset)_1}(\vec{f}_{s_0-\varepsilon}) \\ &= \text{Tr}_{g, \dots}(\Gamma(\emptyset, \emptyset)_1) \left(-\#\overline{\mathcal{M}}_{\Gamma(p, q)_1}(\vec{f}_{s_0-\varepsilon}) + \#\overline{\mathcal{M}}_{\Gamma(\emptyset, \emptyset)_1}(\vec{f}_{s_0-\varepsilon}) \right) \\ &= \text{Tr}_{g, \dots}(\Gamma(\emptyset, \emptyset)_1) \cdot \#\overline{\mathcal{M}}_{\Gamma(\emptyset, \emptyset)_1}(\vec{f}_{s_0+\varepsilon}). \end{aligned} \quad (10.1)$$

Here, we must check that the signs of the boundaries of the 1-cobordism are correct. It suffices to check the coorientations for the standard model h_u in §8.4 for a 1-parameter family around a death bifurcation. For $u < 0$ with $|u|$ small and for $x = (x_1, \dots, x_d) \in \mathcal{A}_{p_+}(h_u), y = (y_1, \dots, y_d) \in \mathcal{D}_{p_-}(h_u)$, put

$$o_M^*(\mathcal{A}_{p_+}(h_u))_x = \alpha dx_2 \cdots dx_i, \quad o_M^*(\mathcal{D}_{p_-}(h_u))_y = \beta dy_{i+1} \cdots dy_d \quad (\alpha, \beta \in \{-1, 1\}).$$

By convention, $o_{M \times M}^*(\mathcal{N}_{p_- p_+}(h_u))_{(x, y)} = o_M^*(\mathcal{A}_{p_+}(h_u))_x \wedge o_M^*(\mathcal{D}_{p_-}(h_u))_y$. On the other hand,

$$\begin{aligned} & o_M^*(\mathcal{D}_{p_-}(h_u))_x \wedge o_M^*(\mathcal{A}_{p_+}(h_u))_x = \alpha\beta dx_{i+1} \cdots dx_d dx_2 \cdots dx_i \\ &= (-1)^{i-1} \alpha\beta dx_2 \cdots dx_d = (-1)^{i-1} \alpha\beta \iota\left(\frac{\partial}{\partial x_1}\right) o(\mathbb{R}^d)_x. \end{aligned}$$

Hence $\varepsilon_{h_u}(p_-, p_+) = (-1)^{i-1} \alpha \beta$. For $u > 0$ small, consider points $x' = (x'_1, \dots, x'_d), y' = (y'_1, \dots, y'_d) \in \mathbb{R}^d$ such that x' is close to x , y' is close to y and $y' = \Phi_{h_u}^i(x')$. By using the explicit solution (8.4) and by convention, $o(\mathcal{M}_2(h_u))_{(x', y')}$ is given by

$$(dx'_1 + \delta(x'_1)dy'_1) \wedge \bigwedge_{k=2}^i (dx'_k + e^t dy'_k) \wedge \bigwedge_{k=i+1}^d (dx'_k + e^{-t} dy'_k) \wedge (-dh_u)_{y'},$$

where $\delta(x'_1) = \partial\gamma_1(t)/\partial x'_1$. Then

$$\begin{aligned} & o(\mathcal{M}_2(h_u))_{(x', y')} \wedge dx'_2 \cdots dx'_i \wedge dy'_{i+1} \cdots dy'_d \\ &= (-1)^{i-1} (e^t)^{i-1} (-y_1^2 - u) dx'_1 \cdots dx'_d dy'_1 \cdots dy'_d. \end{aligned}$$

Assuming that x', y' converge to x, y respectively as $u \rightarrow 0$, the coorientation $\lim_{u \rightarrow 0^+} o_{M \times M}^*(\mathcal{M}_2(h_u))_{(x', y')}$ is equivalent to

$$\lim_{u \rightarrow 0^-} -\varepsilon_{h_u}(p_-, p_+) o_M^*(\mathcal{A}_{p_+}(h_u))_x \wedge o_M^*(\mathcal{D}_{p_-}(h_u))_y.$$

This shows that the signs in (10.1) are correct. The proof of the invariance of the other terms in $\widehat{Z}_{2k, 3k}(\vec{f}_{s_0-\varepsilon})$ is the same as Lemma 10.1 since v is independent. \square

10.4. Invariance at i/i -intersection. We check the invariance of $\widehat{Z}_{2k, 3k}(\vec{f})$ with respect to bifurcations of type (3) in Lemma 8.2.

LEMMA 10.5. *Suppose that $s_0 \in J$ is a point on which an i/i -intersection between critical points (loci) p and q occurs in a generic 1-parameter family $\{(f_s, \mu_s)\}_{s \in J}$. If $\varepsilon > 0$ is sufficiently small, then*

$$\widehat{Z}_{2k, 3k}(\vec{f}_{s_0-\varepsilon}) = \widehat{Z}_{2k, 3k}(\vec{f}_{s_0+\varepsilon}).$$

Proof. By Proposition 9.5, we may assume without loss of generality that

$$\sum_{\sigma \in \mathfrak{S}_{3k}} \sum_{\tau \subset E(\Gamma)} \left(\# \overline{\mathcal{M}}_{\Gamma_\sigma}(\vec{f}_{s_0+\varepsilon}) - \# \overline{\mathcal{M}}_{\Gamma_\sigma}(\vec{f}_{s_0-\varepsilon}) + \# \overline{\mathcal{M}}_{d''\Gamma_\sigma}(\vec{f}_J) \right) = 0$$

if ε is sufficiently small. Let g, g' be the combinatorial propagators considered in §9.3 and put $\vec{g} = (g, g_2, \dots, g_{3k}), \vec{g}' = (g', g_2, \dots, g_{3k}), \vec{C} = (C_*^{(s_0-\varepsilon)}, C_*^{(2)}, \dots, C_*^{(3k)})$ and $\vec{C}' = (C_*^{(s_0+\varepsilon)}, C_*^{(2)}, \dots, C_*^{(3k)})$. Using Corollary 9.4 we have

$$\begin{aligned} & \sum_{\Gamma \in \mathcal{G}_{2k, 3k}^0(\vec{C})} \text{Tr}_{\vec{g}'}(\Gamma) \cdot \# \overline{\mathcal{M}}_\Gamma(\vec{f}_{s_0+\varepsilon}) - \sum_{\Gamma \in \mathcal{G}_{2k, 3k}^0(\vec{C}')} \text{Tr}_{\vec{g}}(\Gamma) \cdot \# \overline{\mathcal{M}}_\Gamma(\vec{f}_{s_0-\varepsilon}) \\ &= \sum_{\Gamma} \text{Tr}_{\vec{g}'}(\Gamma) \cdot \left(\# \overline{\mathcal{M}}_\Gamma(\vec{f}_{s_0-\varepsilon}) - \# \overline{\mathcal{M}}_{d''\Gamma}(\vec{f}_J) \right) - \sum_{\Gamma} \text{Tr}_{\vec{g}}(\Gamma) \cdot \# \overline{\mathcal{M}}_\Gamma(\vec{f}_{s_0-\varepsilon}) \\ &= \sum_{\Gamma} \text{Tr}_{g'-g, \dots}(\Gamma) \cdot \# \overline{\mathcal{M}}_\Gamma(\vec{f}_{s_0-\varepsilon}) - \sum_{\Gamma} \text{Tr}_{\vec{g}'}(\Gamma) \cdot \# \overline{\mathcal{M}}_{d''\Gamma}(\vec{f}_J) \\ &= \sum_{\Gamma} \text{Tr}_{hg'-g'h, \dots}(\Gamma) \cdot \# \overline{\mathcal{M}}_\Gamma(\vec{f}_{s_0-\varepsilon}) - \sum_{\Gamma} \text{Tr}_{\vec{g}'}(\Gamma) \cdot \# \overline{\mathcal{M}}_{d''\Gamma}(\vec{f}_J) \\ &= \text{Tr}_{g', \dots} \left[\sum_{\substack{p_1, q_1 \\ i(p_1)=i(q_1)+1}} \sum_{\Gamma(p_1, q_1)_1} \Gamma(p_1, q_1)_1 \cdot \# \overline{\mathcal{M}}_{(h*\Gamma - \Gamma*h)(p_1, q_1)_1}(\vec{f}_J) \right] \\ & \quad - \text{Tr}_{\vec{g}'} \left[\sum_{\substack{p_1, q_1 \\ i(p_1)=i(q_1)+1}} \sum_{\Gamma(p_1, q_1)_1} \Gamma(p_1, q_1)_1 \cdot \# \overline{\mathcal{M}}_{d''\Gamma(p_1, q_1)_1}(\vec{f}_J) \right] = 0. \end{aligned}$$

This completes the proof. \square

Proof of Theorem 2.13. Lemmas 10.1, 10.2, 10.4, 10.5 show that $\widehat{Z}_{2k,3k}(\vec{f}_s)$ is invariant under all possible bifurcations listed in §8.1. This completes the proof. \square

Appendix A. Some facts on smooth manifolds with corners.

We follow the convention in [BT, Appendix] for manifolds with corners, smooth maps between them and their transversality. We write down some necessary terms from [BT, Appendix], some of which are specialized than those in [BT, Appendix].

DEFINITION A.1.

- (1) A map between manifolds with corners is *smooth* if it has a local extension, at any point of the domain, to a smooth map from a manifold without boundary, as usual.
- (2) Let Y, Z be smooth manifolds with corners, and let $f : Y \rightarrow Z$ be a bijective smooth map. This map is a *diffeomorphism* if both f and f^{-1} are smooth.
- (3) Let Y, Z be smooth manifolds with corners, and let $f : Y \rightarrow Z$ be a smooth map. This map is *strata preserving* if the inverse image by f of a connected component S of a stratum of Z is a union of connected components of strata of Y .
- (4) Let X, Y be smooth manifolds with corners and Z be a smooth manifold without boundary. Let $f : X \rightarrow Z$ and $g : Y \rightarrow Z$ be smooth maps. Say that f and g are (*strata*) *transversal* when the following is true: Let U and V be connected components in strata of X and Y respectively. Then $f : U \rightarrow S$ and $g : V \rightarrow S$ are transversal.

We use the following proposition, which is a corollary of [BT, Proposition A.5].

PROPOSITION A.2. *Let X, Y be smooth manifolds with corners and Z be a smooth manifold without boundary. Let $f : X \rightarrow Z$ and $g : Y \rightarrow Z$ be smooth maps that are transversal. Then the fiber product*

$$X \times_Z Y = \{(x, y); f(x) = g(y)\} \subset X \times Y$$

is a smooth manifold with corners, whose strata have the form $U \times_Z V$ where $U \subset X$ and $V \subset Y$ are strata.

If f, g are inclusions then $X \times_Z Y = (X \times Y) \cap \Delta_Z = \Delta_{X \cap Y}$, which is canonically diffeomorphic to $X \cap Y$. Thus we obtain the following corollary.

COROLLARY A.3. *Let X, Y be smooth manifolds with corners that are submanifolds of a smooth manifold Z without boundary. Suppose that the inclusions $X \rightarrow Z$ and $Y \rightarrow Z$ are transversal. Then the intersection $X \cap Y$ is a smooth manifold with corners, whose strata have the form $U \cap V$ where $U \subset X$ and $V \subset Y$ are strata.*

The following elementary proposition is useful.

PROPOSITION A.4. *Let Z be a smooth manifold without boundary and let X be a compact smooth submanifold of Z with corners. Suppose that $\dim X > 0$. Then the closure of the codimension 0 stratum $\text{Int } X$ of X in Z agrees with X .*

Proof. Let $n = \dim X$ and $N = \dim Z$. Let

$$\mathbb{R}^n \langle m \rangle = \{(x_1, \dots, x_n); x_1 \geq 0, \dots, x_m \geq 0\} \subset \mathbb{R}^n \quad (m \leq n).$$

Choose an open covering $\{O_\lambda\}_\lambda$ of X by small open N -disks O_λ in Z , say by open ε -balls with respect to the geodesic distance for a Riemannian metric on Z for small ε , so that for each λ there is a chart $\varphi_\lambda : O_\lambda \rightarrow \varphi_\lambda(O_\lambda) \subset \mathbb{R}^N$ such that the restriction $\varphi_\lambda|_{O_\lambda \cap X} : O_\lambda \cap X \rightarrow \mathbb{R}^N$ factors as $\iota \circ \phi_\lambda$ where $\phi_\lambda : O_\lambda \cap X \rightarrow \mathbb{R}^n \langle m_\lambda \rangle$ is a chart and $\iota : \mathbb{R}^n \rightarrow \mathbb{R}^N$ is the inclusion $(x_1, \dots, x_n) \mapsto (x_1, \dots, x_n, 0, \dots, 0)$.

The codimension 0 stratum $\text{Int } X$ of X is the union of preimages of $\iota(\text{Int } \mathbb{R}^n \langle m_\lambda \rangle)$ under charts $\varphi_\lambda : \text{Int } X = \bigcup_\lambda O_\lambda \cap \varphi_\lambda^{-1} \iota(\text{Int } \mathbb{R}^n \langle m_\lambda \rangle)$. The relation $\overline{\text{Int } X} \subset X$ follows immediately from definition of the closure and the compactness of X . We prove the converse. Since X is compact in Z , there is a finite subcovering $\{O_{\lambda_1}, \dots, O_{\lambda_r}\}$ of X . Then we have

$$\begin{aligned} \overline{\text{Int } X} &= \bigcup_{i=1}^r \overline{O_{\lambda_i} \cap \varphi_{\lambda_i}^{-1} \iota(\text{Int } \mathbb{R}^n \langle m_{\lambda_i} \rangle)} = \bigcup_{i=1}^r \overline{\varphi_{\lambda_i}^{-1} \varphi_{\lambda_i}(O_{\lambda_i}) \cap \iota(\text{Int } \mathbb{R}^n \langle m_{\lambda_i} \rangle)} \\ &\supset \bigcup_{i=1}^r \overline{\varphi_{\lambda_i}^{-1} (\varphi_{\lambda_i}(O_{\lambda_i}) \cap \iota(\mathbb{R}^n \langle m_{\lambda_i} \rangle))} = \bigcup_{i=1}^r \overline{O_{\lambda_i} \cap \varphi_{\lambda_i}^{-1} \iota(\mathbb{R}^n \langle m_{\lambda_i} \rangle)} = X. \end{aligned}$$

Here at the first equality we have used the identity $\overline{A_1 \cup \dots \cup A_r} = \overline{A_1} \cup \dots \cup \overline{A_r}$ for arbitrary subsets A_1, \dots, A_r ($r < \infty$) of a topological space, and between the first and the second line we have used the relation $\overline{O \cap A} \supset O \cap \overline{A}$ for O open, A arbitrary, and the assumption $n \geq 1$. \square

Appendix B. Orientations on manifolds and their intersections. For a d -dimensional orientable manifold M , we will represent an orientation on M by a nowhere vanishing d -form of $\Omega_{\text{dR}}^d(M)$ and denote by $o(M)$. If M is a submanifold of an oriented Riemannian e -dimensional manifold E and if (v_1, \dots, v_e) is an orthonormal frame on a neighborhood of $x \in M$ such that v_1, \dots, v_d spans TM , then we may define $o(M)_x = \pm v_1^* \wedge \dots \wedge v_d^*$, where v_1^*, \dots, v_e^* is the dual basis. We may alternatively define $o(M)$ from an orientation $o_E^*(M)$ of the normal bundle of M by the rule

$$o(M) \wedge o_E^*(M) \sim o(E). \tag{B.1}$$

Note that $o_E^*(M)$ is defined canonically by the Hodge star operator: $o_E^*(M) = *o(M)$. $o_E^*(M)$ is called a *coorientation* of M in E . We assume that (B.1) is always satisfied so that coorientation is just an alternative way to represent orientation.

Let N be an oriented smooth manifold and let $\pi : N \rightarrow E$ be a smooth map that is transversal to M . Then the preimage $\pi^{-1}M$ is naturally an oriented submanifold of N . We may define the coorientation of $\pi^{-1}M$ by $\pi^*o_E^*(M)$. We denote simply by $o_E^*(M)$ the coorientation $\pi^*o_E^*(M)$. For example, if $N = D \times E$ for an oriented manifold D and if $\pi : D \times E \rightarrow E$ is the projection, then $D \times M = \pi^{-1}M$ is naturally cooriented by $o_E^*(M)$.

If M has boundary ∂M , we provide an induced orientation on ∂M from $o(M)$ as follows: let n be an outward normal vector field on ∂M , then we define

$$o(\partial M)_x = \iota(n_x)o(M)_x. \tag{B.2}$$

In other words, if n_x^* is the dual of n_x with respect to the metric and if $o(M)_x = n_x^* \wedge \alpha_x$ for $\alpha_x \in \Omega_{\text{dR}}^{d-1}(\partial M)$, then $o(\partial M)_x = \alpha_x$. This gives

$$o_E^*(\partial M)_x = (-1)^{e-1} o_E^*(M)_x \wedge n_x^*. \tag{B.3}$$

Suppose M and M' are two cooriented submanifolds of E of dimension i and j that intersect transversally. The transversality implies that at an intersection point x , the form $o_E^*(M)_x \wedge o_E^*(M')_x$ is a non-trivial $(2e - i - j)$ -form. We define

$$o_E^*(M \pitchfork M')_x = o_E^*(M)_x \wedge o_E^*(M')_x. \tag{B.4}$$

This depends on the order of the product. Note that if M and M' may have boundaries, then by (B.3), the induced coorientations on $\partial(M \pitchfork M')$ is

$$\begin{aligned} o_E^*(\partial M \pitchfork M')_x &= (-1)^{\deg o_E^*(M')_x} o_E^*(\partial M)_x \wedge o_E^*(M')_x, \\ o_E^*(M \pitchfork \partial M')_x &= o_E^*(M)_x \wedge o_E^*(\partial M')_x. \end{aligned} \tag{B.5}$$

Appendix C. The complex of endomorphisms of an acyclic complex. For a finitely generated, based free acyclic chain complex (C_*, ∂) , $C_i = \mathbb{Z}^{P_i}$, we consider the \mathbb{Z} -module $\text{End}_k(C_*)$ of endomorphisms $C_* \rightarrow C_{*+k}$ of homogeneous degree k . The boundary operator $\partial' : \text{End}_k(C_*) \rightarrow \text{End}_{k-1}(C_*)$ is defined by

$$\partial' f = \partial \circ f + (-1)^{k+1} f \circ \partial.$$

Then the pair $(\text{End}_*(C_*), \partial')$ forms a chain complex. By the canonical isomorphism $\text{End}_k(C_*) \cong \bigoplus_{i \in \mathbb{Z}} C_{i+k} \otimes \text{Hom}(C_i, \mathbb{Z})$ of chain complexes and the Künneth theorem, one can show that the complex $(\text{End}_*(C_*), \partial')$ is acyclic. For example, $f \in \text{End}_0(C_*)$ is a cycle iff $\partial' f = \partial f - f \partial = 0$. In particular, $\text{id} \in \text{End}_0(C_*)$ is a cycle and hence is a boundary. So there exists $g \in \text{End}_1(C_*)$ such that

$$\partial' g = \partial g + g \partial = \text{id}.$$

If two such endomorphisms g, g' are given, then the difference $g - g'$ is a ∂' -cycle, since $\partial'(g - g') = \text{id} - \text{id} = 0$. So there exists $h \in \text{End}_2(C_*)$ such that

$$\partial' h = \partial h - h \partial = g - g'.$$

Appendix D. Blow-up.

D.1. Blow-up of the origin in \mathbb{R}^i . Let $\tilde{\gamma}^1(\mathbb{R}^i)$ denote the total space of the tautological oriented half-line $([0, \infty))$ bundle over the oriented Grassmannian $\tilde{G}_1(\mathbb{R}^i) \cong S^{i-1}$. Namely, $\tilde{\gamma}^1(\mathbb{R}^i) = \{(x, y) \in S^{i-1} \times \mathbb{R}^i; \exists t \in [0, \infty), y = tx\}$. Then the tautological bundle is trivial and that $\tilde{\gamma}^1(\mathbb{R}^i)$ is diffeomorphic to $S^{i-1} \times [0, \infty)$. Let

$$Bl(\mathbb{R}^i, \{0\}) = \tilde{\gamma}^1(\mathbb{R}^i)$$

and call $Bl(\mathbb{R}^i, \{0\})$ the *blow-up* of 0 in \mathbb{R}^i . Let $\pi : \tilde{\gamma}^1(\mathbb{R}^i) \rightarrow \mathbb{R}^i$ be the map defined by $\pi = \text{pr}_2 \circ \varphi$ in the following commutative diagram:

$$\begin{array}{ccccc} \tilde{\gamma}^1(\mathbb{R}^i) & \xrightarrow{\varphi} & S^{i-1} \times \mathbb{R}^i & \xrightarrow{\text{pr}_1} & S^{i-1} \\ & \searrow \pi & \downarrow \text{pr}_2 & & \\ & & \mathbb{R}^i & & \end{array}$$

where $\varphi : \tilde{\gamma}^1(\mathbb{R}^i) \rightarrow S^{i-1} \times \mathbb{R}^i$ is the embedding which maps a pair $(x, y) \in S^{i-1} \times \mathbb{R}^i$ with $y = tx$ to (x, y) . If $y \neq 0$, then $\varphi(x, y) = (\frac{y}{|y|}, y)$. We call π the *projection* of the blow-up. Here, $\pi^{-1}(0) = \partial \tilde{\gamma}^1(\mathbb{R}^i)$ is the image of the zero section of the tautological bundle $\text{pr}_1 \circ \varphi : \tilde{\gamma}^1(\mathbb{R}^i) \rightarrow S^{i-1}$ and is diffeomorphic to S^{i-1} .

LEMMA D.1.

- (1) *The restriction of π to the complement of $\pi^{-1}(0) = \partial \tilde{\gamma}^1(\mathbb{R}^i)$ is a diffeomorphism onto $\mathbb{R}^i - \{0\}$.*
- (2) *The restriction of φ to the complement of $\pi^{-1}(0)$ has the image in $S^{i-1} \times \mathbb{R}^i$ whose closure agrees with the full image of φ from $\tilde{\gamma}^1(\mathbb{R}^i)$.*

D.2. Blow-up of $\mathbb{R}^i \subset \mathbb{R}^d$. When $d > i \geq 0$, we put $B\ell(\mathbb{R}^d, \mathbb{R}^i) = \tilde{\gamma}^1(\mathbb{R}^{d-i}) \times \mathbb{R}^i$ (the blow-up of \mathbb{R}^i in \mathbb{R}^d) and define the projection $\varpi : B\ell(\mathbb{R}^d, \mathbb{R}^i) \rightarrow \mathbb{R}^d$ by $\pi \times \text{id}_{\mathbb{R}^i}$. This can be straightforwardly extended to the blow-up $B\ell(Y, X)$ of a submanifold X in a manifold Y , by replacing the normal bundle with the associated $\tilde{\gamma}^1(\mathbb{R}^d)$ -bundle over X .

Acknowledgments. I would like to thank Professor Kenji Fukaya for encouraging me to write my result for publication. I would also like to thank Professor Masamichi Takase for valuable comments on spin 4-manifolds and would like to thank Professors Katrin Wehrheim and Tatsuro Shimizu for helpful comments. I am deeply grateful to the referees for the careful reading and for helpful comments. During the preparation and the revision of this paper, I have been supported by JSPS Grant-in-Aid for Young Scientists (B) 23740040 and 26800041.

REFERENCES

- [AS] S. AXELROD AND I. M. SINGER, *Chern–Simons perturbation theory*, in Proceedings of the XXth DGM Conference, Catto S., Rocha A. (eds.), pp. 3–45, World Scientific, Singapore, 1992, II, J. Diff. Geom., 39 (1994), pp. 173–213.
- [BN1] D. BAR-NATAN, *Perturbative Aspects of the Chern–Simons Topological Quantum Field Theory*, Ph.D. Thesis, Princeton University, 1991.
- [BN2] D. BAR-NATAN, *On the Vassiliev knot invariants*, Topology, 34:2 (1995), pp. 423–472.
- [BGRT] D. BAR-NATAN, S. GAROUFALIDIS, L. ROZANSKY, AND D. THURSTON, *The Århus integral of rational homology 3-spheres. II. Invariance and universality*, Selecta Math. (N.S.), 8:3 (2002), pp. 341–371.
- [BC] M. BETZ AND R. COHEN, *Graph Moduli Spaces and Cohomology Operations*, Turkish J. Math., 18 (1995), pp. 23–41.
- [Bo] R. BOTT, *Morse theory indomitable*, Publ. Math. I.H.É.S., 68:1 (1988), pp. 99–114.
- [BT] R. BOTT AND C. TAUBES, *On the self-linking of knots*, J. Math. Phys., 35 (1994), pp. 5247–5287.
- [BH] D. BURGHELEA AND S. HALLER, *On the topology and analysis of a closed one form I*, Monogr. Enseign. Math., 38 (2001), pp. 133–175.
- [Ce] J. CERF, *La stratification naturelle des espaces de fonctions différentiables réelles et le théorème de la pseudo-isotopie*, Publ. Math. I.H.É.S., 39 (1970), pp. 5–173.
- [Ch] J. CHEEGER, *Analytic torsion and the heat equation*, Ann. of Math., 109 (1979), pp. 259–300.
- [Fuk1] K. FUKAYA, *Morse homotopy, A^∞ -category and Floer homologies*, in Proceedings of GARC Workshop on Geometry and Topology, ed. H. J. Kim, Seoul National University, Korea, 1993.
- [Fuk2] K. FUKAYA, *Morse Homotopy and Chern–Simons Perturbation Theory*, Comm. Math. Phys., 181 (1996), pp. 37–90.
- [FO] K. FUKAYA AND Y-G. OH, *Zero-loop open strings in the cotangent bundle and Morse homotopy*, Asian J. Math., 1:1 (1997), pp. 96–180.
- [FM] W. FULTON AND R. MACPHERSON, *A compactification of configuration spaces*, Ann. of Math., 139 (1994), pp. 183–225.
- [Fut] M. FUTAKI, Master thesis, Univ. of Tokyo.
- [GMM] E. GUADAGNINI, M. MARTELLINI, AND M. MINTCHEV, *Perturbative aspects of the Chern–Simons field theory*, Phys. Lett. B, 227 (1989), pp. 111–117.
- [HW] A. HATCHER AND J. WAGONER, *Pseudo-isotopies of compact manifolds*, Astérisque, No. 6. Société Mathématique de France, Paris, 1973. i+275 pp.
- [Hu] M. HUTCHINGS, *Reidemeister torsion in generalized Morse theory*, Forum Math., 14 (2002), pp. 209–244.
- [Ig1] K. IGUSA, *The space of framed functions*, Trans. Amer. Math. Soc., 301:2 (1987), pp. 431–477.
- [Ig2] K. IGUSA, *The stability theorem for smooth pseudoisotopies*, K-Theory, 2 (1988), pp. 1–355.
- [KM] R. KIRBY AND P. MELVIN, *Canonical framings for 3-manifolds*, Proceedings of 6th Gökova Geometry-Topology Conference, Turkish J. Math., 23:1 (1999), pp. 89–115.

- [Ko] M. KONTSEVICH, *Feynman diagrams and low-dimensional topology*, First European Congress of Mathematics, Vol. II (Paris, 1992), Progr. Math., 120 (Birkhauser, Basel, 1994), pp. 97–121.
- [KT] G. KUPERBERG AND D. THURSTON, *Perturbative 3-manifold invariants by cut-and-paste topology*, preprint, arXiv:math/9912167.
- [Lau] F. LAUDENBACH, *Homologie de Morse dans la perspective de l'homologie de Floer*, Minicours dans le cadre de la rencontre GIRAGA XIII, Yaoundé, Septembre 2010.
- [LMO] T. T. Q. LE, J. MURAKAMI, AND T. OHTSUKI, *On a universal perturbative invariant of 3-manifolds*, Topology, 37:3 (1998), pp. 539–574.
- [Les1] C. LESCOP, *On the Kontsevich–Kuperberg–Thurston construction of a configuration-space invariant for rational homology 3-spheres*, math.GT/0411088, Prépublication de l'Institut Fourier, 655 (2004).
- [Les2] C. LESCOP, *Splitting formulae for the Kontsevich–Kuperberg–Thurston invariant of rational homology 3-spheres*, math.GT/0411431.
- [Les3] C. LESCOP, *A formula for the Theta invariant from Heegaard diagrams*, Geom. Topol., 19 (2015), pp. 1205–1248.
- [Mil1] J. MILNOR, *Spin structures on manifolds*, L'Enseign. Math., 9 (1963), pp. 198–203.
- [Mi2] J. MILNOR, *Lectures on the h-cobordism theorem*, Princeton Univ. Press, 1965.
- [Mü] W. MÜLLER, *Analytic torsion and R-torsion on Riemannian manifolds*, Adv. in Math., 28 (1978), pp. 233–305.
- [No] S. NOVIKOV, *Multivalued functions and functionals. An analogue of the Morse theory*. (Russian) Dokl. Akad. Nauk SSSR, 260:1 (1981), pp. 31–35. English translation: Soviet Math. Dokl., 24:2 (1981), pp. 222–226 (1982).
- [Oh] T. OHTSUKI, *Finite type invariants of integral homology 3-spheres*, J. Knot Theory Ramifications, 5 (1996), pp. 101–115.
- [Pa] A. PAJITNOV, *Circle-valued Morse Theory*, de Gruyter Studies in Mathematics 32, Walter de Gruyter, Berlin, 2006.
- [Pe] M. PEIXOTO, *On an approximation theorem of Kupka and Smale*, J. Diff. Eq., 3 (1967), pp. 214–227.
- [Sh] T. SHIMIZU, *An invariant of rational homology 3-spheres via vector fields*, Algebr. Geom. Topol., 16 (2016), pp. 3073–3101.
- [Sm] S. SMALE, *An Infinite Dimensional Version of Sard's Theorem*, Amer. J. Math., 87:4 (1965), pp. 861–866.
- [Wa] T. WATANABE, *On Kontsevich's characteristic classes for higher dimensional sphere bundles. II. Higher classes*, J. Topol., 2:3 (2009), pp. 624–660.
- [Wa1] T. WATANABE, *Higher order generalization of Fukaya's Morse homotopy invariant of 3-manifolds I. Invariants of homology 3-spheres*, arXiv:1202.5754v5.
- [Wa2] T. WATANABE, *Higher order generalization of Fukaya's Morse homotopy invariant of 3-manifolds II. Invariants of 3-manifolds with $b_1 = 1$* , arXiv:1605.05620.
- [Wa3] T. WATANABE, *Morse theory and Lescop's equivariant propagator for 3-manifolds with $b_1 = 1$ fibered over S^1* , arXiv:1403.8030.
- [Wa4] T. WATANABE, *An invariant of fiberwise Morse functions on surface bundle over S^1 by counting graphs*, arXiv:1503.08735.
- [Wa5] T. WATANABE, *Finite type invariants of nullhomologous knots in 3-manifolds fibered over S^1 by counting graphs*, arXiv:1505.01697.
- [We] K. WEHRHEIM, *Smooth structures on Morse trajectory spaces, featuring finite ends and associative gluing*, Geom. Topol. Monogr., 18 (2012) pp. 369–450.
- [Wi1] E. WITTEN, *Supersymmetry and Morse theory*, J. Diff. Geom., 17:4 (1982), pp. 661–692 (1983).
- [Wi2] E. WITTEN, *Quantum field theory and the Jones polynomial*, Comm. Math. Phys., 121:3 (1989), pp. 351–399.
- [Wi3] E. WITTEN, *Chern-Simons gauge theory as a string theory*, The Floer memorial volume, pp. 637–678, Progr. Math., 133, Birkhäuser, Basel, 1995.