

The sharp quantitative Euclidean concentration inequality

ALESSIO FIGALLI^{*}, FRANCESCO MAGGI[†], AND CONNOR MOONEY[‡]

The Euclidean concentration inequality states that, among sets with fixed volume, balls have r -neighborhoods of minimal volume for every $r > 0$. On an arbitrary set, the deviation of this volume growth from that of a ball is shown to control the square of the volume of the symmetric difference between the set and a ball. This estimate is sharp and includes, as a special case, the sharp quantitative isoperimetric inequality proved in [FMP08].

1. Introduction

A sharp stability theory for the Euclidean isoperimetric inequality has been established in recent years in several papers [Fug89, Hal92, FMP08, Mag08, FMP10, CL12, FJ14], and has found applications to classical capillarity theory [FM11, MM16], Gamow’s model for atomic nuclei [KM13, KM14], Ohta-Kawasaki model for diblock copolymers [CS13, GMS13, GMS14], cavitation in nonlinear elasticity [HS13], and slow motion for the Allen-Cahn equation [MR16]. Depending on the application, a sharp stability theory not only conveys better estimates, but it may actually be crucial to conclude anything at all.

The goal of this paper is obtaining a sharp stability result for the Euclidean concentration inequality (i.e., among all sets, balls minimize the volume-growth of their r -neighborhoods). As in the case of the Euclidean isoperimetric inequality, obtaining a sharp stability theory for Euclidean concentration is very interesting from the geometric viewpoint. In addition to this, a strong motivation comes from physical applications. Indeed, the Euclidean concentration inequality is crucial in characterizing equality cases for the physically ubiquitous Riesz rearrangement inequality (see e.g. [LL01, Theorem 3.9]) on radially symmetric strictly decreasing kernels.

^{*}A. Figalli was supported by NSF Grants DMS-1262411 and DMS-1361122.

[†]F. Maggi was supported by NSF Grants DMS-1265910 and DMS-1361122.

[‡]C. Mooney was supported by NSF Grant DMS-1501152.

The need for a quantitative version of the Euclidean concentration inequality in the study of the Gates-Penrose-Lebowitz free energy functional arising in Statistical Mechanics [LP66, GP69] was pointed out in [CCE⁺09]. Recent progress has been achieved in [CM17], where a non-sharp quantitative version of Euclidean concentration is obtained (see below for more details), and where its application to a quantitative understanding of equality cases in Riesz rearrangement inequality is also discussed. The argument used in [CM17], however, is not precise enough to provide a *sharp* stability result, which is the objective of our paper. As a second example of physical applications, a quantitative understanding of the Riesz rearrangement inequality for the Coulomb energy arises in the study of dynamical stability of gaseous stars, and was recently addressed, again in non-sharp form, in [BC15].

On the geometric side, we note that the Euclidean concentration inequality corresponds to the particular case of the Brunn-Minkowski inequality where one of the two sets is a ball. Obtaining a *sharp* stability theory for the Brunn-Minkowski inequality on generic sets is a largely open problem. Despite several contributions by many authors [FMP10, FMP09, Chr12, FJ15, FJ17, CM17] the only case that is completely settled is when both sets are convex. The particular case of the Euclidean concentration inequality, beside being soundly motivated by physical applications, is still already very challenging from the mathematical viewpoint. Indeed, as explained in more detail below, the various methods developed for obtaining the sharp Euclidean isoperimetric inequality (symmetrization techniques, mass transportation, selection principles via regularity theory) cannot be employed for Euclidean concentration. Hence, we shall need to introduce several new geometric ideas specific to this nonlocal setting, and to combine them with various auxiliary results, such as Federer's Steiner-type formula for sets of positive reach and the strong version of the sharp quantitative isoperimetric inequality [FJ14].

We now introduce in detail our problem. Given two sets $E, F \subset \mathbb{R}^n$, the *Brunn-Minkowski inequality* states that

$$(1) \quad |E + F|^{1/n} \geq |E|^{1/n} + |F|^{1/n},$$

with equality if and only if both sets are convex, and one is a dilated translation of the other. Here $|E|$ is the (outer) Lebesgue measure of $E \subset \mathbb{R}^n$, while $E + F = \{x + y : x \in E, y \in F\}$ is the Minkowski sum of E and F . When $F = B_r = \{x \in \mathbb{R}^n : |x| < r\}$ for some $r > 0$, then

$$E + B_r = I_r(E) := \{x \in \mathbb{R}^n : \text{dist}(x, E) < r\}$$

is the r -neighborhood of E and (1) reduces to the *Euclidean concentration inequality*

$$(2) \quad |I_r(E)| \geq |I_r(B_{r_E})|, \quad \forall r > 0,$$

where

$$r_E = \left(\frac{|E|}{|B_1|} \right)^{1/n} = \text{radius of a ball of volume } |E|.$$

It is well-known that inequality (2) is a non-local generalization of the classical *Euclidean isoperimetric inequality*: the latter states that, for any set E , its distributional perimeter $P(E)$ is larger than the one of the ball B_{r_E} , namely

$$(3) \quad P(E) \geq P(B_{r_E}).$$

The isoperimetric inequality (3) can be deduced from (2) as follows: if E is a smooth bounded set then, using (2),

$$P(E) = \lim_{r \rightarrow 0^+} \frac{|I_r(E)| - |E|}{r} \geq \lim_{r \rightarrow 0^+} \frac{|I_r(B_{r_E})| - |E|}{r} = P(B_{r_E}).$$

Then, once (3) has been obtained on smooth set, the general case follows by approximation.

We also mention (although we shall not investigate this here) that the Gaussian counterpart of (2) plays a very important role in Probability theory, see [Led96].

It is natural to ask whether the optimal geometric configurations are stable under small perturbations of equality in (1). This is the stability problem for the Brunn-Minkowski inequality, which can be more precisely formulated by introducing the following quantities. Given two sets $E, F \subset \mathbb{R}^n$ we define the *Brunn-Minkowski deficit* $\delta(E, F)$ of E and F by

$$\delta(E, F) := \max \left\{ \frac{|E|}{|F|}, \frac{|F|}{|E|} \right\}^{1/n} \left(\frac{|E + F|^{1/n}}{|E|^{1/n} + |F|^{1/n}} - 1 \right).$$

This deficit provides a natural measure of the deviation from equality in (1) which is invariant by scaling both E and F by a same factor. Simple examples in dimension $n = 1$ show that the best control on the geometry of E and F provided by $\delta(E, F)$ consists in a bound on the volume of the symmetric difference between E and (a suitable translated and scaled copy

of) the convex envelope $\text{co}(F)$ of F (see for instance [FJ15]). We are thus led to introduce the *relative asymmetry of E with respect to F* by setting

$$\alpha(E, F) := \inf \left\{ \frac{|E \Delta (x + \lambda \text{co}(F))|}{|E|} : x \in \mathbb{R}^n \right\}$$

where $\lambda = (|E|/|\text{co}(F)|)^{1/n}$. Observe that $\alpha(E, F)$ is invariant under (possibly different) dilations of E and F . In the case of the Euclidean concentration inequality we set $F = B_r$ for some $r > 0$, and use

$$(4) \quad \delta_r(E) := \delta(E, B_r) = \max \left\{ \frac{r}{r_E}, \frac{r_E}{r} \right\} \left[\left(\frac{|I_r(E)|}{|I_r(B_{r_E})|} \right)^{1/n} - 1 \right], \quad r > 0,$$

$$(5) \quad \alpha(E) := \alpha(E, B_r) = \inf \left\{ \frac{|E \Delta B_{r_E}(x)|}{|B_{r_E}|} : x \in \mathbb{R}^n \right\}, \quad B_s(x) := x + B_s.$$

We recall that $\alpha(E)$ is usually called the *Fraenkel asymmetry of E* . We now state our main theorem.

Theorem 1.1. *For every $n \geq 2$ there exists a constant $C(n)$ such that*

$$(6) \quad \alpha(E)^2 \leq C(n) \delta_r(E), \quad \forall r > 0,$$

whenever E is a measurable set with $0 < |E| < \infty$; more explicitly, there always exists $x \in \mathbb{R}^n$ such that

$$|I_r(E)| \geq |I_r(B_{r_E})| \left\{ 1 + c(n) \min \left\{ \frac{r}{r_E}, \frac{r_E}{r} \right\} \left(\frac{|E \Delta B_{r_E}(x)|}{|E|} \right)^2 \right\},$$

for some positive constant $c(n)$.

Remark 1.2. The decay rate of $\alpha(E)$ in terms of $\delta_r(E)$ is optimal. Take for example an ellipse which is a small deformation of B_1 given by

$$E_\epsilon := \text{diag} \left(1 + \epsilon, \frac{1}{1 + \epsilon}, 1, \dots, 1 \right) B_1.$$

Then $\alpha(E_\epsilon)$ is order ϵ , and one computes that

$$|E_\epsilon + B_r| = |B_{1+r}| \left(1 + O(\epsilon^2) \frac{r}{(1+r)^2} \right),$$

giving $\delta_r(E_\epsilon) = O(\epsilon^2)$.

Remark 1.3. When $n = 1$ (6) holds with $\alpha(E)$ in place of $\alpha(E)^2$, see [CM17, Theorem 1.1] or [FJ17, Theorem 1.1].

Theorem 1.1 is closely related to the sharp quantitative isoperimetric inequality from [FMP08]

$$(7) \quad \delta_{\text{iso}}(G) \geq c(n) \alpha(G)^2 \quad \text{if } 0 < |G| < \infty,$$

where

$$\delta_{\text{iso}}(G) := \frac{P(G)}{n|B_1|^{1/n}|G|^{(n-1)/n}} - 1.$$

This result is used in the proof of (6), which in turns implies (7) in the limit $r \rightarrow 0^+$. However, the proof of Theorem 1.1 requires entirely new ideas with respect to the ones developed so far in the study of (7). Indeed, the original proof of (7) in [FMP08] uses symmetrization techniques and an induction on dimension argument, based on slicing, that it is unlikely to yield the sharp exponent and the independence from r in the final estimate (compare also with [FJ15, FJ17]). The mass transportation approach adopted in [FMP10] requires a regularization step which replaces a generic set with small δ_{iso} by a nicer set on which the trace-Poincaré inequality holds. While, in our case, it is possible to regularize a set with small δ_r above a scale r (and indeed this idea is used in the proof of Theorem 1.1), it is unclear to us how to perform a full regularization below the scale r . Finally, the penalization technique introduced in [CL12] is based on the regularity theory for local almost-minimizers of the perimeter functional, and there is no analogous theory in this context.

In addition to extending the sharp quantitative isoperimetric inequality, Theorem 1.1 marks a definite progress in the important open problem of proving a sharp quantitative stability result for the Brunn-Minkowski inequality (1) on arbitrary sets. We recall that, in the case that both E and F in (1) are convex, the optimal stability result

$$(8) \quad \alpha(E, F)^2 \leq C(n) \delta(E, F)$$

was established, by two different mass transportation arguments, in [FMP09, FMP10]. Then, in [CM17, Theorem 1.1], exploiting (7), the authors prove that if E is arbitrary and F is convex then

$$(9) \quad \alpha(E, F)^4 \leq C(n) \max \left\{ 1, \frac{|F|}{|E|} \right\}^{(4n+2)/n} \delta(E, F).$$

In the general case when E and F are arbitrary sets, the best results to date are contained in [FJ15] and [FJ17], where $\alpha(E, F)^2$ is replaced by $\alpha(E, F)^{\eta(n)}$ for $\eta(n)$ explicit. We note that this result is nontrivial even in

dimension 1, where the proof uses additive combinatorics. Using a delicate combination of measure theory and affine geometry, the authors are then able to conclude by induction on dimension. There are currently no examples that suggest the exponent should depend on dimension, and we conjecture that, even on arbitrary sets, the optimal exponent for $\alpha(E, F)$ should be 2.

Theorem 1.1 gives a positive answer to this challenging conjecture when $F = B_r$ and E is arbitrary. Notice also that Theorem 1.1 improves the case $F = B_r$ of (9) in two directions, in the sense that $\alpha(E)^4$ is replaced by the sharp $\alpha(E)^2$, and $C(n) \max\{1, |F|/|E|\}^{(4n+2)/n}$ is replaced by $C(n)$.

We now describe the proof of Theorem 1.1. The starting point, as in [CM17], is the idea of using the coarea formula to show that

$$(10) \quad \delta_r(E) \text{ is equal to a certain average of } \gamma_E(s) := P(E + B_s) - P(B_{1+s})$$

over the interval $0 < s < r$. Observe that

$$\gamma_E(s) \geq c(n) |E + B_s|^{(n-1)/n} \delta_{\text{iso}}(E + B_s)$$

thanks to (2). When $\delta_{\text{iso}}(E + B_s)$ is comparable to $\delta_{\text{iso}}(E)$ for a substantial set of radii $s \in (0, r)$, then (7) would allow us to conclude $\delta_r(E) \geq c(n) \alpha(E)^2$. The difficulty, however, is that $\delta_{\text{iso}}(E + B_s)$ may decrease very rapidly for s close to 0, for example if E has lots of small “holes”, so that $\delta_{\text{iso}}(E + B_s)$ becomes negligible with respect to $\delta_{\text{iso}}(E)$. This problem is addressed in [CM17] by an argument which is not precise enough to obtain a quadratic decay rate in the final estimate.

The first key idea that we exploit to overcome this difficulty is introducing a suitable regularization procedure which is compatible with a reduction argument on $\delta_r(E)$ and $\alpha(E)$. More precisely, we introduce the *r-envelope* $\text{co}_r(E)$ of a bounded set E

$$\text{co}_r(E) := \bigcap \left\{ B_r(x)^c : B_r(x) \subset E^c \right\},$$

where, given a set A , we use the notation $A^c := \mathbb{R}^n \setminus A$. From the geometric point of view, it is convenient to think of $\text{co}_r(E)$ as the set obtained by sliding balls of radius r from the exterior of E until they touch E , and filling in the holes of size r or smaller that remain. This construction regularizes the boundary of E at scale r , while not changing the parallel surface at distance r from E (see Figure 1).

This intuition can be made quantitative, in the sense that $\text{co}_r(E)$ always satisfies an exterior ball condition of radius r (Lemma 2.2) and has a

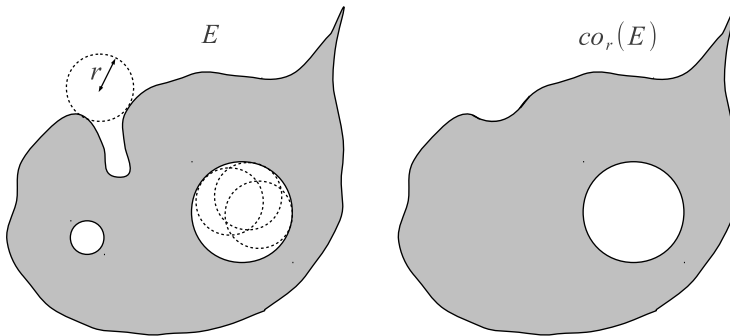

Figure 1: Taking the r -envelope $\text{co}_r(E)$ regularizes the boundary at scale r , without changing the sumset $E + B_r$.

universal perimeter upper bound in each ball of radius s comparable to r (see Lemma 2.4). Moreover, since $E + B_r = \text{co}_r(E) + B_r$, then we easily see that, up to excluding some trivial situations, one always has

$$\alpha(E) \leq C(n) \alpha(\text{co}_r(E)), \quad \delta_r(\text{co}_r(E)) \leq C(n) \delta_r(E),$$

see Proposition 2.3. Hence, in the proof of Theorem 1.1, one can assume that $E = \text{co}_r(E)$. We call such sets r -convex.

The reduction to r -convex sets is particularly effective when r is large with respect to r_E . A first remark is that if r/r_E is large enough and $\delta_r(E) \leq 1$, then E has bounded diameter (in terms of n), after dilating so that $r_E = 1$. This is in sharp contrast with the situation met in the quantitative study of the isoperimetric inequality, where long spikes of small volume and perimeter are of course compatible with the smallness of the isoperimetric deficit δ_{iso} . The r -convexity can then be used jointly with John's lemma to show that if $E \subset B_{R(n)}$, then $B_{r(n)} \subset E$ for some positive dimensional constant $r(n)$. Starting from these properties we can actually check that ∂E is a radial Lipschitz graph with respect to the origin, and that it has positive reach 1. This last property means that every point at distance at most 1 from E has a unique projection on E . By a classical result of Federer, see Theorem 4.2 below, it follows that $P(E + B_s)$ is a polynomial of degree at most $(n - 1)$ for $s \in [0, 1]$. In particular, $\gamma_E(s)$ is a non-negative polynomial of degree at most $(n - 1)$ for $s \in [0, 1]$, so that

$$|I_1(E)| - |I_1(B_1)| = \int_0^1 \gamma_E(s) ds \geq c(n) \gamma_E(0)$$

by a compactness argument (see Lemma 4.3). Combining this bound with the fact that $\gamma_E(0)$ controls $\delta_{\text{iso}}(E)$, (7), and the Brunn-Minkowski inequality, we are able to complete the proof in the regime when r/r_E is large.

We complement the above argument with a different reasoning, which is effective when r/r_E is bounded from above, but actually degenerates as r/r_E becomes larger. The key tool here is the strong quantitative version of the isoperimetric inequality from [FJ14], whose statement is now briefly recalled. Let us set

$$(11) \quad \beta(G)^2 := \inf \left\{ \frac{1}{|G|^{(n-1)/n}} \int_{\partial^* G} \left| \nu_G(y) - \frac{y-x}{|y-x|} \right|^2 d\mathcal{H}_y^{n-1} : x \in \mathbb{R}^n \right\},$$

$$(12) \quad \beta^*(G)^2 := \inf \left\{ \left(\frac{|G \Delta B_{r_G}(x)|}{|G|} \right)^2 + \frac{1}{|G|^{(n-1)/n}} \int_{\partial^* G} \left| \nu_G(y) - \frac{y-x}{|y-x|} \right|^2 d\mathcal{H}_y^{n-1} : x \in \mathbb{R}^n \right\},$$

where ν_G and $\partial^* G$ denote, respectively, the (measure theoretic) outer unit normal and the reduced boundary of G (if G is an open sets with C^1 -boundary, ν_G is standard notion of outer unit normal to G , and $\partial^* G$ agrees with the topological boundary of G). The quantity $\beta(G)$ measures the L^2 -oscillation of ν_G with respect to that of a ball, and in [FJ14] it is proved that

$$(13) \quad C(n) \delta_{\text{iso}}(G) \geq \beta^*(G)^2, \quad 0 < |G| < \infty.$$

Clearly $\alpha(G) \leq \beta^*(G)$, so (13) implies (7). Moreover, as shown in [FJ14, Proposition 1.2], the quantities $\beta(G)$ and $\beta^*(G)$ are actually equivalent:

$$(14) \quad \beta(G) \leq \beta^*(G) \leq C(n) \beta(G).$$

Our argument (based on (13)) is then the following. By combining a precise form of (10) with (13) we deduce that, for some $s < r$, we have

$$C(n, r/r_E) \delta_r(E) \geq \beta(E + B_s)^2 (|E + B_s|/|E|)^{(n-1)/n},$$

where $C(n, r/r_E)$ is a constant that degenerates for r/r_E large. We now exploit the r -convexity property to apply the area formula between the surfaces ∂E and $\partial(E + B_s)$ and compare $\beta(E + B_s)^2 (|E + B_s|/|E|)^{(n-1)/n}$ with $\beta^2(E)$, and thus with $\alpha(E)^2$, which concludes the proof of Theorem 1.1.

The paper is organized as follows. In section 2 we introduce the notion of r -envelope, show some key properties of r -convex sets, and reduce the proof of Theorem 1.1 to this last class of sets. In section 3 we present the argument

based on the strong form of the quantitative isoperimetric inequality, while in section 4 we address the regime when r/r_E is large.

2. Reduction to r -convex sets

In this section we introduce a geometric regularization procedure for subsets of \mathbb{R}^n which can be effectively used to reduce the class of sets considered in Theorem 1.1. We recall the notation $B_r(x) = \{y \in \mathbb{R}^n : |y - x| < r\}$ for the ball of center $x \in \mathbb{R}^n$ and radius $r > 0$ (with $B_r := B_r(0)$) and $E^c = \mathbb{R}^n \setminus E$ for the complement of $E \subset \mathbb{R}^n$.

We begin with the following definitions.

Definition 2.1. Let $E \subset \mathbb{R}^n$ and $r > 0$.

- (i) E satisfies the *exterior ball condition of radius r* if, for all $y \in \partial E$, there exists some ball $B_r(x) \subset E^c$ such that $y \in \partial B_r(x)$.
- (ii) the *r -envelope of E* is the set $\text{co}_r(E)$ defined by

$$\text{co}_r(E) = \left(\bigcup \{B_r(x) : B_r(x) \subset E^c\} \right)^c = \bigcap \{B_r(x)^c : E \subset B_r(x)^c\}.$$

We say that E is *r -convex* if $E = \text{co}_r(E)$.

Notice that E is convex if and only if it satisfies the exterior ball condition of radius r for every $r > 0$. Similarly E is convex if and only if $E = \text{co}_r(E)$ for every $r > 0$.

In Lemma 2.2 we collect some useful properties of $\text{co}_r(E)$, which are then exploited in Proposition 2.3 to reduce the proof of Theorem 1.1 to the case of r -convex sets. Then, in Lemma 2.4 we prove a uniform upper perimeter estimate for r -envelopes which will play an important role in the proof of Theorem 1.1.

Lemma 2.2. *If $E \subset \mathbb{R}^n$ is bounded and $r > 0$, then:*

- (i) $E \subset \text{co}_r(E)$;
- (ii) $\text{co}_r(E)$ is compact;
- (iii) $B_r(x) \subset E^c$ if and only if $B_r(x) \subset \text{co}_r(E)^c$;
- (iv) $E + B_r = \text{co}_r(E) + B_r$;
- (v) $\text{co}_r(E)$ satisfies the exterior ball condition of radius r .

Proof. The first three conclusions are immediate.

If $x \in \text{co}_r(E) + B_r$, then there exists $y \in \text{co}_r(E)$ such that $y \in B_r(x)$; in particular $B_r(x) \cap \text{co}_r(E) \neq \emptyset$, hence $B_r(x) \cap E \neq \emptyset$ by (iii), and thus $x \in E + B_r$, which proves (iv).

Finally, given $x \in \partial(\text{co}_r(E))$, let $x_j \rightarrow x$ with $x_j \in \text{co}_r(E)^c$, so that there exists y_j with $E \subset B_r(y_j)^c$ and $x_j \notin B_r(y_j)^c$. Since $|x_j - y_j| < r$ and $x_j \rightarrow x$,

up to a subsequence we can find $y \in \mathbb{R}^n$ such that $y_j \rightarrow y$ with $|x - y| \leq r$. On the other hand, since $E \subset B_r(y_j)^c$, it follows by (iii) that $B_r(y_j) \subset \text{co}_r(E)^c$, thus $B_r(y) \subset \text{co}_r(E)^c$. As $x \in \text{co}_r(E)$, this implies that $|x - y| \geq r$. In conclusion $|x - y| = r$ and $B_r(y) \subset \text{co}_r(E)^c$, so (v) is proved. \square

We now address the reduction to r -convex sets. Let us recall the following elementary property of the Fraenkel asymmetry:

$$(15) \quad \left| |E| \alpha(E) - |F| \alpha(F) \right| \leq |E \Delta F|, \quad 0 < |E| |F| < \infty,$$

see e.g. [CM17, Lemma 2.2].

Proposition 2.3. *Let E be a bounded measurable set and $r > 0$. There exists a dimensional constant $C(n)$ such that either:*

- (a) $C(n) \delta_r(E) \geq \alpha(E)^2$, or
- (b) we have

$$(16) \quad \alpha(E) \leq C(n) \alpha(\text{co}_r(E)), \quad \delta_r(\text{co}_r(E)) \leq C(n) \delta_r(E).$$

Proof. Without loss of generality we can assume that $|E| = |B_1|$, so that $r_E = 1$. For a suitable constant $b(n) > 0$, we split the argument depending on whether $|\text{co}_r(E) \setminus E| \geq b(n) \alpha(E)$ or not.

If $|\text{co}_r(E) \setminus E| \geq b(n) \alpha(E)$ then, since $\alpha(E) < 2$ and $|E| = |B_1|$, we have

$$|\text{co}_r(E)|^{1/n} \geq (|B_1| + b(n) \alpha(E))^{1/n} \geq |B_1|^{1/n} + c(n) b(n) \alpha(E).$$

Thus, applying Lemma 2.2-(iv) and the Brunn-Minkowski inequality we get

$$\begin{aligned} \delta_r(E) &= \max \left\{ r, \frac{1}{r} \right\} \left(\frac{|E + B_r|^{1/n}}{(1+r)|B_1|^{1/n}} - 1 \right) \\ &= \max \left\{ r, \frac{1}{r} \right\} \left(\frac{|\text{co}_r(E) + B_r|^{1/n}}{|\text{co}_r(E)|^{1/n} + r|B_1|^{1/n}} \frac{|\text{co}_r(E)|^{1/n} + r|B_1|^{1/n}}{(1+r)|B_1|^{1/n}} - 1 \right) \\ &\geq c(n) \max \left\{ r, \frac{1}{r} \right\} \frac{b(n) \alpha(E)}{1+r} \geq c(n) \alpha(E) \geq c(n) \alpha(E)^2, \end{aligned}$$

where in the last inequality we have used again $\alpha(E) < 2$. This proves the validity of (a).

We are thus left to show that if $|\text{co}_r(E) \setminus E| < b(n) \alpha(E)$, then (16) holds. By exploiting (15) with $F = \text{co}_r(E)$ and assuming $b(n)$ small enough, then $|\text{co}_r(E) \setminus E| < b(n) \alpha(E)$ gives $\alpha(\text{co}_r(E)) \geq c(n) \alpha(E)$. At the same time, using again that $|\text{co}_r(E) \setminus E| < b(n) \alpha(E) \leq 2b(n)$ we find that the volumes of $|E|$ and $|\text{co}_r(E)|$ are comparable, therefore

$$\max \left\{ \frac{|\text{co}_r(E)|}{|B_r|}, \frac{|B_r|}{|\text{co}_r(E)|} \right\} \leq C(n) \max \left\{ \frac{|E|}{|B_r|}, \frac{|B_r|}{|E|} \right\}.$$

In addition, it follows by Lemma 2.2-(iv) and the trivial inequality $|E| \leq |\text{co}_r(E)|$ that

$$\frac{|\text{co}_r(E) + B_r|^{1/n}}{|\text{co}_r(E)|^{1/n} + |B_r|^{1/n}} \leq \frac{|E + B_r|^{1/n}}{|E|^{1/n} + |B_r|^{1/n}}.$$

This shows that $\delta_r(\text{co}_r(E)) \leq C(n) \delta_r(E)$, and (16) is proved. □

Intuitively, r -convex sets are nice up to scale r . In this direction, the following lemma provides a uniform perimeter bound. Here and in the sequel we use the notation $P(F; B_s(x))$ to denote the perimeter of a set F inside the ball $B_s(x)$. In particular, if F is a smooth set, $P(F; B_s(x)) = \mathcal{H}^{n-1}(\partial F \cap B_s(x))$.

Lemma 2.4. *If E is a bounded set and $r > 0$, then $\text{co}_r(E)$ has finite perimeter and*

$$(17) \quad P(\text{co}_r(E); B_s(x)) \leq \frac{C(n)}{1 - (s/r)} s^{n-1}, \quad \forall s < r, x \in \text{co}_r(E).$$

Proof. The open set $\text{co}_r(E)^c$ is the union of the open balls $B_r(x)$ such that $B_r(x) \subset E^c$. Thus there exist an at most countable set I such that

$$\text{co}_r(E)^c = \bigcup_{i \in I} B_r(x_i) \quad B_r(x_i) \subset E^c \quad x_j \neq x_i \text{ if } i \neq j.$$

Let I_N be an increasing sequence of finite subsets of I with $\#I_N = N$. We fix N and for $i \in I_N$ we define the spherical region

$$\Sigma_i := \partial B_r(x_i) \cap \bigcap_{j \in I_N, j \neq i} B_r(x_j)^c$$

and the intersection of $B_r(x_i)$ with the cone of vertex x_i over Σ_i ,

$$K_i := B_r(x_i) \cap \{x_i + t(x - x_i) : x \in \Sigma_i, 0 \leq t < 1\}$$

(see Figure 2).

Since $x_i \neq x_j$ for each $i \neq j$, we see that

$$(18) \quad \mathcal{H}^{n-1}(\Sigma_i \cap \Sigma_j) = |K_i \cap K_j| = 0 \quad \forall i \neq j.$$

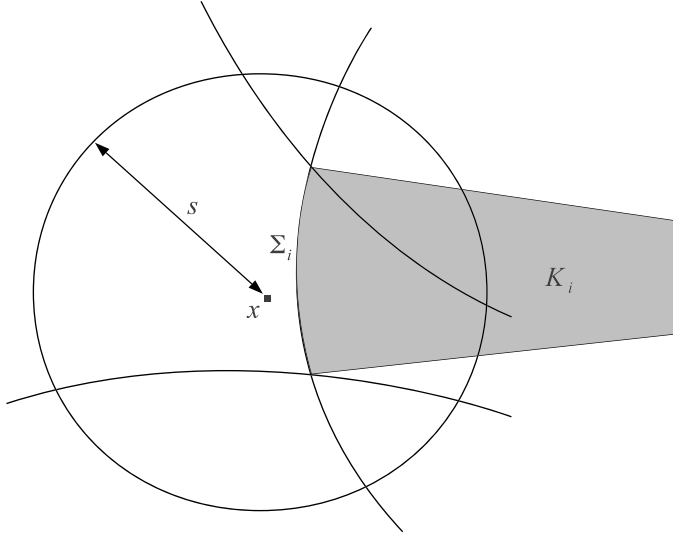

Figure 2: The area of Σ_i in $B_s(x)$ is controlled by the area of $\partial B_s(x)$ in K_i and the volume of $B_s(x)$ in K_i .

Let $x \in \text{co}_r(E)$ and $s < r$, so that $|y - x_i| > |x - x_i| - s \geq r - s$ for each i and $y \in B_s(x)$. By applying the divergence theorem to the vector field $v_i(y) = (y - x_i)/|y - x_i|$ over $K_i \cap B_s(x)$, we find

$$\int_{K_i \cap B_s(x)} \frac{n-1}{|y - x_i|} dy = \mathcal{H}^{n-1}(\Sigma_i \cap B_s(x)) - \int_{K_i \cap \partial B_s(x)} \frac{y - x_i}{|y - x_i|} \cdot \frac{y - x}{|y - x|} d\mathcal{H}^{n-1}(y),$$

and thus

$$\mathcal{H}^{n-1}(\Sigma_i \cap B_s(x)) \leq \mathcal{H}^{n-1}(K_i \cap \partial B_s(x)) + (n-1) \frac{|K_i \cap B_s(x)|}{r-s}.$$

Hence, it follows by (18) that

$$\begin{aligned} \mathcal{H}^{n-1}\left(B_s(x) \cap \bigcup_{i \in I_N} \Sigma_i\right) &\leq \mathcal{H}^{n-1}(\partial B_s(x)) + (n-1) |B_1| \frac{s^n}{r-s} \\ (19) \qquad \qquad \qquad &\leq \frac{C(n)}{1 - (s/r)} s^{n-1}. \end{aligned}$$

To conclude the proof, fix $R > 1$ such that $\text{co}_r(E) + B_r \subset B_R$, and set

$$(20) \quad F_N := \overline{B_R} \cap \bigcap_{i \in I_N} B_r(x_i)^c.$$

Notice that F_N is a decreasing family of compact sets of finite perimeter, with

$$\text{co}_r(E) = \bigcap_{N \in \mathbb{N}} F_N \quad \lim_{N \rightarrow \infty} |\text{co}_r(E) \Delta F_N| = 0 \quad B_R \cap \partial^* F_N = B_R \cap \bigcup_{i \in I_N} \Sigma_i,$$

(the last identity modulo \mathcal{H}^{n-1} -negligible sets). Since $B_s(x) \subset\subset B_R$ we conclude from (19) that

$$P(F_N; B_s(x)) \leq \frac{C(n)}{1 - (s/r)} s^{n-1},$$

and then deduce (17) by lower semicontinuity of the distributional perimeter. □

Remark 2.5. Let E be such that $E = \text{co}_r(E)$ for some $r > 0$, and let F_N be the compact sets defined in the previous proof. Noticing that

$$E + \overline{B_s} = \bigcap_{N \in \mathbb{N}} (F_N + \overline{B_s}), \quad \forall s > 0,$$

and since $|E + \overline{B_s}| = |E + B_s|$ we conclude that, for every $s > 0$, $|F_N + B_s| \rightarrow |E + B_s|$ as $N \rightarrow \infty$. In particular, taking $s = r$ and recalling (15) and $|F_N \Delta E| \rightarrow 0$ we conclude that

$$(21) \quad \alpha(E) = \lim_{N \rightarrow \infty} \alpha(F_N) \quad \delta_r(E) = \lim_{N \rightarrow \infty} \delta_r(F_N).$$

3. A stability estimate which degenerates for r large

In this section we present an argument based on the strong quantitative isoperimetric inequality (13) which leads to a stability estimate which degenerates for r large. We recall that

$$r_E = \left(\frac{|E|}{|B_1|} \right)^{1/n}.$$

Theorem 3.1. *If E is a bounded r -convex set, then*

$$C(n) \max \left\{ 1, \left(\frac{r}{r_E} \right)^{n-1} \right\} \delta_r(E) \geq \alpha(E)^2.$$

The following lemma is a preliminary step to the proof of Theorem 3.1. Recall that

$$\gamma_E(s) = P(E + B_s) - P(B_{r_E+s}),$$

is non-negative for every $s > 0$ thanks to the Brunn-Minkowski and isoperimetric inequalities.

Lemma 3.2. *If E is compact and $\delta_r(E) < 1$, then $E + B_s$ has finite perimeter for a.e. $s > 0$ and*

$$(22) \quad \delta_r(E) \geq c(n) \frac{\max\{r_E/r, r/r_E\}}{(r_E + r)^n} \int_0^r \gamma_E(s) ds,$$

with $\gamma_E(s) \geq c(n) |E + B_s|^{(n-1)/n} \delta_{\text{iso}}(E + B_s)$ for every $s \geq 0$.

Proof. By [CM17, Lemma 2.1] we have $|E + B_t| = |E| + \int_0^t P(E + B_s) ds$ for every $t > 0$, hence $E + B_s$ has finite perimeter for a.e. $s > 0$ and

$$|E + B_r| - |B_{r_E+r}| = \int_0^r \gamma_E(s) ds.$$

Dividing by $|B_{r_E+r}|$ and manipulating the expression we have

$$\delta_r(E) = \max \left\{ \frac{r}{r_E}, \frac{r_E}{r} \right\} \left(\left(1 + \frac{1}{|B_{r_E+r}|} \int_0^r \gamma_E(s) ds \right)^{1/n} - 1 \right).$$

Since $\delta_r(E) < 1$ we deduce that

$$\frac{1}{|B_{r_E+r}|} \int_0^r \gamma_E(s) ds \leq 2^n - 1,$$

hence the result follows from the concavity inequality

$$(1+t)^{1/n} > 1 + 2^{-n} t, \quad \forall 0 < t < 2^n - 1. \quad \square$$

Proof of Theorem 3.1. If E is r -convex, then λE is λr -convex for every $\lambda > 0$. Since $\delta_r(E) = \delta_{r/r_E}(E/r_E)$ where $|E/r_E| = |B_1|$, up to replacing E by E/r_E it is enough to show that if $r > 0$ and E is an r -convex set with $|E| = |B_1|$, then

$$(23) \quad C(n) \max\{1, r^{n-1}\} \delta_r(E) \geq \alpha(E)^2.$$

Since $\alpha(E) < 2$, without loss of generality we can assume that

$$\delta_r(E) < \frac{\varepsilon(n)}{\max\{1, r^{n-1}\}} \leq 1$$

for a constant $\varepsilon(n)$ to be suitably chosen in the proof. Since E is bounded and r -convex we have $E = \text{co}_r(E)$ and thus we can consider the sets F_N introduced in the proof of Lemma 2.4 and in Remark 2.5 (see (20)). We have $|F_N| \geq |B_1|$ and, for N large enough,

$$(24) \quad \delta_r(F_N) < \frac{\varepsilon(n)}{\max\{1, r^{n-1}\}} \leq 1.$$

Defining

$$\gamma_N(s) := P(G_s) - P(B_{r_{F_N}+s}), \quad G_s := F_N + B_s, \quad s \in (0, r),$$

it follows by Lemma 3.2 applied to F_N that

$$\begin{aligned} C(n) \max\{r, r_{F_N}\}^{n-2} \delta_r(F_N) &\geq \frac{1}{r} \int_0^r \gamma_N(s) ds, \\ \gamma_N(s) &\geq c(n) \delta_{\text{iso}}(G_s) |G_s|^{(n-1)/n} \quad \forall s \in (0, r). \end{aligned}$$

Since $r_{F_N} \rightarrow r_E = 1$, there exists $s < \varepsilon(n) \min\{1, r\}$ such that

$$(25) \quad \begin{aligned} C(n) \max\{1, r^{n-1}\} \delta_r(F_N) &\geq \gamma_N(s) \geq c(n) \delta_{\text{iso}}(G_s) |G_s|^{(n-1)/n} \\ &\geq c(n) \beta^*(G_s)^2 |G_s|^{(n-1)/n}, \end{aligned}$$

where in the last inequality we have used (13). Up to a translation we assume that

$$\beta^*(G_s)^2 = \left(\frac{|G_s \Delta B_{r_{G_s}}|}{|G_s|} \right)^2 + \frac{1}{|G_s|^{(n-1)/n}} \int_{\partial^* G_s} \left| \nu_{G_s}(y) - \frac{y}{|y|} \right|^2 d\mathcal{H}_y^{n-1}.$$

Let us notice that

$$\partial^* F_N = \bigcup_{i \in I_N} (B_R \cap \Sigma_i) \cup \left(\bigcap_{i \in I_N} \overline{B_r(x_i)}^c \cap \partial B_R \right)$$

with

$$\nu_{F_N}(x) = -\frac{x - x_i}{|x - x_i|}, \quad \mathcal{H}^{n-1}\text{-a.e. on } \partial^* F_N \cap \Sigma_i,$$

$$\nu_{F_N}(x) = \frac{x}{|x|}, \quad \mathcal{H}^{n-1}\text{-a.e. on } \partial^* F_N \cap \partial B_R.$$

Recalling that $R > 1$, we see that map $T : \partial^* F_N \rightarrow \partial^* G_s$ defined as

$$T(x) := x + s \nu_{F_N}(x) \quad \forall x \in \partial^* F_N,$$

is injective and satisfies

$$\begin{aligned} \nu_{G_s}(T(x)) &= \nu_{F_N}(x), \\ \frac{|T(x) - T(y)|}{|x - y|} &\geq \begin{cases} 1 - C s/r & \forall x, y \in B_R \cap \partial^* F_N \\ 1 - C s/R & \forall x, y \in \partial B_R \cap \partial^* F_N. \end{cases} \end{aligned}$$

Since $s \leq \varepsilon(n) \min\{1, r\}$ we thus find that the tangential Jacobian $JT : \partial^* F_N \rightarrow \mathbb{R}$ of T along $\partial^* F_N$ satisfies $JT \geq 1/2$, and thus by the area formula

$$\begin{aligned} \int_{\partial^* G_s} \left| \nu_{G_s}(y) - \frac{y}{|y|} \right|^2 d\mathcal{H}_y^{n-1} &\geq \int_{\partial^* F_N} \left| \nu_{G_s}(T(x)) - \frac{T(x)}{|T(x)|} \right|^2 JT(x) d\mathcal{H}_x^{n-1} \\ (26) \quad &\geq \frac{1}{2} \int_{\partial^* F_N} \left| \nu_{F_N}(x) - \frac{T(x)}{|T(x)|} \right|^2 d\mathcal{H}_x^{n-1}. \end{aligned}$$

Now it is easily seen that if $|e| = 1$ and $|z| > 2s > 0$, then

$$\left| \frac{z}{|z|} - \frac{z + s e}{|z + s e|} \right| \leq C(n) \min \left\{ \left| \frac{z}{|z|} - e \right|, \left| \frac{z}{|z|} + e \right| \right\}.$$

Hence, by taking $z = x + s \nu_{F_N}(x) = T(x)$ and $e = -\nu_{F_N}(x)$, we find that

$$(27) \quad \left| \frac{x}{|x|} - \frac{T(x)}{|T(x)|} \right| \leq C(n) \left| \frac{T(x)}{|T(x)|} - \nu_{F_N}(x) \right| \quad \forall x \in \partial^* F_N, |x| > 3s.$$

We now split the argument in two cases.

Case one: We assume that $|x| > 3s$ for \mathcal{H}^{n-1} -a.e. $x \in \partial^* F_N$ and for infinitely many values of N . In this case, combining (27) with (25) and (26) we obtain

$$\begin{aligned} C(n) \max\{1, r^{n-1}\} \delta_r(F_N) &\geq \int_{\partial^* F_N} \left| \nu_{F_N}(x) - \frac{x}{|x|} \right|^2 d\mathcal{H}_x^{n-1} \\ &\geq |F_N|^{(n-1)/n} \beta(F_N)^2 \end{aligned}$$

that is, by (14),

$$C(n) \max\{1, r^{n-1}\} \delta_r(F_N) \geq |F_N|^{(n-1)/n} \alpha(F_N)^2.$$

Since $|F_N| \rightarrow |E| = |B_1|$ as $N \rightarrow \infty$, we conclude by (21) that

$$C(n) \max\{1, r^{n-1}\} \delta_r(E) \geq |B_1|^{(n-1)/n} \alpha(E)^2 \geq c(n) \alpha(E)^2.$$

This completes the discussion of case one.

Case two: We assume that, for every N large enough,

$$(28) \quad \mathcal{H}^{n-1}(\partial^* F_N \cap B_{3s}) > 0.$$

Combining (25), (26), and (27), one finds

$$(29) \quad \int_{\partial^* F_N} \left| \nu_{F_N}(x) - \frac{x}{|x|} \right|^2 d\mathcal{H}_x^{n-1} \leq 2 \mathcal{H}^{n-1}(\partial^* F_N \cap B_{3s}) + C(n) \max\{1, r^{n-1}\} \delta_r(F_N).$$

Also, it follows by (28) that there exists $x \in F_N \cap B_{3s}$. Thus, since $F_N = \text{co}_r(F_N)$, it follows by (17) that, provided $\varepsilon(n)$ is small enough,

$$(30) \quad \mathcal{H}^{n-1}(\partial^* F_N \cap B_{3s}) \leq \mathcal{H}^{n-1}(\partial^* F_N \cap B_{6s}(x)) \leq C(n) s^{n-1}.$$

We now claim that (28) implies

$$(31) \quad \int_{\partial^* G_s} \left| \nu_{G_s}(x) - \frac{x}{|x|} \right|^2 d\mathcal{H}_x^{n-1} \geq c(n) s^{n-1}.$$

Notice that, if we can prove (31), then combining that estimate with (25), (30), and (29), we get

$$\int_{\partial^* F_N} \left| \nu_{F_N}(x) - \frac{x}{|x|} \right|^2 d\mathcal{H}_x^{n-1} \leq C(n) \max\{1, r^{n-1}\} \delta_r(F_N),$$

which allows us to conclude as in case one. Hence, to conclude the proof is enough to prove (31).

To this aim we first notice that, setting for the sake of brevity $\sigma := r_{G_s}$ (so that $\sigma \geq r_{F_N} \geq r_E = 1$), then (24) and (25) imply that

$$(32) \quad |B_\sigma \setminus G_s| \leq |G_s \Delta B_\sigma| \leq \sqrt{\varepsilon(n)} |B_\sigma|.$$

Next we notice that there exists a ball $B_s(z_0)$ such that

$$(33) \quad B_s(z_0) \subset (G_s)^c \cap B_{6s}.$$

Indeed, (28) implies the existence of $x_0 \in \partial^* F_N \subset \partial F_N$ with $|x_0| < 3s$. Since F_N is r -convex there exists $B_r(y_0) \subset (F_N)^c$ such that $|x_0 - y_0| = r$. Since

$B_{r-s}(y_0) \subset (G_s)^c$, $|y_0 - x_0| = r$, and $|x_0| < 3s$, we can easily find z_0 such that (33) holds.

Now let $\tau \in (0, 1)$ be a parameter to be fixed later on and let $e = z_0/|z_0|$ if $z_0 \neq 0$, or $e = e_1$ if $z_0 = 0$. Let us consider the spherical cap

$$\Sigma_\tau := \left\{ x \in \partial B_s(z_0) : x = z_0 + s v \text{ with } v \cdot e = \cos \alpha \text{ for some } |\alpha| < \tau \right\}.$$

Given $x \in \Sigma_\tau$ let

$$t(x) := \inf \left\{ t > 0 : z_0 + t \frac{x - z_0}{s} \in \partial^* G_s \right\},$$

so that $t(x) \in (s, \infty]$, and let

$$\Sigma_\tau^* := \left\{ x \in \Sigma_\tau : t(x) < \sigma - 6s \right\}.$$

In this way the map $\psi : \Sigma_\tau^* \rightarrow \mathbb{R}^n$ defined as

$$\psi(x) := z_0 + \frac{t(x)}{s}(x - z_0) \quad x \in \Sigma_\tau^*$$

satisfies $\psi(\Sigma_\tau^*) \subset B_\sigma \cap \partial^* G_s$ with

$$(34) \quad \nu_{G_s}(\psi(x)) \cdot \frac{x - z_0}{s} \leq 0, \quad \forall x \in \Sigma_\tau^*,$$

and a Taylor's expansion gives

$$(35) \quad \left| \frac{\psi(x)}{|\psi(x)|} - \frac{x - z_0}{s} \right| \leq C\tau \quad \forall x \in \Sigma_\tau^*.$$

Hence, if $y \in \Sigma_\tau^*$, then by (34) and (35)

$$\frac{1}{2} \left| \nu_{G_s}(y) - \frac{y}{|y|} \right|^2 = 1 - \nu_{G_s}(\psi(x)) \cdot \frac{\psi(x)}{|\psi(x)|} \geq 1 - C\tau \geq \frac{1}{2}$$

(see Figure 3), therefore

$$(36) \quad \int_{\partial^* G_s} \left| \nu_{G_s}(y) - \frac{y}{|y|} \right|^2 d\mathcal{H}_y^{n-1} \geq \mathcal{H}^{n-1}(\Sigma_\tau^*).$$

On the other hand we have

$$Z := \left\{ z_0 + t \frac{x - z_0}{s} : x \in \Sigma_\tau \setminus \Sigma_\tau^*, t \in (0, S - 6s) \right\} \subset B_\sigma \setminus G_s,$$

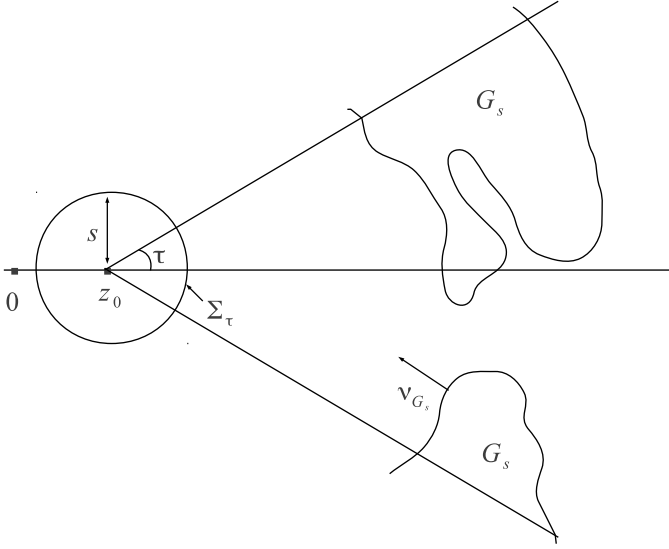

Figure 3: On the part of ∂G_s that is accessible to rays from z_0 through Σ_τ , the normal ν_{G_s} is far from $x/|x|$.

so it follows by (32) that

$$\begin{aligned} C(n) \sqrt{\varepsilon(n)} \sigma^n &\geq |Z| = \int_0^{\sigma-6s} \rho^{n-1} \mathcal{H}^{n-1} \left(\frac{\Sigma_\tau \setminus \Sigma_\tau^*}{s} \right) d\rho \\ &= \frac{(\sigma-6s)^n}{n s^{n-1}} \mathcal{H}^{n-1}(\Sigma_\tau \setminus \Sigma_\tau^*) \end{aligned}$$

that is $\mathcal{H}^{n-1}(\Sigma_\tau \setminus \Sigma_\tau^*) \leq C(n) \sqrt{\varepsilon(n)} s^{n-1}$. Since $\mathcal{H}^{n-1}(\Sigma_\tau) \geq c(n, \tau) s^{n-1}$, choosing ε small enough we conclude that $\mathcal{H}^{n-1}(\Sigma_\tau^*) \geq c(n) s^{n-1}$, that combined with (36) concludes the proof of (31). \square

4. A stability estimate for r/r_E large

We now address the case when r/r_E is large.

Theorem 4.1. *There exists $C(n)$ such that if E is a measurable set with $0 < |E| < \infty$ and $r \geq C(n) r_E$, then*

$$C(n) \delta_r(E) \geq \alpha(E)^2.$$

The argument exploits the notion of sets of positive reach and the corresponding *Steiner's formula*. Let us recall that if $r > 0$ and E is a closed subset of \mathbb{R}^n , then E has *positive reach* r if for every x with $\text{dist}(x, E) < r$ there exists a unique closest point to x in E . This property allows one to exploit the area formula to deduce that $P(E+B_s)$ is a polynomial for $s \in [0, r]$.

Theorem 4.2 (Federer [Fed59]). *If E has positive reach r , then $s \mapsto P(E+B_s)$ is a polynomial of degree at most $n-1$ on the interval $[0, r]$.*

A second tool used in our argument is the following elementary lemma.

Lemma 4.3. *If p is a non-negative polynomial on $[0, 1]$, then*

$$\int_0^1 p(x) dx \geq cP(0)$$

where c is a positive constant depending only on the degree of p .

Proof. Let us assume without loss of generality that $p(0) = 1$. Let $\alpha \geq 0$ be the largest slope such that $\alpha x \leq p(x)$ for every $x \in [0, 1]$. Since $p(x) - \alpha x$ and $p(x)$ are both non-negative polynomials on $[0, 1]$ with same value at $x = 0$, we can replace $p(x)$ with $p(x) - \alpha x$. In doing so we gain the information that our polynomial has either a zero at $x = 1$, or a zero of order at least two at $x = a$ for some $a \in (0, 1)$. In particular, either $p(x) = q(x)(1-x)$ or $p(x) = q(x)(x-a)^2$, where q is a non-negative polynomial in $[0, 1]$ with $q(0) \geq 1$ and degree strictly less than the degree of p . By iterating the procedure we reduce ourselves to the case where, for some $0 \leq k \leq \deg(p)/2$,

$$p(x) = c(1-x)^{n-2k} \prod_{i=1}^k (x-a_i)^2,$$

where $\{a_i\}_{i=1}^k \subset (0, 1)$ and $c \geq 1$ (since $p(0) \geq 1$). In particular,

$$\int_0^1 p(x) dx \geq \min_{(b_1, \dots, b_n) \in [0, 1]^n} f(b_1, \dots, b_n),$$

where

$$f(b_1, \dots, b_n) := \int_0^1 \prod_{i=1}^n |x - b_i| dx.$$

Clearly f is continuous and strictly positive on $[0, 1]^n$. By compactness,

$$\min_{(b_1, \dots, b_n) \in [0, 1]^n} f(b_1, \dots, b_n) > c(n),$$

and the proof is complete. \square

We are now ready to prove Theorem 4.1.

Proof of Theorem 4.1. We can directly assume that E is r -convex with

$$|E| = |B_1|, \quad \delta_r(E) < 1, \quad r \geq C(n) \geq 1.$$

We claim that

$$(37) \quad E \text{ has positive reach } 1.$$

This claim allows one to quickly conclude the proof. Indeed, it follows by Theorem 4.2 that, for $s < 1$, the perimeter deficit $\gamma_E(s)$ is a nonnegative polynomial of degree at most $n - 1$, so we can apply Lemma 4.3 to conclude that

$$|E + B_1| - |B_2| = \int_0^1 \gamma_E(s) ds \geq c(n) \gamma_E(0).$$

In particular, applying (7) we obtain

$$|E + B_1| \geq |B_2| + c(n) \alpha(E)^2 \geq |B_{2+c(n)\alpha(E)^2}|,$$

since $\alpha(E) \leq 2$. Since $r > 1$ by assumption, it follows from the Brunn-Minkowski inequality that

$$|E + B_r| \geq |B_{1+r+c(n)\alpha(E)^2}|$$

hence

$$\delta_r(E) \geq c(n) \frac{r}{1+r} \alpha(E)^2 \geq c(n) \alpha(E)^2,$$

which is the desired inequality. Hence, we are left to prove (37). Before doing so, we first make some comments about the argument we just showed.

Remark 4.4. The proof above works for any set E with reach $\min\{1, r\}$, for any $r > 0$. In particular, it proves the main theorem in the case that E is convex. In the case when r is small one has that

$$C(n) \delta_r(E) \geq \frac{1}{r} \int_0^r \gamma_E(s) ds.$$

Since the integrand is a positive polynomial for $s < r$, the result follows immediately from Lemma 4.3 and inequality (7).

Note however that, given a bounded set E , for small r we cannot affirm that $\text{co}_r(E)$ has reach r . Take for example B_2 minus two small balls of radius $2r$ whose centers are at distance $4r - \delta$ with $\delta \ll r$. Then this set coincides with its r -envelope, but has reach that goes to 0 as $\delta \rightarrow 0$.

Remark 4.5. Our technique also gives an alternative proof of sharp stability for Brunn-Minkowski in the case that E and F are both convex. In this case one uses the existence of a Steiner polynomial for a certain weighted perimeter of $E + sF$ (see [BZ80]), and the sharp quantitative anisotropic isoperimetric inequality [FMP10].

We now prove (37). We achieve this in five steps.

Step one: We prove that $\text{diam}(E) \leq R(n)$ for some $R(n)$. Indeed given two points $x, y \in E$, we find

$$|E + B_r| \geq |B_r(x) \cup B_r(y)| \geq |B_r| \min \left\{ 1 + c_0(n) \frac{|x - y|}{r}, 2 \right\}.$$

Since $r \geq 1$ and thus $r/(1+r) \geq 1/2$, we get

$$(38) \quad \begin{aligned} \delta_r(E) &= \max \left\{ r, \frac{1}{r} \right\} \left(\frac{|E + B_r|^{1/n}}{(1+r)|B_1|^{1/n}} - 1 \right) \\ &\geq \frac{1}{2} \left(\min \left\{ r \left(1 + c_0(n) \frac{|x - y|}{r} \right)^{1/n}, 2^{1/n} r \right\} - 1 - r \right). \end{aligned}$$

If the minimum in the right hand side was achieved by $2^{1/n}r$ then we would find $2\delta_r(E) \geq (2^{1/n} - 1)r - 1 \geq 2$ provided $r \geq C(n)$ for $C(n)$ large enough, which is impossible since $\delta_r(E) < 1$. Thus we must have that

$$\left(1 + c_0(n) \frac{|x - y|}{r} \right)^{1/n} \leq 2^{1/n}, \quad \text{that is} \quad c_0(n) \frac{|x - y|}{r} \leq 1.$$

Since $(1+s)^{1/n} \geq 1 + c(n)s$ for every $s \in (0, 1)$, we deduce that

$$r \left(1 + c_0(n) \frac{|x - y|}{r} \right)^{1/n} - 1 - r \geq c(n) |x - y| - 1,$$

hence it follows by (38) that $c(n) |x - y| \leq 1 + 2\delta_r(E) \leq 3$, as desired.

Step two: By step one it follows that, up to a translation, $E \subset B_{R(n)}$. We now prove that (after possibly another translation)

$$B_{r(n)} \subset E$$

for some $r(n) > 0$.

Let $\text{co}(E)$ denote the convex hull of E . By John's lemma there exists an affine transformation $L : \mathbb{R}^n \rightarrow \mathbb{R}^n$ such that

$$B_1 \subset L(\text{co}(E)) \subset B_n.$$

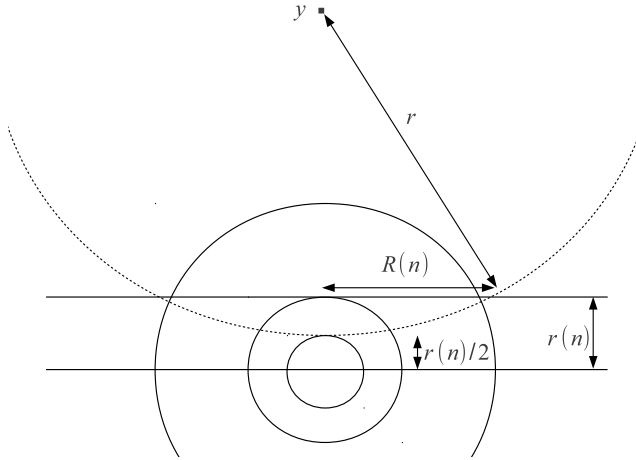

Figure 4: If r is large and an exterior ball $B_r(y)$ intersects $B_{r(n)/2}$, then $B_{r(n)}$ is not in the convex hull of E .

Since $\text{co}(E) \subset B_{R(n)}$ and $|E| = |B_1| \leq |\text{co}(E)|$ we deduce that $\text{Lip } L$, $\text{Lip } L^{-1} \leq C(n)$. In particular, up to a translation, we deduce that

$$B_{r(n)} \subset \text{co}(E)$$

for some $r(n) > 0$. We now claim that if $r \geq C(n)$ for $C(n)$ large enough, then $B_{r(n)/2} \subset E$ too.

Indeed, if not, there exists $x \in E^c \cap B_{r(n)/2}$. Since E is r -convex, this means that $x \in B_r(y)$ for some $B_r(y) \subset E^c$, which implies that (after possibly replacing $R(n)$ by $2R(n)$)

$$(39) \quad E \subset B_{R(n)} \setminus B_r(y), \quad \text{where } |y| \leq r + \frac{r(n)}{2}.$$

Since $r \geq C(n)$ and $|y| \leq r + r(n)/2$, we can pick $C(n)$ large enough with respect to $r(n)$ and $R(n)$ to ensure that

$$B_{R(n)} \setminus B_r(y) \subset \left\{ z \in \mathbb{R}^n : z \cdot \frac{y}{|y|} \leq \frac{2r(n)}{3} \right\}.$$

Recalling (39), this implies that

$$\text{co}(E) \subset \left\{ z \in \mathbb{R}^n : z \cdot \frac{y}{|y|} \leq \frac{2r(n)}{3} \right\},$$

against $B_{r(n)} \subset \text{co}(E)$ (see Figure 4).

Step three: We claim that there exists $\delta(n) \in (0, 1)$ with the following property: for every two-dimensional plane Π through the origin and each $x \in \Pi \cap \partial E$, there exists a disk of radius $\delta(n)r$ contained in $\Pi \cap E^c$ whose boundary contains x .

Indeed, let $B_r(z)$ be an exterior tangent ball to E that touches x . Choose coordinates so that Π is the e_1, e_2 plane. By rotations in Π and then in its orthogonal complement, we may assume that $z = z_1 e_1 + z_n e_n$, with $z_i \geq 0$. Since $B_r(z) \cap B_{r(n)} = \emptyset$ (by Step two) we have

$$z_1^2 + z_n^2 \geq (r + r(n))^2.$$

On the other hand, since $x \in B_{R(n)}$ we know $\partial B_r(z)$ intersects the x_1 axis at some point αe_1 with $r(n) \leq \alpha \leq R(n)$. We thus have

$$(z_1 - \alpha)^2 + z_n^2 = r^2.$$

Combining these we obtain

$$z_1 \geq \frac{2r r(n) + r(n)^2 + \alpha^2}{2\alpha} > \frac{r(n)}{R(n)} r.$$

Note that $B_r(z) \cap \Pi$ is a disc of radius $z_1 - \alpha$ centered on the x_1 axis, and by the above we have

$$z_1 - \alpha \geq r \left(\frac{r(n)}{R(n)} - \frac{R(n)}{r} \right) > \frac{r(n)}{2R(n)} r$$

provided $r > 2R(n)^2/r(n)$, which proves our claim (see Figure 5).

Step four: We show that $\partial E \cap \Pi$ is a radial graph for any two-plane Π through the origin. Indeed, recall that $B_{r(n)} \subset E$. Follow a ray from the origin in Π until the first time it hits ∂E at some point $x \in B_{R(n)}$. By the previous step we know that there is an exterior tangent disc in Π of radius $\delta(n)r$ whose boundary contains x . Using that this disc does not intersect $B_{r(n)} \cap \Pi$ and similar arguments to those in the previous step, one concludes that the radial line segment from x to $\partial B_{R(n)}$ is in E^c if r is sufficiently large, and since $E \subset B_{R(n)}$ the claim is established.

Step five: We finally prove (37). In view of the previous steps we may take r large so that, after a translation, $B_{r(n)} \subset E \subset B_{R(n)}$, and ∂E restricted to any two-plane is a radial graph with external tangent circles of radius 2.

Assume by way of contradiction that E does not have reach 1. Then there is some exterior tangent ball of radius less than 1 touching ∂E at two

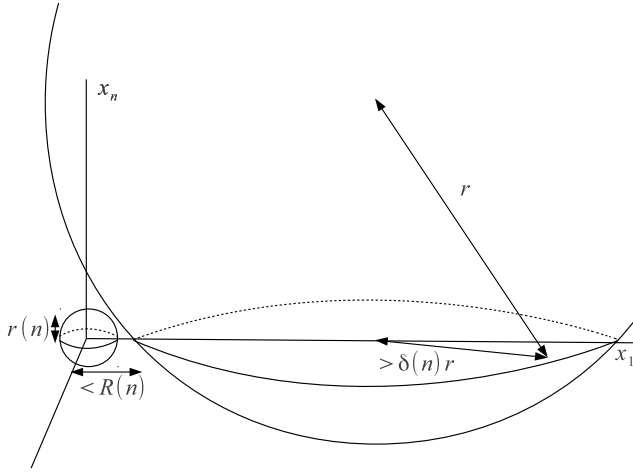

Figure 5: When we restrict to a plane, E has exterior tangent circles of radius comparable to r .

points y_1 and y_2 . Let Π be the two-plane containing y_i and the origin, and choose coordinates so that Π is the e_1, e_2 plane. Then there is an exterior tangent disc of radius less than 1 touching $\partial E \cap \Pi$ at y_1 and y_2 . Denote by $D_t(x)$ the disk in Π of radius t centered at x . Up to a rotation in Π , we can assume that both y_1 and y_2 touch an exterior tangent disc $D_{t_0}(\beta e_1)$, with $t_0 \leq 1$ and $\beta > t_0 + r(n)$ (since $B_{r(n)} \subset E$).

Now, let S be the sector in Π bounded by the rays from the origin through y_i , and let C_s be the radial graph given by the left part of $\partial D_{t_0}((t_0 + s)e_1) \cap S$, for $0 \leq s \leq \beta - t_0$. Note that $C_s \subset E \cap \Pi$ for all s small (since $B_{r(n)} \subset E$). Furthermore, the endpoints of C_s on ∂S are in E for all $0 \leq s < \beta - t_0$ since $\partial E \cap \Pi$ is a radial graph. Since $D_{t_0}(\beta e_1)$ is exterior to $E \cap \Pi$, we can increase s until C_s first touches $\partial E \cap \Pi$ for some $0 < s_0 \leq \beta - t_0$. (In particular, $C_s \subset E \cap \Pi$ for all $0 \leq s < s_0$.) Hence, this proves the existence of a point $y_3 \neq y_1, y_2$ which belongs to $C_{s_0} \cap \partial E$.

Since $y_3 \in \partial E$, we know that there is an exterior tangent disc of radius 2 whose boundary contains y_3 . On the other hand, since $t_0 \leq 1$, any such disc will contain points in C_s for some $s < s_0$, a contradiction that concludes the proof (see Figure 6). \square

Acknowledgments

C. Mooney would like to thank L. Caffarelli for a helpful conversation.

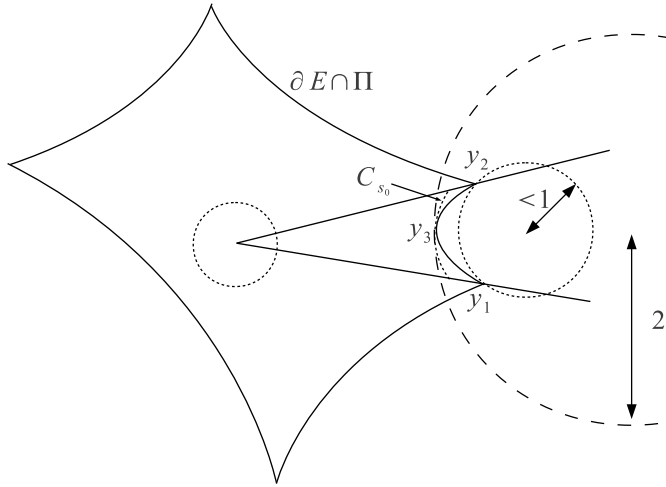

Figure 6: If on some two-plane the radial graph ∂E does not have reach 1, we get a contradiction for r large.

References

- [BC15] A. Burchard and G. R. Chambers. Geometric stability of the Coulomb energy. *Calc. Var. Partial Differential Equations*, 54(3):3241–3250, 2015.
- [BZ80] Y. D. Burago and V. A. Zalgaller. *Geometric Inequalities*. Springer-Verlag, Berlin-Heidelberg-New York-Tokyo, 1980.
- [CCE⁺09] E. A. Carlen, M. C. Carvalho, R. Esposito, J. L. Lebowitz, and R. Marra. Droplet minimizers for the Gates-Lebowitz-Penrose free energy functional. *Nonlinearity*, 22(12):2919–2952, 2009.
- [CM17] E. Carlen and F. Maggi. Stability for the Brunn-Minkowski and Riesz rearrangement inequalities, with applications to Gaussian concentration and finite range non-local isoperimetry. *Canad. J. Math.*, 69(5):1036–1063, 2017.
- [Chr12] M. Christ. Near equality in the Brunn-Minkowski inequality, 2012. arXiv:1207.5062.
- [CL12] M. Cicalese and G. P. Leonardi. A selection principle for the sharp quantitative isoperimetric inequality. *Arch. Rat. Mech. Anal.*, 206(2):617–643, 2012.

- [CS13] M. Cicalese and E. Spadaro. Droplet minimizers of an isoperimetric problem with long-range interactions. *Comm. Pure Appl. Math.*, 66(8):1298–1333, 2013.
- [Fed59] H. Federer. Curvature measures. *Trans. Amer. Math. Soc.*, 93:418–491, 1959.
- [FJ15] A. Figalli and D. Jerison. Quantitative stability for sumsets in \mathbb{R}^n . *J. Eur. Math. Soc.*, 17(5):1079–1106, 2015.
- [FJ17] A. Figalli and D. Jerison. Quantitative stability for the Brunn-Minkowski inequality. *Adv. Math.*, 314:1–47, 2017.
- [FM11] A. Figalli and F. Maggi. On the shape of liquid drops and crystals in the small mass regime. *Arch. Rat. Mech. Anal.*, 201:143–207, 2011.
- [FMP09] A. Figalli, F. Maggi, and A. Pratelli. A refined Brunn-Minkowski inequality for convex sets. *Ann. Inst. H. Poincaré Anal. Non Linéaire*, 26(6):2511–2519, 2009.
- [FMP10] A. Figalli, F. Maggi, and A. Pratelli. A mass transportation approach to quantitative isoperimetric inequalities. *Inv. Math.*, 182(1):167–211, 2010.
- [Fug89] B. Fuglede. Stability in the isoperimetric problem for convex or nearly spherical domains in \mathbb{R}^n . *Trans. Amer. Math. Soc.*, 314:619–638, 1989.
- [FMP08] N. Fusco, F. Maggi, and A. Pratelli. The sharp quantitative isoperimetric inequality. *Ann. Math.*, 168:941–980, 2008.
- [FJ14] N. Fusco and V. Julin. A strong form of the quantitative isoperimetric inequality. *Calc. Var. Partial Differential Equations*, 50(3–4):925–937, 2014.
- [GP69] D. J. Gates and O. Penrose. The van der Waals limit for classical systems. I. A variational principle. *Comm. Math. Phys.*, 15:255–276, 1969.
- [GMS13] D. Goldman, C. B. Muratov, and S. Serfaty. The Γ -limit of the two-dimensional Ohta-Kawasaki energy. I. Droplet density. *Arch. Ration. Mech. Anal.*, 210(2):581–613, 2013.
- [GMS14] D. Goldman, C. B. Muratov, and S. Serfaty. The Γ -limit of the two-dimensional Ohta-Kawasaki energy. Droplet arrangement via

- the renormalized energy. *Arch. Ration. Mech. Anal.*, 212(2):445–501, 2014.
- [Hal92] R. R. Hall. A quantitative isoperimetric inequality in n -dimensional space. *J. Reine Angew. Math.*, 428:161–176, 1992.
- [HS13] D. Henao and S. Serfaty. Energy estimates and cavity interaction for a critical-exponent cavitation model. *Comm. Pure Appl. Math.*, 66(7):1028–1101, 2013.
- [KM13] Hans Knüpfer and Cyrill B. Muratov. On an isoperimetric problem with a competing nonlocal term I: The planar case. *Comm. Pure Appl. Math.*, 66(7):1129–1162, 2013.
- [KM14] Hans Knüpfer and Cyrill B. Muratov. On an isoperimetric problem with a competing nonlocal term II: The general case. *Comm. Pure Appl. Math.*, 67(12):1974–1994, 2014.
- [LP66] J. L. Lebowitz and O. Penrose. Rigorous treatment of the van der Waals-Maxwell theory of the liquid-vapor transition. *J. Mathematical Phys.*, 7:98–113, 1966.
- [Led96] M. Ledoux. Isoperimetry and Gaussian analysis. In *Lectures on probability theory and statistics (Saint-Flour, 1994)*, volume 1648 of *Lecture Notes in Math.*, pages 165–294. Springer, Berlin, 1996.
- [LL01] Elliott H. Lieb and Michael Loss. *Analysis*, volume 14 of *Graduate Studies in Mathematics*. American Mathematical Society, Providence, RI, second edition, 2001.
- [Mag08] F. Maggi. Some methods for studying stability in isoperimetric type problems. *Bull. Amer. Math. Soc.*, 45:367–408, 2008.
- [MM16] F. Maggi and C. Mihaila. On the shape of capillarity droplets in a container. *Calc. Var. Partial Differential Equations*, 55(5):Art. 122, 42, 2016.
- [MR16] R. Murray and M. Rinaldi. Slow motion for the nonlocal Allen-Cahn equation in n dimensions. *Calc. Var. Partial Differential Equations*, 55(6):Art. 147, 33, 2016.

ALESSIO FIGALLI
 ETH ZÜRICH, DEPT. OF MATH.
 RÄMISTRASSE 101
 8092 ZÜRICH
 SWITZERLAND
E-mail address: alessio.figalli@math.ethz.ch

FRANCESCO MAGGI
UT AUSTIN, DEPT. OF MATH., RLM 8.100
2515 SPEEDWAY STOP C1200
AUSTIN, TX 78712
USA

E-mail address: maggi@math.utexas.edu

CONNOR MOONEY
ETH ZÜRICH, DEPT. OF MATH.
RÄMISTRASSE 101
8092 ZÜRICH
SWITZERLAND

E-mail address: connor.mooney@math.ethz.ch

RECEIVED JULY 13, 2017